

Holley®



HOLLEY

S I N C E 1 9 0 3

Performance Catalog



NEW & HOT *Products*



**Aluminum Street
& Truck Avenger
Carburetors - Page 14**



**Commander 950®
Wide Band O2
Upgrade Kit
With Bosch®
Sensor - Page 105**



**Street HP
Carburetors - Page 20**



**Commander 950®
Wide Band O2
Gauge - Page 105**



**HP & Ultra HP
Mechanical Fuel
Pumps - Page 127**



**Holley Carburetor
Installation & Tuning
DVD - Page 170**



**Wedged
Floats - Page 73**



**Holley Brand Metal
Signs - Page 165**



**Ford 4.6L Throttle
Bodies - Page 123**



**Holley Brand
Clocks - Page 166**



**LS2 Throttle
Bodies - Page 123**



**Holley
Apparel - Page 164**

Holley History 2-4

Carburetors 6-95

How to Choose a Carburetor 6-9

Street Performance Carburetors by Type 10-21

Street Performance Carburetors by CFM 22-33

2bbl Street Carburetors. 10-11

Traditional Carburetors 12-13

Street Avenger Carburetors. 14-15

Truck Avenger Carburetors 16-17

Double Pumper® Carburetors 18-19

Street HP Carburetors 20-21

Supercharger Carburetors 34-35

Race Carburetors by Type. 36-47

Race Carburetors by CFM. 48-58

2-bbl Race Carburetors HP Series 36-37

Competition Carburetors. 38-39

HP Carburetors – Model 4150 40-41

Ultra HP Carburetors – Model 4150 42-43

Dominator® HP Carburetors 44-45

Ultra Dominator® HP Carburetors 46-47

Marine Carburetors. 59-63

Model 4160 Carburetor Exploded View 64

Accelerator Pump Hardware 65-66

Adapters & Spacers. 67

Brackets & Linkage 68-70

Solenoids 69-70

Dashpots. 70

Chokes & Fuel Filters 71

Fittings 72

Floats 73

Fuel Bowls, Kits & Parts 74-75

Fuel Line Selection Chart 76-77

Gaskets 78-80

Gaskets - Service Kits 81-84

Gauges 85

Kits & Assortments 86

Metering Jets 87-89

Metering Jets - Air Bleeds. 88

Metering Plates, Blocks & Service Parts 90

Needle & Seat Assemblies 91

Power Valves. 92-93

Vacuum Secondaries. 94-95

Fuel Injection 98-118

Commander 950® Pro Overview 98-99

Commander 950® Engine Management Systems 100

Stealth Ram™ Multi-Point Fuel Injection Systems 101

Commander 950® MPFI Specific 102-103

Commander 950® Systems & Hardware 104

Commander 950® Hardware & MPFI Power Packs 105

MPFI Power Packs. 106

Stealth Ram™ MPFI Power Packs 107

Commander 950® Service Parts. 108-109

Commander 950® 4-bbl Throttle Body Fuel Injection 110-112

Marine Commander 950® 4-bbl Throttle Body Fuel Injection 112

670 CFM Pro-Jection® 113

Marine Pro-Jection® 2-bbl Throttle Body Fuel Injection. 113

Throttle Body Service Parts 114-117

Fuel Rails & Injector Kits. 118

Throttle Bodies 120-123

Direct Replacement Performance Truck TBIs 120

Airfoil Kit. 121

Universal 4-bbl Billet Throttle Bodies 121

High-Flow EFI Throttle Bodies 122-123

Fuel Pumps 126-140

Mechanical Fuel Pumps 126-127

Electric Fuel Pumps. 128-132

Marine Mechanical Fuel Pumps 133

Marine Electric Fuel Pumps. 134

Regulators & Accessories 135-137

VoluMAX® Filters & Accessories 138-140

Electric Fuel Pump Service Kits. 139-140

Intake Manifolds 142-146

Chevrolet Small Block V8 142-143

Chevrolet Big Block V8 144-145

Chrysler Big Block V8 145

Ford Small Block V8 145

Service Parts 146

Cylinder Heads 148-150

Chevrolet Small Block 148

Chevrolet Big Block – Oval Port 149

Ford Small Block 150

SystemAX® 152-156

Overview. 152

Chevrolet Small Block V8 153-154

Ford 5.0L EFI Kits 155

Engine Components 156

Engine Dress-Up 158-160

Merchandising 162-170

Technical Information 171-210

Carburetor Numerical Listing 172-191

Technical Help. 192-210

Part Number Index 211-216

Alphabetical Index 217-222

Emission Codes. 223

Warranty. 224-225

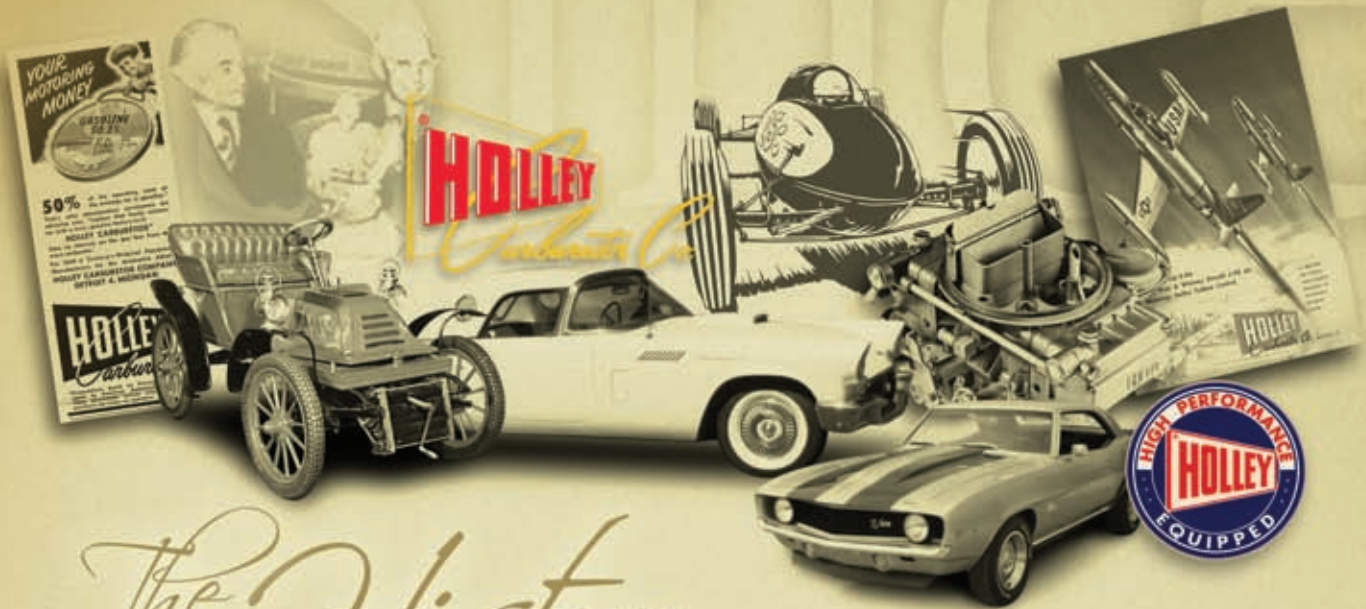

*The History of
Performance...*
...yesterday, today & tomorrow!

Holley has been manufacturing fuel systems of all shapes and sizes since 1903. In fact, over 250,000,000 carburetors have been produced over the years for everything from Henry Ford's original Model A to the baddest factory muscle cars ever to roll out of Detroit. Did you know that Holley supplied over half the carburetors in WWII including not just automobiles, but PT Boats and airplanes? It's true. No company knows fuel systems like Holley. Today, Holley carburetors continue to be a dominant force in high performance and racing, winning more races than all others combined. Holley carbs have powered every NASCAR® SPRINT® Cup Series team and every winning NHRA® Pro Stock team since the 1960s and every weekend still today.

It all began in the late 1800s with two brothers from Bradford, PA, George and Earl Holley - teenage boys who learned how to make patterns and castings so they could build a one cylinder engine. That engine was put onto a three wheeled vehicle that hit an impressive 30 MPH. That led to motorized bicycles, a four wheeled automobile called the Holley Motorette and the birth of the Holley Motor Company. In 1903, at the urging of Henry Ford, the Holley brothers entered the carburetor business and became industry leaders in fuel

system technology. In 2003 Holley was recognized as one of four original suppliers still selling to Ford after 100 years. The company business continued to expand through the World War I and World War II era. It could be said that Holley directly helped win World War II as about half the carburetors used bore the Holley name. Holley fuel systems were on everything from variable venturii carburetors on the DC-3 airplane, Packard powered PT boats to the B-25s used in Jimmy Doolittle's air raid on Tokyo. Following the war Holley concentrated on

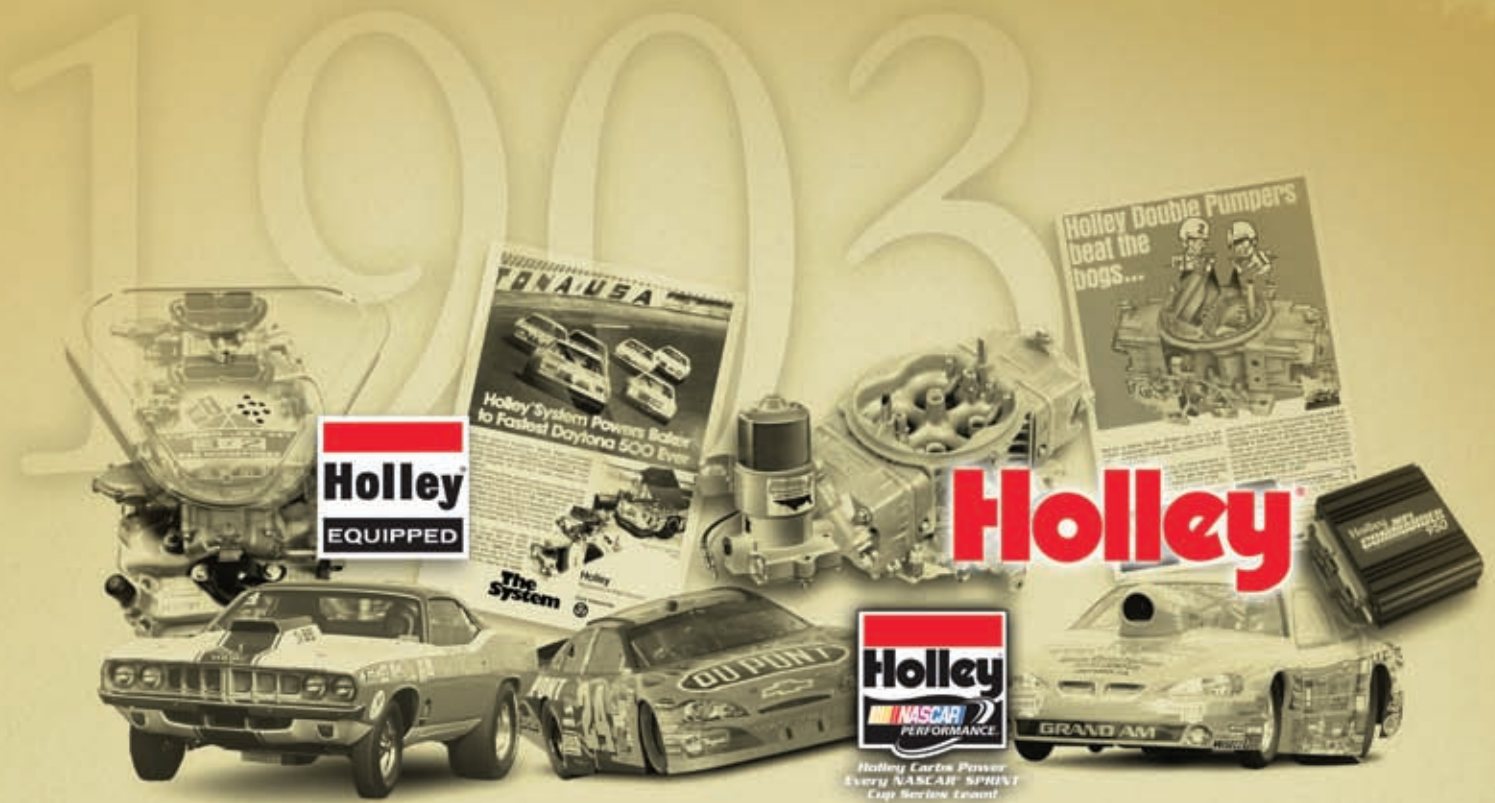

keeping up with the requirements of automobile manufacturers who, in turn, were trying to keep up with the demands of a car-hungry public. Holley also began supplying repair parts to service stations and garages. War scrapped airplane belly tanks were finding their way to the salt flats and carburetors like the famous Holley 94s were powering many of these racers.

The 1950's saw the introduction of the Holley Model 4150 4-barrel on the 1957 T-bird. It was the beginning of the modular Holley 4-barrel as we know it today. It was the first true performance carburetor and became standard equipment on many high performance automobiles.

The 1960's were huge for the hot rod industry, and Holley, as the Model 4150 became original equipment on the baddest factory muscle cars ever to come out of Detroit. It powered cars like the popular Z28 Camaros, Big Block Chevilles, Boss Mustangs and Shelby Cobras to name a few. This era also saw the introduction of the awesome Holley three deuce multi carb set-ups on 427 (Tri Power) Corvettes and 440 (Six Pack) Mopars. If it was a serious car it had to have a Holley. An American icon was also born in the '60s as the Holley Double Pumper® rolled off the line. The world famous Holley Dominator® also made its debut in 1968, developed specifically for NASCAR® racing.

The 1970s saw Holley's continuation of dominance in racing with nearly every factory NHRA® Super Stock/Pro Stock racer running Holley's. That hasn't changed and in fact, Holley carbs have powered more drag racers than all other carbs combined, still today. The early 70's also saw the introduction of the world famous Holley "Blue" electric fuel pump which also became the most dominant fuel pump in drag racing history. It too powers tens-of-thousands of racers and street enthusiasts still today. This era also saw the introduction of Holley aluminum intake manifolds, including the once popular Z-Series developed in conjunction with Zora Arkus-Duntov.

Holley entered the 1980's positioned as the only carburetor manufacturer to offer entire fuel systems from intakes to fuel pumps. Holley continued its dominance in nearly all forms of racing powering all winning NHRA Pro Stock racers and once again all NASCAR® Sprint® Cup Series teams of the day. The '80s also saw Holley's entrance into the fuel injection market where original equipment EFI components and analog Pro-Jection® retrofit fuel injection systems for carbureted cars were introduced.

In the 1990's Holley continued its new product introductions. The wildly popular HP Pro Series race ready carburetors were introduced and have become the standard in racing ever since. The, still popular, SystemeMAX® engine kits were introduced with matched cylinder heads, intakes and cams. The Dominator also evolved in the '90s into the HP Dominator, huge billet electric fuel pumps were introduced, and retrofit EFI kits evolved into digital Pro-Jection 4D and 4Di. At the end of the 1990s Holley acquired several other top brands in their categories including Weiland intakes and superchargers, Flowtech Exhaust, Hooker Headers, Earl's Plumbing and NOS Nitrous Oxide Systems, expanding their offering and securing the title of the Winningest Company in Racing History.

In addition to products from its other brands, so far in the new millennium Holley has introduced the popular Street Avenger, Truck Avenger, Street HP and Ultra HP carburetors as well as billet mechanical fuel pumps. Holley's EFI systems evolved with the Commander 950® ECU and now includes a full line of billet aluminum high flow EFI throttle bodies, multipoint EFI kits and Stealth Ram™ EFI kits. Just recently in 2007, the Holley 3310 carburetor was inducted into the Inaugural Hot Rod Magazine Speed Parts Hall of Fame as one of the top ten influential speed parts of all time. Holley looks forward to continuing its influence on the performance aftermarket for another 100 years. We hope you do to!

From Start to Finish...

...Holley's NASCAR Heritage!

From the early beach racing days all the way up through today, Holley carbs have been powering NASCAR® teams. In fact, Holley carbs have powered every NASCAR Cup team since the 1960's. The world famous Holley Dominator was developed for NASCAR racing in 1968. Model 4150 Holley carbs powered teams through the '80s and early '90s. In 1994 the popular race ready HP Pro Series carbs were developed and soon gained wide acceptance in NASCAR. HP carbs are still the standard, powering every Sprint® Cup, Nationwide® and Craftsman® Truck team each weekend still today. **Holley carbs still continue to prove themselves 500 miles at a time!**



**Powering Every
NASCAR® SPRINT®
Cup Series Team!**

NASCAR® and NASCAR Performance® are registered trademarks of the National Association for Stock Car Auto Racing, Inc.



CARBURETORS

CARBURETORS 6 - 95

How to Choose a Carburetor	6-9	Marine Carburetors	59-63
Street Performance Carburetors by Type	10-21	Model 4160 Carburetor Exploded View	64
Street Performance Carburetors by CFM	22-33	Accelerator Pump Hardware	65-66
2bbl Street Carburetors	10-11	Adapters & Spacers	67
Traditional Carburetors	12-13	Brackets & Linkage	68-70
Street Avenger Carburetors	14-15	Solenoids	69-70
Truck Avenger Carburetors	16-17	Dashpots	70
Double Pumper® Carburetors	18-19	Chokes & Fuel Filters	71
Street HP Carburetors	20-21	Fittings	72
Supercharger Carburetors	34-35	Floats	73
Race Carburetors by Type	36-47	Fuel Bowls, Kits & Parts	74-75
Race Carburetors by CFM	48-58	Fuel Line Selection Chart	76-77
2-bbl Race Carburetors HP Series	36-37	Gaskets	78-80
Competition Carburetors	38-39	Gaskets - Service Kits	81-84
HP Carburetors – Model 4150	40-41	Gauges	85
Ultra HP Carburetors – Model 4150	42-43	Kits & Assortments	86
Dominator® HP Carburetors	44-45	Metering Jets	87-89
Ultra Dominator® HP Carburetors	46-47	Metering Jets - Air Bleeds	88
		Metering Plates, Blocks & Service Parts	90
		Needle & Seat Assemblies	91
		Power Valves	92-93
		Vacuum Secondaries	94-95

Mr. CarbTune's How to Choose a Carburetor

Hi I'm Mr. CarbTune! Choosing a carburetor can be a daunting task. Not anymore! Just following my easy 4 step process below. Or, see my simple selection charts across from each carburetor feature page.

STEP 1. First let's calculate the proper carburetor CFM for your engine. Use this simple formula.

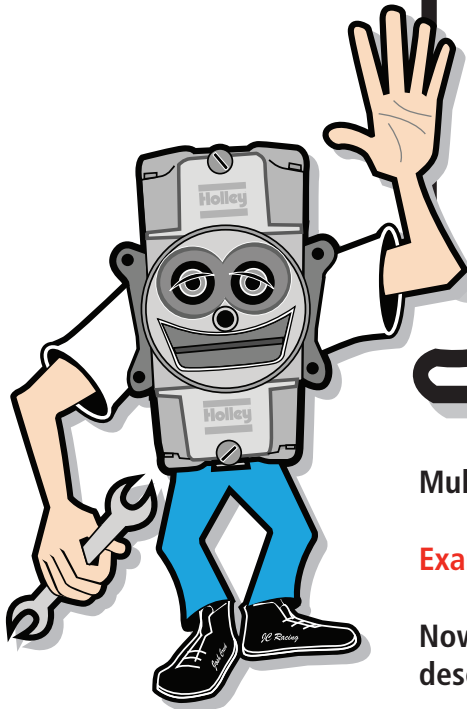

Multiply (Engine CID X Maximum RPM) ÷ 3456

Example: (350 CID X 6,000 RPM) ÷ 3456 = 607.63 CFM

Now determine your engine's volumetric efficiency by the below descriptions.

- Stock engines = 80% volumetric efficiency (.80)
- Mildly modified engines = 85% volumetric efficiency (.85) (performance camshaft, intake, headers & ignition)
- Highly modified engines = 95% volumetric efficiency (.95) (performance camshaft, intake, headers, ignition, aluminum heads/ported iron heads, 11:1 compression or higher)

Now multiply the CFM you first calculated by your volumetric efficiency.

Example: 607.63 CFM X .85 = 516 CFM will supply your engine. If there is no CFM carburetor of that size, simply pick the next size up.

STEP 2.

Next let's determine if you need mechanical or vacuum secondaries.

Most cars will need a carburetor with vacuum secondaries.

If your vehicle does not meet the below requirements, you should use a vacuum secondary carburetor. Most vehicles will use a vacuum secondary carburetor. The secondaries on a vacuum secondary carburetor open as the engine demands more fuel and air. (See page 94 for a detailed explanation of how it works.)

Mechanical secondaries (aka Double Pumpers®) should be limited to use on lighter vehicles. It should be 3,100 lbs or lighter full weight. Full weight includes fuel and driver. If the vehicle meets the above weight requirement and has a manual transmission with a low first gear, plus a 3:73 or lower rear end ratio, you can use a mechanical secondary carburetor. If the manual transmission has a high low gear such as a 2:20 you should have a rear end ratio of 4:56 or lower to use a mechanical secondary carburetor.

If the vehicle has an automatic transmission and meets the 3,100 lb weight requirement, you should have a true minimum stall of 4,000 RPM, a minimum 4:56 rear end ratio for 2 speed transmissions or a minimum of 3:73 rear end ratio for 3 or 4 speed automatics before you should use a mechanical secondary carburetor.

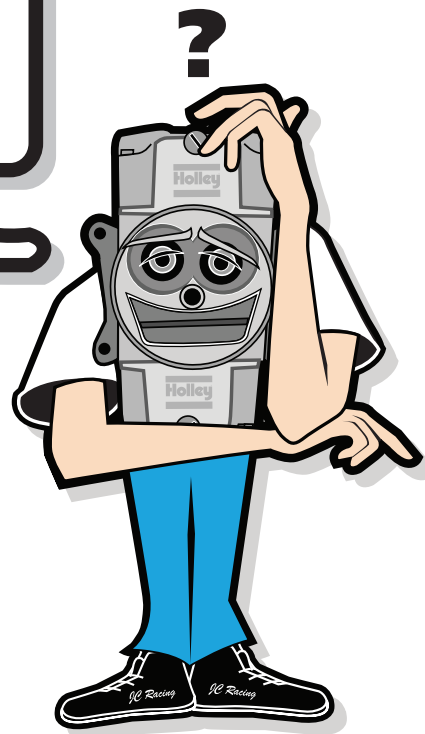

STEP 3.

Now let's pick the type of choke you want.

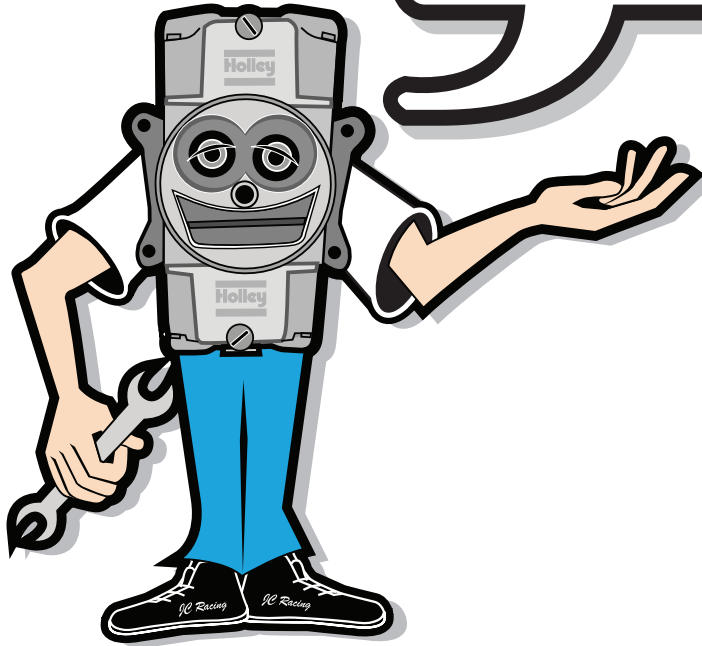
**ELECTRIC CHOKE****MANUAL CHOKE****NO CHOKE**

Electric chokes fully handle the warm up of your engine/carb without your assistance. They operate off a single 12 volt switched power wire from your vehicle.

Manual chokes allow the user to control the warm up of their engine/carb by physically pulling a cable inside the vehicle. This type of choke is generally less expensive than an electric choke.

Carburetors without a choke are typically used in racing and require the operator to warm up the engine with the throttle pedal.

STEP 4.

Now you are ready to use the rest of this catalog to pick the type of carburetor you desire. Shop by CFM or carburetor type!

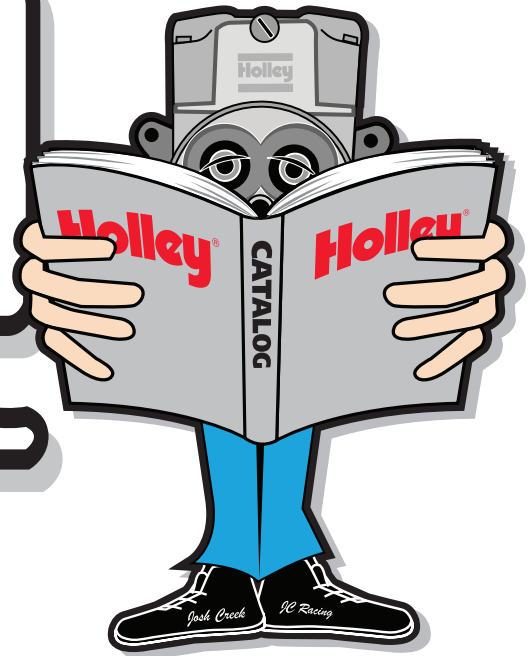

Don't want to use my 4 step process? Try our live **Interactive Carburetor Selector** at **holley.com!** It's easy! Just type in your CID at the top of our homepage to begin!



HOW TO CHOOSE A CARB
STREET CARBURETORS
SUPERCHARGER CARBURETORS
RACE CARBURETORS
MARINE CARBURETORS
CARB SERVICE PARTS & ACCESSORIES
FUEL INJECTION
THROTTLE BODIES
FUEL PUMPS
INTAKE MANIFOLDS
CYLINDER HEADS
SYSTEMAX
ENGINE DRESS-UP
MERCHANDISING
TECHNICAL INFORMATION
INDEX

2-bbl Street Carburetors - Model 2300™

Stock performance replacement for 2-bbl street applications. Also mandated carbs for some oval track racing sanctioning bodies.

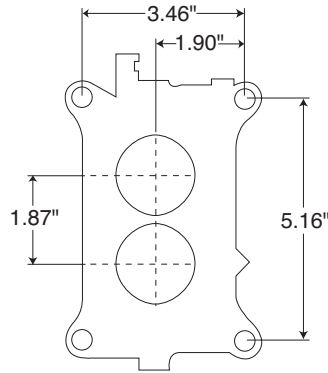

Power Valve Blow-out Protection adds trouble-free operation

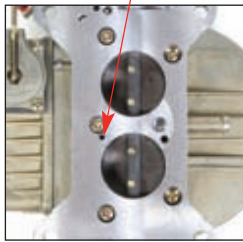

Manual Choke for easy control of engine warm up

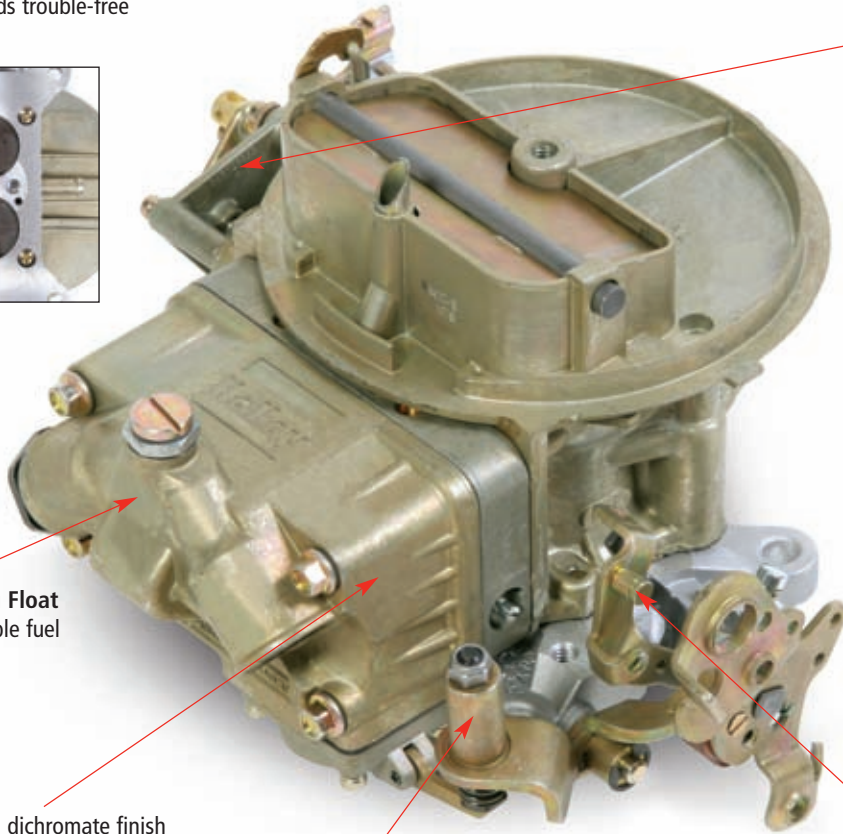

CenterHung Float provides stable fuel level control

100% Wet-Flow Tested And Calibrated to ensure bolt on performance out of the box

Available in dichromate finish for corrosion resistance or shiny finish for good looks

Ford A/T Kickdown for ease of installation on vehicles with C4 & C6 transmission (Ford A/T kickdown, does not work with A.O.D. transmissions)

Factory Set Accelerator Pump provides excellent off-idle performance
350 CFM - 30cc
500 CFM - 50cc

Description	Dichromate	Shiny
350 CFM Two Barrel	Part # 0-7448^(B) ⬢	n/a
500 CFM Two Barrel	Part # 0-4412C^(B) ⬢	Part # 0-4412S^(B) ⬢



See HP Race Ready 2-bbls on page 36

2-bbl Model 2300™ Carburetors

Use this chart to determine CFM sizing for typical Street and Stock Replacement engines used in daily drivers and trucks

Cubic Inches

400	0-4412C 0-4412S	0-4412C 0-4412S	0-4412C 0-4412S	Contact Holley Tech Service for a Recommendation	Contact Holley Tech Service for a Recommendation
375	0-7448	0-4412C 0-4412S	0-4412C 0-4412S	0-4412C 0-4412S	Contact Holley Tech Service for a Recommendation
350	0-7448	0-7448	0-4412C 0-4412S	0-4412C 0-4412S	0-4412C 0-4412S
325	0-7448	0-7448	0-7448	0-4412C 0-4412S	0-4412C 0-4412S
300	Contact Holley Tech Service for a Recommendation	0-7448	0-7448	0-7448	0-4412C 0-4412S
275	Contact Holley Tech Service for a Recommendation	Contact Holley Tech Service for a Recommendation	0-7448	0-7448	0-7448
250	Contact Holley Tech Service for a Recommendation	Contact Holley Tech Service for a Recommendation	Contact Holley Tech Service for a Recommendation	0-7448	0-7448
	4000	4500	5000	5500	6000

Max Engine RPM

"We want to thank Holley for providing us with the fine products that allowed Joey Miller to win the "Rookie of the Year" title in ARCA and wind four races and sit on the pole six times. They are great products!"

Mike O'Brien,
Country Joe Racing



HOLLEY CARBS POWER EVERY NASCAR® SPRINT® CUP SERIES TEAM.

Put the same performance under your hood!



HOW TO CHOOSE A CARB
STREET CARBURETORS
SUPERCHARGER CARBURETORS
RACE CARBURETORS
MARINE CARBURETORS
CARB SERVICE PARTS & ACCESSORIES
FUEL INJECTION
THROTTLE BODIES
FUEL PUMPS
INTAKE MANIFOLDS
CYLINDER HEADS
SYSTEMAX
ENGINE DRESS-UP
MERCHANDISING
TECHNICAL INFORMATION
INDEX

Traditional Carburetors

Developed for the budget minded enthusiasts. Calibrated for use on stock to mildly modified engines.



• Smaller CFM carbs (up to 600 CFM) utilize single inlet square fuel bowls

• Larger CFM carbs (650+ CFM) utilize dual inlet center hung fuel bowls (V-Bowl), except 0-80555C

• Vacuum Secondaries for use on a wide variety of vehicles. Compensate for all vehicle weights, gearing & transmissions to allow smooth opening of secondaries

• Power Valve Blow-Out Protection

• 100% Wet-Flow Tested and calibrated for street drivability

Some available with A/T Ford kick-down. (Ford A/T kickdown, does not work with A.O.D. transmissions)

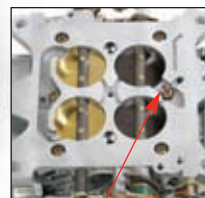
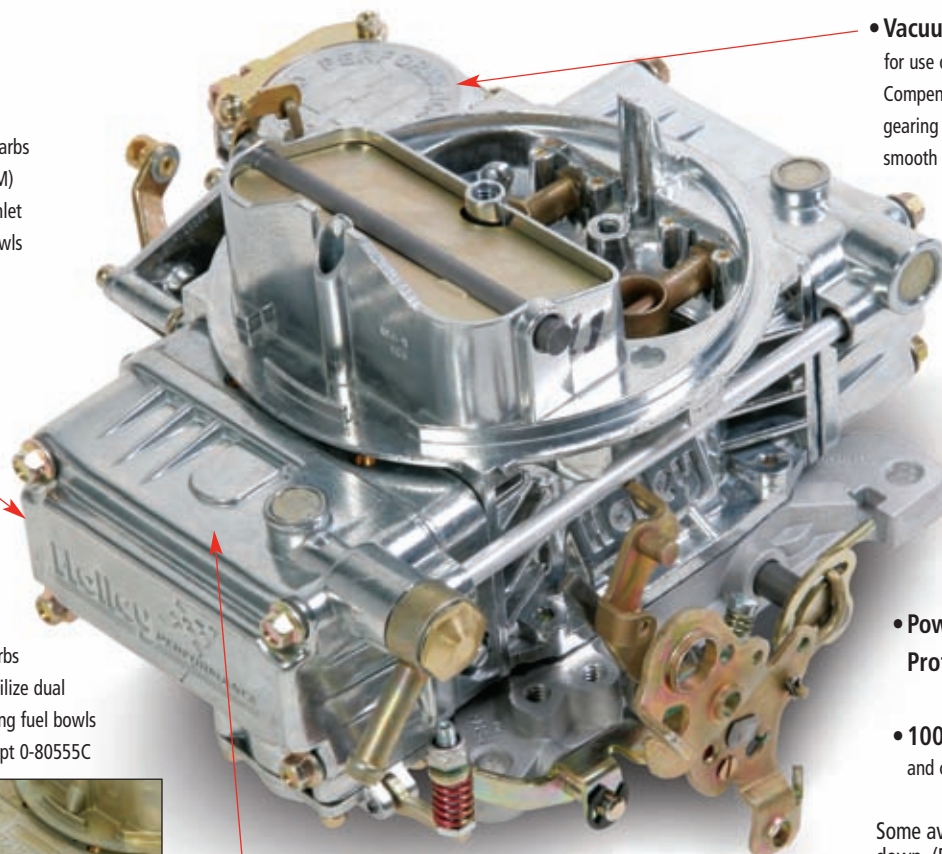

Available in Vibratory Polished Finish

For show quality looks

OR

Available in Dichromate Finish

For corrosion resistance



Description	Dichromate	Shiny
390 CFM Four Barrel Square flange, Square Bowl, electric choke	Part # 0-8007 ^(B) 3	n/a
465 CFM Four Barrel Square flange, Square Bowl, hot air choke	Part # 0-1848-1 ^(A) 1	n/a
600 CFM Four Barrel Square flange, Square Bowl, manual choke	Part # 0-1850C ^(B) 3	Part # 0-1850S ^(B) 2
600 CFM Four Barrel Square flange, Square Bowl, electric choke	n/a	Part # 0-80457S ^(A) 2
650 CFM Four Barrel Square flange, V-Bowl, electric choke	Part # 0-80783C ^(B) 3	n/a
650 CFM Four Barrel Spread Bore, electric choke (will not fit Ford or Mopar) GM only	Part # 0-80555C ^(B) 1	n/a
750 CFM Four Barrel Square flange, V-Bowl, manual choke	Part # 0-3310C ^(B) 3	Part # 0-3310S ^(B) 3
750 CFM Four Barrel Square flange, V-Bowl, electric choke	n/a	Part # 0-80508S ^(B) 1
850 CFM Four Barrel Square flange, V-Bowl, electric choke	Part # 0-80531 ^(B) 3	n/a

See pages 22-30 for individual carb details

Traditional Street Carburetors

Use this chart to determine CFM sizing for mildly modified and Stock Replacement engines used in daily drivers and trucks

Cubic Inches	450	0-1850S / 0-80457S 0-80450 / 0-80451 0-80452 / 0-80453	0-1850S / 0-80457S 0-80450 / 0-80451 0-80452 / 0-80453	0-1850S / 0-80457S 0-80450 / 0-80451 0-80452 / 0-80453	0-1850S / 0-80457S 0-80450 / 0-80451 0-80452 / 0-80453	0-9895 0-80555C 0-80783C	0-3310S 0-80508S
	400	0-1850S / 0-80457S 0-80450 / 0-80451 0-80452 / 0-80453	0-1850S / 0-80457S 0-80450 / 0-80451 0-80452 / 0-80453	0-1850S / 0-80457S 0-80450 / 0-80451 0-80452 / 0-80453	0-1850S / 0-80457S 0-80450 / 0-80451 0-80452 / 0-80453	0-1850S / 0-80457S 0-80450 / 0-80451 0-80452 / 0-80453	0-9895 0-80555C 0-80783C
	375	0-8007	0-1850S / 0-80457S 0-80450 / 0-80451 0-80452 / 0-80453	0-1850S / 0-80457S 0-80450 / 0-80451 0-80452 / 0-80453	0-1850S / 0-80457S 0-80450 / 0-80451 0-80452 / 0-80453	0-1850S / 0-80457S 0-80450 / 0-80451 0-80452 / 0-80453	0-1850S / 0-80457S 0-80450 / 0-80451 0-80452 / 0-80453
	350	0-8007	0-8007	0-1850S / 0-80457S 0-80450 / 0-80451 0-80452 / 0-80453	0-1850S / 0-80457S 0-80450 / 0-80451 0-80452 / 0-80453	0-1850S / 0-80457S 0-80450 / 0-80451 0-80452 / 0-80453	0-1850S / 0-80457S 0-80450 / 0-80451 0-80452 / 0-80453
	325	0-8007	0-8007	0-8007	0-1850S / 0-80457S 0-80450 / 0-80451 0-80452 / 0-80453	0-1850S / 0-80457S 0-80450 / 0-80451 0-80452 / 0-80453	0-1850S / 0-80457S 0-80450 / 0-80451 0-80452 / 0-80453
	300	Contact Holley Tech Service for a Recommendation	0-8007	0-8007	0-8007	0-1850S / 0-80457S 0-80450 / 0-80451 0-80452 / 0-80453	0-1850S / 0-80457S 0-80450 / 0-80451 0-80452 / 0-80453
	275	Contact Holley Tech Service for a Recommendation	Contact Holley Tech Service for a Recommendation	0-8007	0-8007	0-8007	0-1850S / 0-80457S 0-80450 / 0-80451 0-80452 / 0-80453
	250	Contact Holley Tech Service for a Recommendation	Contact Holley Tech Service for a Recommendation	Contact Holley Tech Service for a Recommendation	0-8007	0-8007	0-8007
			4000	4500	5000	5500	6000

Max Engine RPM

"When it came time for SO-CAL to finish the Spencer² hiboy roadster for car collector Dennis Higginbotham, all agreed a pair of Holley carbs and fuel pump was the only way to go to show we were serious about performance."

Pete Chapouris,
SO-CAL Speed Shop



HOLLEY CARBS POWER EVERY NASCAR® SPRINT® CUP SERIES TEAM.

Put the same performance under your hood!



NASCAR® and NASCAR Performance® are registered trademarks of the National Association of Stock Car Auto Racing, Inc.

(B) Not legal for sale or use in California on any pollution controlled motor vehicles.

Street Avenger™ Carburetors - Model 4150™ Vacuum Secondary

Square flange bolt pattern. Performance calibrated. The ultimate vacuum secondary street performance upgrade.



No Trouble® Quick Change Adjustable Vacuum Secondary

- Comes calibrated specifically for optimal street performance
- Tuneable from mild to wild
- Up to 6% more acceleration or 5% better fuel economy with a simple spring change (springs included)



- ### Gen IV No Trouble® Power Valve
- Fourth generation power valve with million mile blowout protection

No Trouble® Electric Choke

- Factory calibrated settings
- Range identified and restricted for easy on vehicle No Trouble™ adjustment
- Provides a cleaner, smoother warm up in all temperature climates
- External choke vent

Secondary Metering Block

Allows easy tuning of rear jets

Four Vacuum Ports

- PCV
- Spark
- Power brake
- Vacuum accessories (A/C or modulator)
- No Trouble caps included

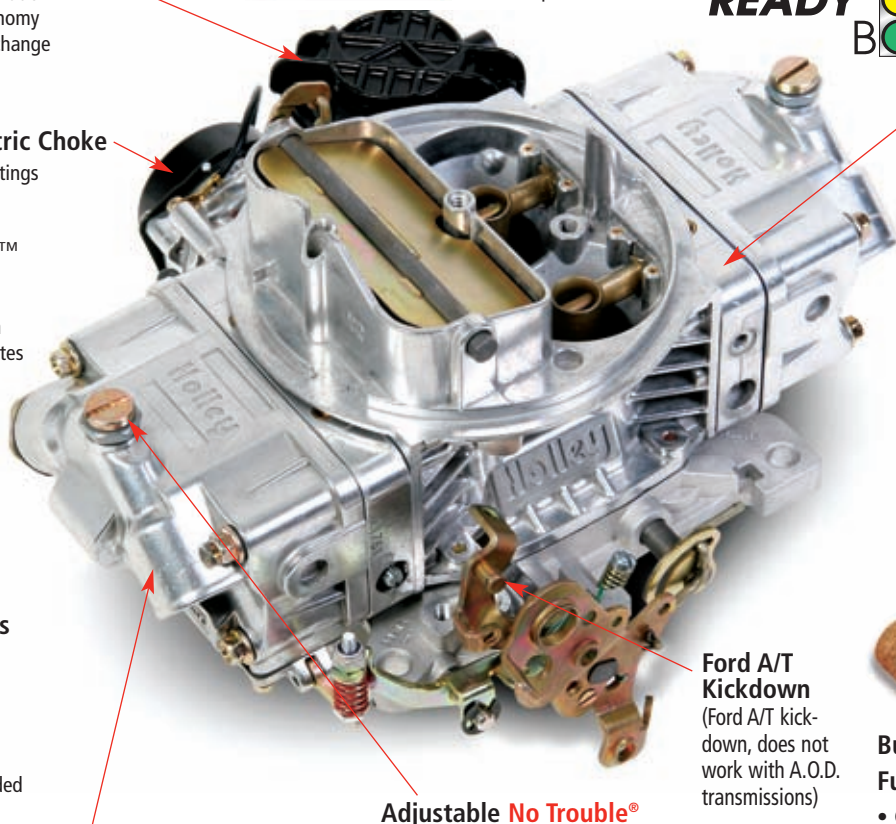

Street Avenger™ Fuel Metering System

- Provides precise fuel metering for monster low-end torque, awesome acceleration and unmatched top-end horsepower
- Designed specifically for the street enthusiast
- Tuneable to provide the ultimate in performance
- 100% wet flowed by skilled craftsmen



Built-in No Trouble® Fuel Inlet Filters

- Cleaner, safer, street performance
- Used in primary and secondary fuel bowls
- Fuel line kit included

Ford A/T Kickdown
(Ford A/T kick-down, does not work with A.O.D. transmissions)

Adjustable No Trouble® Needle & Seat

- On vehicle float adjustment to accommodate varying fuel pressure levels
- Clear sight plugs included for safe initial float level adjustment
- Clear sight window on aluminum Street Avengers



See page 224 for details

NOW AVAILABLE IN ALUMINUM
FOR WEIGHT SAVINGS AND LONG LASTING SHINE!

	Shiny Zinc	Shiny Aluminum <i>NEW</i>
ELECTRIC CHOKE		
570 CFM Four Barrel	Part # 0-80570 ^(B) ⚡	n/a
670 CFM Four Barrel	Part # 0-80670 ^(B) ⚡	Part # 0-83670 ^(B) ⚡
770 CFM Four Barrel	Part # 0-80770 ^(B) ⚡	Part # 0-83770 ^(B) ⚡
870 CFM Four Barrel	Part # 0-80870 ^(B) ⚡	n/a
MANUAL CHOKE		
570 CFM Four Barrel	Part # 0-81570 ^(B) ⚡	n/a
670 CFM Four Barrel	Part # 0-81670 ^(B) ⚡	Part # 0-85670 ^(B) ⚡
770 CFM Four Barrel	Part # 0-81770 ^(B) ⚡	Part # 0-85770 ^(B) ⚡
870 CFM Four Barrel	Part # 0-81870 ^(B) ⚡	n/a



HOW TO CHOOSE A CARB
STREET CARBURETORS
SUPERCHARGER CARBURETORS
RACE CARBURETORS
MARINE CARBURETORS
CARB SERVICE PARTS & ACCESSORIES
FUEL INJECTION
THROTTLE BODIES
FUEL PUMPS
INTAKE MANIFOLDS
CYLINDER HEADS
SYSTEMAX
ENGINE DRESS-UP
MERCHANDISING
TECHNICAL INFORMATION
INDEX

Street Avenger Carburetors

Use this chart to determine CFM sizing for typical Street and Street / Strip engines with ported heads (or aftermarket), headers, cam and aftermarket intake

Cubic Inches	475	0-80770 0-81770 0-83770 0-85770	0-80770 0-81770 0-83770 0-85770	0-80770 0-81770 0-83770 0-85770	0-80870 0-81870	0-80870 0-81870
	450	0-80770 0-81770 0-83770 0-85770	0-80770 0-81770 0-83770 0-85770	0-80770 0-81770 0-83770 0-85770	0-80770 0-81770 0-83770 0-85770	0-80870 0-81870
	400	0-80670 0-81670 0-83670 0-85670	0-80770 0-81770 0-83770 0-85770	0-80770 0-81770 0-83770 0-85770	0-80770 0-81770 0-83770 0-85770	0-80770 0-81770 0-83770 0-85770
	375	0-80670 0-81670 0-83670 0-85670	0-80670 0-81670 0-83670 0-85670	0-80770 0-81770 0-83770 0-85770	0-80770 0-81770 0-83770 0-85770	0-80770 0-81770 0-83770 0-85770
	350	0-80570 0-80670 0-81570 0-81670 0-83670 0-85670	0-80670 0-81670 0-83670 0-85670	0-80670 0-81670 0-83670 0-85670	0-80770 0-81770 0-83770 0-85770	0-80770 0-81770 0-83770 0-85770
	325	0-80570 0-81570	0-80570 0-80670 0-81570 0-81670 0-83670 0-85670	0-80670 0-81670 0-83670 0-85670	0-80670 0-81670 0-83670 0-85670	0-80770 0-81770 0-83770 0-85770
	300	0-80570 0-81570	0-80570 0-81570	0-80670 0-81670 0-83670 0-85670	0-80670 0-81670 0-83670 0-85670	0-80670 0-81670 0-83670 0-85670
		5000	5500	6000	6500	7000

Max Engine RPM

"With our experience over the years, we know what to use for complete satisfaction. We chose a Holley carb and fuel pump for the Posies Aeroliner Sport."

POSIES



HOLLEY CARBS POWER EVERY NASCAR® SPRINT® CUP SERIES TEAM.

Put the same performance under your hood!



Off-Road Truck Avenger™ Carburetors - Model 4150™ Vacuum Secondary



Square flange bolt pattern. Performance upgrade designed for extreme off-road/off-angle use. Not recommended for street trucks or towing.

Exclusive **No Trouble®** Metering Block eliminates fuel spillover through the boosters at extreme angles. Flood-free operation up to 40° while climbing; 30° during side hill maneuvers and "nose down" descents. No more hesitation, stalling or flooding. Secondary metering block allows easy tuning of rear jets.

Exclusive **No Trouble®** One-piece Off-Road Vent Tube eliminates fuel spillover during extreme maneuvers.

No Trouble® Adjustable Vacuum Secondary: a 60 second adjustment lets you tune for fuel economy or acceleration.

No Trouble® Electric Choke ensures great cold starting. Factory pre-set, easily adjustable and designed to prevent accidental over-adjustment.

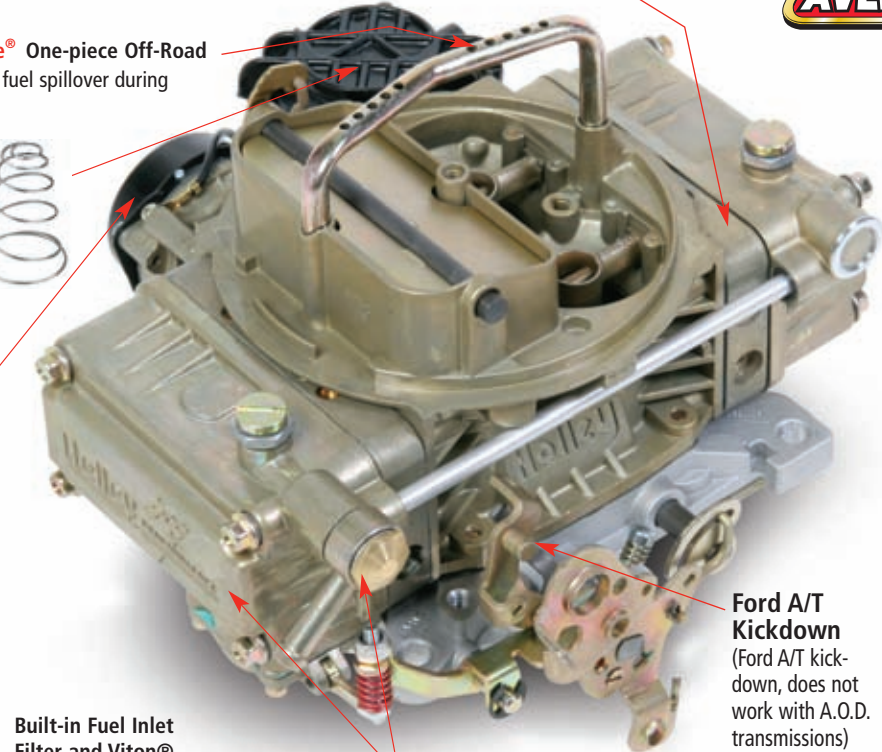

Clear Sight Plugs included to initially set fuel level without the risk of spilling fuel.

Four Vacuum Ports: PCV, spark, power brake and vacuum accessories for easy installation and great off-road performance.



Ford A/T Kickdown (Ford A/T kick-down, does not work with A.O.D. transmissions)

Built-in Fuel Inlet Filter and Viton® Transfer Tube Seals ensure leak-proof **No Trouble®** operation.



Square Fuel Bowls w/ Side Hung Floats: provide precise fuel control and maintain the classic Holley look. Single fuel inlet banjo fitting.

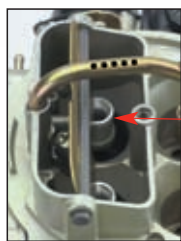

H.V.S. Annular Boosters provide an ultra High Vacuum Signal for incredible low & mid range throttle response and torque. (0-90670 & 0-90770 only)

Externally Adjustable, No Trouble® Spring-loaded Needle and Seats promote stable fuel levels for improved fuel control under all conditions.



Description	Dichromate Zinc	Dichromate Aluminum
470 CFM Four Barrel for 6 cyl	Part # 0-90470 (B) ⚡	n/a
670 CFM Four Barrel for stock to 400HP.	Part # 0-90670 (B) ⚡	Part # 0-93670 (B) ⚡
770 CFM Four Barrel for 400+ HP.	Part # 0-90770 (B) ⚡	Part # 0-93770 (B) ⚡



NOW AVAILABLE IN ALUMINUM
FOR WEIGHT SAVINGS, WEIGHS ONLY ? POUNDS!



See page 224 for details

Viton® is a registered trademark of DuPont Performance Elastomers

HOW TO CHOOSE A CARB
STREET CARBURETORS
SUPERCHARGER CARBURETORS
RACE CARBURETORS
MARINE CARBURETORS
CARB SERVICE PARTS & ACCESSORIES
FUEL INJECTION
THROTTLE BODIES
FUEL PUMPS
INTAKE MANIFOLDS
CYLINDER HEADS
SYSTEMS
ENGINE DRESS-UP
MERCHANDISING
TECHNICAL INFORMATION
INDEX

Truck Avenger Carburetors

Use this chart to determine CFM sizing for an off road vehicle that will be used primarily for low rpm climbing and rock crawling manoeuvres. Not intended for towing applications.

Cubic Inches	450	0-90670 0-93670	0-90770 0-93770	0-90770 0-93770	0-90770 0-93770	0-90770 0-93770
	400	0-90670 0-93670	0-90770 0-93770	0-90770 0-93770	0-90770 0-93770	0-90770 0-93770
	375	0-90670 0-93670	0-90670 0-93670	0-90670 0-93670	0-90770 0-93770	0-90770 0-93770
	350	0-90470	0-90470	0-90670 0-93670	0-90670 0-93670	0-90770 0-93770
	325	0-90470	0-90470	0-90470	0-90670 0-93670	0-90670 0-93670
	300	Contact Holley Tech service for a Recommendation	0-90470	0-90470	0-90470	0-90670 0-93670
	275	Contact Holley Tech service for a Recommendation	Contact Holley Tech service for a Recommendation	0-90470	0-90470	0-90470
	250	Contact Holley Tech service for a Recommendation	Contact Holley Tech service for a Recommendation	Contact Holley Tech service for a Recommendation	0-90470	0-90470
		4000	4500	5000	5500	6000

Max Engine RPM

"I've had my Jeep in places other carbureted vehicles couldn't go...hill climbs, off-camber ravine crawls, rock crawling, mud...you name it. Afterwards, I've been asked what kind of fuel injection I'm running... I enjoy seeing the look on their faces when I tell them it's a Holley Truck Avenger carburetor! I've even had to lift the hood to prove it!"

Jack Brinks
Staff Writer
Rockcrawler.com

Go to HolleyTV.com to see the Truck Avenger in action!



HOLLEY CARBS POWER EVERY NASCAR® SPRINT® CUP SERIES TEAM.

Put the same performance under your hood!



Double Pumper® Carburetors - Model 4150™ Mechanical Secondaries



Performance upgrade for hot street cars & race vehicles. For use with lightweight vehicles with manual transmissions/ automatic transmissions with high stall & low rear-end gears. Mechanical secondaries means your foot controls the opening of the secondary throttle blades.

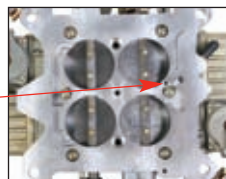

Power Valve Blow-out Protection: for trouble-free operation

Manual Choke: for easy control of engine warm-up (electric choke upgrade kits are available)

Center Hung Floats provide stable fuel control under performance conditions

Dual Metering Blocks: allow fine tuning of primary & secondary jetting

Dual Feed Fuel Inlets: for constant high volume fuel delivery

4-corner idle system for precise idle control (0-4779 & 0-4781 only)

100% Wet-flow Tested and Calibrated

Mechanical Secondaries (Dual Accelerator Pumps): for additional fuel under initial acceleration - awesome tire-turning performance for lightweight vehicles and vehicles with manual transmissions or low gearing

Description	Dichromate Zinc	Shiny Zinc
600 CFM Four Barrel square flange	Part # 0-4776C ^(B) ⚡	Part # 0-4776S ^(B) ⚡
650 CFM Four Barrel square flange	Part # 0-4777C ^(B) ⚡	Part # 0-4777S ^(B) ⚡
700 CFM Four Barrel square flange	Part # 0-4778C ^(B) ⚡	Part # 0-4778S ^(B) ⚡
750 CFM Four Barrel square flange	Part # 0-4779C ^(B) ⚡	Part # 0-4779S ^(B) ⚡
800 CFM Four Barrel square flange	Part # 0-4780C ^(B) ⚡	Part # 0-4780S ^(B) ⚡
850 CFM Four Barrel square flange	Part # 0-4781C ^(B) ⚡	Part # 0-4781S ^(B) ⚡



HOW TO CHOOSE A CARB
STREET CARBURETORS
SUPERCHARGER CARBURETORS
RACE CARBURETORS
MARINE CARBURETORS
CARB SERVICE PARTS & ACCESSORIES
FUEL INJECTION
THROTTLE BODIES
FUEL PUMPS
INTAKE MANIFOLDS
CYLINDER HEADS
SYSTEMAX
ENGINE DRESS-UP
MERCHANDISING
TECHNICAL INFORMATION
INDEX

(A) Not legal for street use in California on vehicles originally equipped with 2-barrel carburetors for which there was no 4-barrel option.

(B) Not legal for sale or use in California on any pollution controlled motor vehicles.

Double Pumper® Carburetors

Use this chart to determine CFM sizing only if you have a very efficient hot street, drag race or circle track engine with quality porting, high lift / duration camshaft profile, high compression ratios and efficient intake and exhaust componentry

<i>Cubic Inches</i>	550	0-4780C 0-4780S	0-4781C 0-4781S	Contact Holley Tech Service for a Recommendation	Contact Holley Tech Service for a Recommendation	Contact Holley Tech Service for a Recommendation	Contact Holley Tech Service for a Recommendation
	525	0-4779C 0-4779S	0-4780C 0-4780S	0-4781C 0-4781S	Contact Holley Tech Service for a Recommendation	Contact Holley Tech Service for a Recommendation	Contact Holley Tech Service for a Recommendation
	500	0-4778C 0-4778S	0-4779C 0-4779S	0-4780C 0-4780S	0-4781C 0-4781S	Contact Holley Tech Service for a Recommendation	Contact Holley Tech Service for a Recommendation
	475	0-4777C 0-4777S	0-4778C 0-4778S	0-4780C 0-4780S	0-4781C 0-4781S	0-4781C 0-4781S	Contact Holley Tech Service for a Recommendation
	450	0-4776C 0-4776S	0-4777C 0-4777S	0-4779C 0-4779S	0-4780C 0-4780S	0-4781C 0-4781S	Contact Holley Tech Service for a Recommendation
	400	0-4776C 0-4776S	0-4776C 0-4776S	0-4777C 0-4777S	0-4778C 0-4778S	0-4779C 0-4779S	0-4780C 0-4780S
	375	Contact Holley Tech Service for a Recommendation	0-4776C 0-4776S	0-4776C 0-4776S	0-4777C 0-4777S	0-4778C 0-4778S	0-4779C 0-4779S
	350	Contact Holley Tech Service for a Recommendation	Contact Holley Tech Service for a Recommendation	0-4776C 0-4776S	0-4776C 0-4776S	0-4777C 0-4777S	0-4778C 0-4778S
	325	Contact Holley Tech Service for a Recommendation	Contact Holley Tech Service for a Recommendation	Contact Holley Tech Service for a Recommendation	0-4776C 0-4776S	0-4776C 0-4776S	0-4777C 0-4777S
	300	Contact Holley Tech Service for a Recommendation	Contact Holley Tech Service for a Recommendation	Contact Holley Tech Service for a Recommendation	Contact Holley Tech Service for a Recommendation	0-4776C 0-4776S	0-4776C 0-4776S
		5000	5500	6000	6500	7000	7500

Max Engine RPM

"I've been building cars for over 30 years, and when I want maximum performance, nothing gets the job done like a Holley Double Pumper!"

— Chuck Hanson,
Horsepower TV Host



HOLLEY CARBS POWER EVERY NASCAR® SPRINT® CUP SERIES TEAM.

Put the same performance under your hood!



Street HP™ Carburetors - Model 4150™



BEST VALUE light competition carburetors!
Famous HP main body with Street/Strip metering

Quick Change Vacuum secondaries:
allow tailoring for large variety of vehicle weights/traction(0-82750 only); mechanical secondaries version also available

High Strength Sealing Surfaces:
Precision machined to tight tolerances for unsurpassed sealing

Power Valve Blow-out Protection

Tumble polished shiny finish for great looks

All necessary vacuum ports:
for easy street vehicle installation

Street/Strip calibration:
For outstanding throttle response and drivability

100% wet flow tested & calibrated

Contoured Venturii Inlet:

- For maximum air flow & reduced turbulence
- Symmetrical venturii bores offer balanced air flow for increased horsepower.

Screw-In Air Bleeds:

- Changeable air bleeds offer precision tuning capabilities

Spun-In Boosters:
For a perfect tight fit

Ford A/T Kickdown
(Ford A/T kickdown, does not work with A.O.D. transmissions)

Lightweight Slotted Mixture Screws:

- For precise settings; won't vibrate loose & can't be bumped out of adjustment
- Two corner idle system (on vacuum secondaries)
- Four corner idle system (mechanical secondary versions)

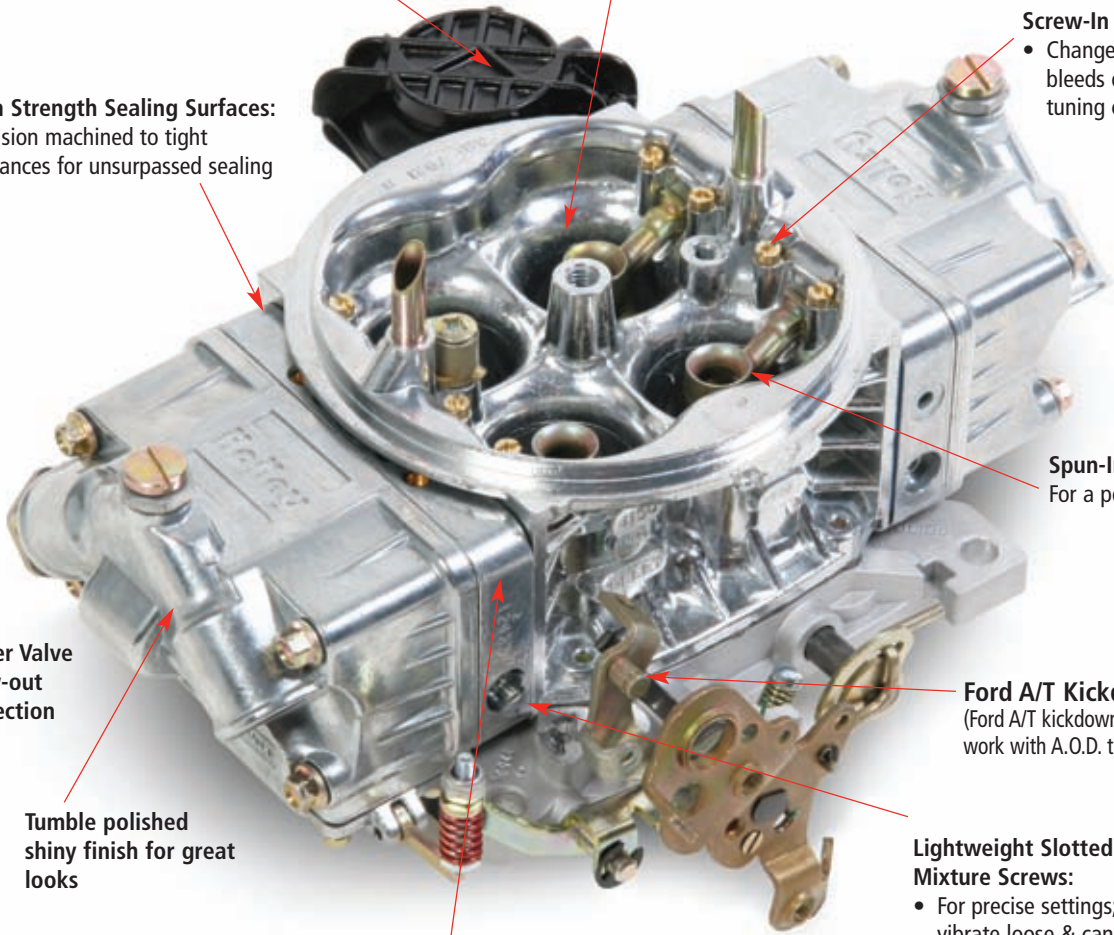

Description	Shiny Zinc
650 CFM Four Barrel square flange, mechanical secondaries	Part # 0-82651^(B) Ⓜ
750 CFM Four Barrel square flange, vacuum Secondaries	Part # 0-82750^(B) Ⓜ
750 CFM Four Barrel square flange, mechanical secondaries	Part # 0-82751^(B) Ⓜ

Street HP Carburetors

Use this chart to determine CFM sizing for typical Street and Street/Strip engines with ported heads (or aftermarket), headers, cam and aftermarket intake. Recommend high stall converter, low rearend gears for mechanical secondary use.

Cubic Inches

475	0-82750 0-82751	0-82750 0-82751	0-82750 0-82751	Contact Holley Tech Service for a Recommendation	Contact Holley Tech Service for a Recommendation	Contact Holley Tech Service for a Recommendation
450	0-82750 0-82751	0-82750 0-82751	0-82750 0-82751	0-82750 0-82751	Contact Holley Tech Service for a Recommendation	Contact Holley Tech Service for a Recommendation
400	0-82651	0-82750 0-82751	0-82750 0-82751	0-82750 0-82751	0-82750 0-82751	Contact Holley Tech Service for a Recommendation
375	0-82651	0-82651	0-82750 0-82751	0-82750 0-82751	0-82750 0-82751	0-82750 0-82751
350	0-82651	0-82651	0-82651	0-82750 0-82751	0-82750 0-82751	0-82750 0-82751
325	Contact Holley Tech Service for a Recommendation	0-82651	0-82651	0-82651	0-82750 0-82751	0-82750 0-82751
300	Contact Holley Tech Service for a Recommendation	Contact Holley Tech Service for a Recommendation	0-82651	0-82651	0-82651	0-82750 0-82751
	5000	5500	6000	6500	7000	7500

Max Engine RPM

"We used a Street HP on our Project G28 Camaro and it performed flawlessly out of the box. Good street manners, but the power is there when we needed it".

— Johnny Hunkins,
Editor, Popular Hot Rodding Magazine



HOLLEY CARBS POWER EVERY NASCAR® SPRINT® CUP SERIES TEAM.

Put the same performance under your hood!



HOW TO CHOOSE A CARB
STREET CARBURETORS
SUPERCHARGER CARBURETORS
RACE CARBURETORS
MARINE CARBURETORS
CARB SERVICE PARTS & ACCESSORIES
FUEL INJECTION
THROTTLE BODIES
FUEL PUMPS
INTAKE MANIFOLDS
CYLINDER HEADS
SYSTEMAX
ENGINE DRESS-UP
MERCHANDISING
TECHNICAL INFORMATION
INDEX

HOW TO CHOOSE A CARB
STREET CARBURETORS
SUPERCHARGER CARBURETORS
RACE CARBURETORS
MARINE CARBURETORS
CARB SERVICE PARTS & ACCESSORIES
FUEL INJECTION
THROTTLE BODIES
FUEL PUMPS
INTAKE MANIFOLDS
CYLINDER HEADS
SYSTEMAX
ENGINE DRESS-UP
MERCHANDISING
TECHNICAL INFORMATION
INDEX

STREET



Model 2300™

350 CFM Two Barrel

Part # 0-7448^(B) 3

Features

- Manual choke
- 30cc accelerator pump
- 1 timed (spark) port & 1 PCV port
- Intended as stock performance replacement for 2-bbl street applications. Also mandated carbs for some oval track racing sanctioning bodies.
- Ford A/T kickdown, does not work with A.O.D. transmissions
- Does not work with A.O.D. transmissions
- Installation & Tuning DVD included
- See pages 10 & 11 for more details & applications



OPTIONAL PARTS & KITS

P/N	DESCRIPTION
20-7	Chrysler throttle lever extension
20-9	Throttle solenoid bracket
45-223	Electric choke kit
45-228	Manual choke control cable
46-74	Throttle solenoid

STREET



Model 4160™

390 CFM Four Barrel

Part # 0-8007^(B) 3

Features

- Vacuum secondaries allow use on wide variety of vehicles
- Electric choke for easy warm up
- Single feed fuel inlet
- 1 timed (spark) port, 1 full vacuum, and 1 PCV port
- Intended for small V-8 or 6 cyl. engines & 2 x 4 street tunnel ram set-ups
- Ford A/T kickdown, does not work with A.O.D. transmissions
- Installation & Tuning DVD included
- See pages 12 & 13 for more details & applications



OPTIONAL PARTS & KITS

P/N	DESCRIPTION
20-59	Quick change secondary spring kit
20-88	GM Throttle cable/return spring bracket kit
34-2	Center hung float bowl kit
34-6	Secondary metering block
20-95	GM A.O.D. transmission bracket kit
17-6	Spread bore manifold adapter
20-124	Universal installation kit
20-121	700R-4 kickdown throttle arm
20-91	Ford kickdown spring & bracket

STREET



Model 4160™

465 CFM Four Barrel

Part # 0-1848-1^(A) 1

Features

- Vacuum secondaries allow use on wide variety of vehicles
- Hot air choke
- Single feed fuel inlet
- 1 timed (spark) port
- Intended for small V-8 engines
- Not compatible with Ford A/T with kickdown mounted on carb
- Installation & Tuning DVD included
- See pages 12 & 13 for more details & applications



OPTIONAL PARTS & KITS

P/N	DESCRIPTION
45-226	Electric choke conversion
20-59	Quick change secondary spring kit
20-88	Throttle cable/return spring bracket kit - GM
20-124	Universal installation kit

NOTE: Designed for small displacement Ford applications - not compatible with GM or Chrysler automatic transmissions
Emissions legal for some vehicles - see page 32 & 33

OFF-ROAD



Model 4150™

470 CFM Four Barrel

Part # 0-90470^(B) 3

Features

- No Trouble® quick change vacuum secondaries
- Vacuum secondaries allow use on wide variety of vehicles
- Electric choke for easy warm up
- Single feed fuel inlet
- 1 timed (spark) port, 2 full vacuum, and 1 PCV port
- Ford A/T kickdown, does not work with A.O.D. transmissions
- Intended for off-road/off-angle use. Designed for flood free operation up to 40° while climbing; 30° during side hill maneuvers & "nose down" decents
- Not intended for use on towing applications
- Installation & Tuning DVD included
- See page 16 & 17 for more details & applications



OPTIONAL PARTS & KITS

P/N	DESCRIPTION
20-88	GM Throttle cable/return spring bracket kit
17-6	Spread bore manifold adapter
20-124	Universal installation kit
20-95	GM A.O.D. transmission bracket kit
20-91	Ford automatic transmission bracket kit
20-121	700R-4 kickdown throttle arm

STREET



Model 2300™

500 CFM Two Barrel

Part # 0-4412C^(B) - Dichromate Finish

Part # 0-4412S^(B) - Shiny Finish



Features

- Manual choke
- 50cc accelerator pump
- 1 timed (spark) port, 1 full vacuum, & 1 PCV port
- Intended as stock performance replacement for 2-bbl street applications. Also mandated carbs for some oval track racing sanctioning bodies.
- Ford A/T kickdown, does not work with A.O.D. transmissions
- Installation & Tuning DVD included
- See pages 10 & 11 for more details & applications

OPTIONAL PARTS & KITS

P/N	DESCRIPTION
20-7	Chrysler throttle lever extension
45-224	Electric choke kit (requires 45-465 dechoke kit)
45-465	Dechoke linkage for 45-224 kit
45-228	Manual choke control cable
20-91	Ford A/T kickdown bracket kit

STREET



Model 4150™

570 CFM Four Barrel

Part # 0-80570^(B) - Electric Choke

Part # 0-81570^(B) - Manual Choke



Features

- No Trouble® quick change vacuum secondaries
- Vacuum secondaries allow use on wide variety of vehicles
- Dual feed fuel inlet
- 1 timed (spark) port, 2 full vacuum, and 1 PCV port
- Ford A/T kickdown, does not work with A.O.D. transmissions
- Intended for serious street enthusiasts. Calibrated for monster low-end torque, awesome acceleration, & unmatched top-end horsepower. Bolt on & go design
- Installation & Tuning DVD included
- See pages 14 & 15 for more details & applications

OPTIONAL PARTS & KITS

P/N	DESCRIPTION
20-88	GM Throttle cable/return spring bracket kit
17-6	Spread bore manifold adapter
20-124	Universal installation kit
20-95	GM A.O.D. transmission bracket kit
20-91	Ford automatic transmission bracket kit
20-121	700R-4 kickdown throttle arm

NOTE: Includes a fuel line kit to simplify installation

STOCK REPLACEMENT



Model 4160™

600 CFM Four Barrel

Part # 0-80450^(A,E,F)



Features

- Vacuum secondaries allow use on wide variety of vehicles
- Single feed fuel inlet
- Improves performance over stock carburetor
- All emissions provisions
- Direct emissions legal bolt on replacement for some vehicles

NOTE: Emissions legal for some vehicles - see pgs. 32 & 33 for applications

OPTIONAL PARTS & KITS

P/N	DESCRIPTION
20-124	Universal installation kit
20-9	Throttle solenoid bracket
46-74	Throttle solenoid
37-1536	Renew kit
20-12	Accelerator pump cam assortment
20-2	Throttle ball assortment
20-36	Throttle & cruise control stud

STOCK REPLACEMENT



Model 4160™

600 CFM Four Barrel

Part # 0-80451^(A,E)



Features

- Vacuum secondaries allow use on wide variety of vehicles
- Single feed fuel inlet
- Improves performance over stock carburetor
- All emissions provisions
- Direct emissions legal bolt on replacement for some vehicles

NOTE: Emissions legal for some vehicles - see pgs. 32 & 33 for applications

OPTIONAL PARTS & KITS

P/N	DESCRIPTION
20-124	Universal installation kit
20-9	Throttle solenoid bracket
46-74	Throttle solenoid
37-1536	Renew kit
20-12	Accelerator pump cam assortment
20-2	Throttle ball assortment
20-36	Throttle & cruise control stud

(E) Adapter P/N 17-6 is required when using a "Square Flange" carburetor on a "Spread Bore" manifold.

(F) It is not recommended or advised that the Holley Street Legal carburetors which are listed for trucks be used on motor homes.

or See page 223 for symbol explanation.

HOW TO CHOOSE A CARB
STREET CARBURETORS
SUPERCHARGER CARBURETORS
RACE CARBURETORS
MARINE CARBURETORS
CARB SERVICE PARTS & ACCESSORIES
FUEL INJECTION
THROTTLE BODIES
FUEL PUMPS
INTAKE MANIFOLDS
CYLINDER HEADS
SYSTEMAX
ENGINE DRESS-UP
MERCHANDISING
TECHNICAL INFORMATION
INDEX

HOW TO CHOOSE A CARB
STREET CARBURETORS
SUPERCHARGER CARBURETORS
RACE CARBURETORS
MARINE CARBURETORS
CARB SERVICE PARTS & ACCESSORIES
FUEL INJECTION
THROTTLE BODIES
FUEL PUMPS
INTAKE MANIFOLDS
CYLINDER HEADS
SYSTEMAX
ENGINE DRESS-UP
MERCHANDISING
TECHNICAL INFORMATION
INDEX

STREET



Model 4160™

600 CFM Four Barrel

Part # 0-80452^(A) 1



Features

- Vacuum secondaries allow use on wide variety of vehicles
- Single feed fuel inlet
- Improves performance over stock carburetor
- All emissions provisions
- Direct emissions legal bolt on replacement for some vehicles

NOTE: Emissions legal for some vehicles - see pgs 32 & 33 for applications

OPTIONAL PARTS & KITS

P/N	DESCRIPTION
20-124	Universal installation kit
20-9	Throttle solenoid bracket
46-74	Throttle solenoid
37-1536	Renew kit
20-12	Accelerator pump cam assortment
20-2	Throttle ball assortment
20-36	Throttle & cruise control stud

STREET



Model 4160™

600 CFM Four Barrel

Part # 0-80453^(A,F) 1



Features

- Vacuum secondaries allow use on wide variety of vehicles
- Single feed fuel inlet
- Improves performance over stock carburetor
- All emissions provisions
- Direct emissions legal bolt on replacement for some vehicles

NOTE: Emissions legal for some vehicles - see pgs. 32 & 33 for applications

OPTIONAL PARTS & KITS

P/N	DESCRIPTION
20-124	Universal installation kit
20-9	Throttle solenoid bracket
46-74	Throttle solenoid
37-1536	Renew kit
20-12	Accelerator pump cam assortment
20-2	Throttle ball assortment
20-36	Throttle & cruise control stud

STREET/STRIP



Model 4160™

600 CFM Four Barrel

Part # 0-80457S^(A,E,F) 2



Features

- Vacuum secondaries allow use on wide variety of vehicles
- Electric choke for easy warm up
- Single feed fuel inlet
- Calibrated for excellent street performance
- Ford A/T kickdown, does not work with A.O.D. transmissions
- 1 timed (spark) port, 1 full vacuum, and 1 PCV port
- Performance upgrade for stock to mildly modified vehicles. Universal calibration for easy bolt-on performance
- "Next Gen" needle & seat design eliminates the need for external float level adjustment
- Installation & Tuning DVD included
- See pages 12 & 13 for more details & applications

NOTE: Emissions legal for some vehicles - see pgs. 32 & 33 for applications

OPTIONAL PARTS & KITS

P/N	DESCRIPTION
20-59	Quick change secondary spring kit
20-88	GM Throttle cable/return spring bracket kit
20-95	GM A.O.D. transmission bracket kit
17-6	Spread bore manifold adapter
20-124	Universal installation kit
20-121	700R-4 kickdown throttle arm
20-91	Ford kickdown spring & bracket

STREET/STRIP

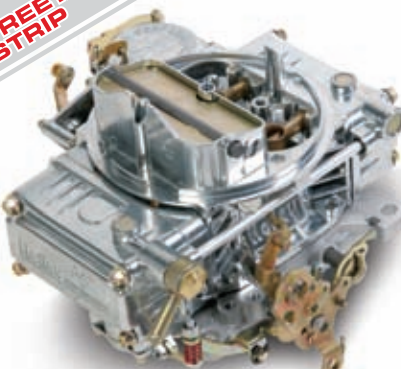

Model 4160™

600 CFM Four Barrel

Part # 0-1850C^(B) 3 - Dichromate Finish

Part # 0-1850S^(B) 3 - Shiny Finish



Features

- Vacuum secondaries allow use on wide variety of vehicles
- Manual choke
- Single feed fuel inlet
- Calibrated for excellent street performance
- Ford A/T kickdown, does not work with A.O.D. transmissions
- 1 timed (spark) port, 1 full vacuum, and 1 PCV port
- Performance upgrade for stock to mildly modified vehicles. Universal calibration for easy bolt-on performance
- "Next Gen" needle & seat design eliminates the need for external float level adjustment
- Installation & Tuning DVD included
- See pages 12 & 13 for more details & applications

OPTIONAL PARTS & KITS

P/N	DESCRIPTION
20-59	Quick change secondary spring kit
20-88	GM Throttle cable/return spring bracket kit
45-223	Electric choke kit
20-95	GM A.O.D. transmission bracket kit
17-6	Spread bore manifold adapter
45-228	Manual choke control cable
20-124	Universal installation kit
20-121	700R-4 kickdown throttle arm
20-91	Ford kickdown spring & bracket

STREET/
STRIP



Model 4150™

600 CFM Four Barrel

Part # 0-4776C^(B) 3 - Dichromate finish

Part # 0-4776S^(B) 3 - Shiny finish



Features

- Mechanical secondaries
- Dual accelerator pumps
- Manual choke
- Two corner idle
- Dual feed fuel inlet
- 1 timed (spark) port, 1 full vacuum, and 1 PCV port
- Intended for lightweight vehicles w/ manual trans or automatics with high stall & low gearing
- Installation & Tuning DVD included
- See pages 18 & 19 for more details & applications

OPTIONAL PARTS & KITS

P/N	DESCRIPTION
20-88	GM Throttle cable/return spring bracket kit
20-124	Universal installation kit
34-150	Chrome fuel line
45-224	Electric choke kit (dichromate)
45-224S	Electric choke kit (shiny)
45-228	Manual choke control cable
17-6	Spread bore manifold adapter
36-181	Jet kit
36-184	Accelerator pump tuning kit
36-182	Double Pumper tuning kit

STOCK
REPLACEMENT



Model 4165™

650 CFM Four Barrel

Part # 0-6210^(A) 1



Features

- Mechanical secondaries
- Single feed fuel inlet
- Divorced choke
- Dual accelerator pumps
- All emissions provisions
- Designed as a emissions legal performance replacement for Q-jet on certain GM applications

NOTE: Emissions legal for some vehicles - see pgs. 32 & 33 for applications
Not for Ford or Chrysler spread bore replacement

OPTIONAL PARTS & KITS

P/N	DESCRIPTION
37-605	Renew kit
20-12	Accelerator pump cam assortment
20-36	Throttle and cruise control stud
20-2	Throttle ball assortment
20-124	Universal installation kit
20-35	Transmission kickdown throttle linkage
20-47	Throttle solenoid bracket
46-74	Throttle solenoid

STREET



Model 4150™

650 CFM Four Barrel

Part # 0-80783C^(B) 3



Features

- Vacuum secondaries allow use on wide variety of vehicles
- Electric choke for easy warm up
- Dual feed fuel inlet
- Calibrated for excellent street performance
- Ford A/T kickdown, does not work with A.O.D. transmissions
- 1 timed (spark) port, 1 full vacuum, and 1 PCV port
- Performance upgrade for stock to mildly modified vehicles. Universal calibration for easy bolt-on performance
- Installation & Tuning DVD included
- See pages 12 & 13 for more details & applications

OPTIONAL PARTS & KITS

P/N	DESCRIPTION
20-59	Quick change secondary spring kit
20-88	GM Throttle cable/return spring bracket kit
34-150	Chrome fuel line
20-91	Ford automatic transmission bracket kit
17-6	Spread bore manifold adapter
20-124	Universal installation kit
20-95	GM A.O.D. transmission bracket kit
20-121	700R-4 kickdown throttle arm

STREET



Model 4175™

650 CFM Four Barrel

Part # 0-80555C^(A,F) 1



Features

- Vacuum secondaries allow use on wide variety of vehicles
- Electric choke
- Single feed fuel inlet
- Q-Jet replacement, spread bore bolt pattern
- Vacuum for: PCV,EGR, power brakes, distributor, air cleaner & canister
- Performance upgrade for stock to mildly modified vehicles. Universal calibration for easy bolt-on performance
- Installation & Tuning DVD included

NOTE: Emissions legal for some vehicles - see pgs. 32 & 33 for applications
Not for Ford or Chrysler spread bore replacement

OPTIONAL PARTS & KITS

P/N	DESCRIPTION
20-124	Universal installation kit
20-47	Throttle solenoid bracket
46-74	Throttle solenoid
20-32	GM throttle cable bracket

(E)Adapter P/N 17-6 is required when using a "Square Flange" carburetor on a "Spread Bore" manifold
(F) It is not recommended or advised that the Holley Street Legal carburetors which are listed for trucks be used on motor homes.

HOW TO
CHOOSE A CARB
CARBURETORS
STREET
CARBURETORS
SUPERCHARGER
CARBURETORS
RACE
CARBURETORS
MARINE
CARBURETORS
CARB SERVICE PARTS
& ACCESSORIES
FUEL INJECTION
THROTTLE
BODIES
FUEL PUMPS
INTAKE
MANIFOLDS
CYLINDER
HEADS
SYSTEMAX
ENGINE
DRESS-UP
MERCHANDISING
TECHNICAL
INFORMATION
INDEX

HOW TO CHOOSE A CARB
STREET CARBURETORS
SUPERCHARGER CARBURETORS
RACE CARBURETORS
MARINE CARBURETORS
CARB SERVICE PARTS & ACCESSORIES
FUEL INJECTION
THROTTLE BODIES
FUEL PUMPS
INTAKE MANIFOLDS
CYLINDER HEADS
SYSTEMAX
ENGINE DRESS-UP
MERCHANDISING
TECHNICAL INFORMATION
INDEX

STREET/
STRIP



Model 4150™

650 CFM Four Barrel

Part # 0-4777C^(B) 3 - Dichromate finish

Part # 0-4777S^(B) 3 - Shiny finish

Features

- Mechanical secondaries
- Dual accelerator pumps
- Manual choke
- Two corner idle
- Dual feed fuel inlet
- 1 timed (spark) port, 1 full vacuum, and 1 PCV port
- Intended for lightweight vehicles w/ manual trans or automatics with high stall & low gearing
- Installation & Tuning DVD included
- See pages 18 & 19 for more details & applications



OPTIONAL PARTS & KITS

P/N	DESCRIPTION
20-88	GM Throttle cable/return spring bracket kit
34-150	Chrome fuel line
45-224	Electric choke kit (dichromate)
45-224S	Electric choke kit (shiny)
45-228	Manual choke control cable
17-6	Spread bore manifold adapter
36-181	Jet kit
36-184	Accelerator pump tuning kit
36-182	Double Pumper tuning kit
20-124	Universal installation kit

STREET/
STRIP



Model 4150™

650 CFM Four Barrel

Part # 0-82651^(B) 3

Features

- Mechanical secondaries
- Dual accelerator pumps
- Adjustable air bleeds
- No choke
- Contoured venturii inlet for increased airflow
- Four corner idle for precise idle control
- Dual feed fuel inlet
- 1 timed (spark) port, 1 full vacuum, and 1 PCV port
- Intended for lightweight vehicles w/ manual trans or automatics with high stall & low gearing. Street/strip calibration for outstanding throttle response & drivability
- Ford A/T kickdown, does not work with A.O.D. transmissions
- Installation & Tuning DVD included
- See pages 20-21 for more details & applications



OPTIONAL PARTS & KITS

P/N	DESCRIPTION
20-88	GM Throttle cable/return spring bracket kit
34-150	Chrome fuel line
17-6	Spread bore manifold adapter
20-124	Universal installation kit
20-95	GM A.O.D. transmission bracket kit
20-91	Ford automatic transmission bracket kit
36-181	Jet kit
20-121	700R-4 kickdown throttle arm

STREET



Model 4150™

670 CFM Four Barrel

Part # 0-80670^(B) 3 - Electric Choke

Part # 0-81670^(B) 3 - Manual Choke

Features

- No Trouble® quick change vacuum secondaries
- Vacuum secondaries allow use on wide variety of vehicles
- Dual feed fuel inlet
- 1 timed (spark) port, 2 full vacuum, and 1 PCV port
- Ford A/T kickdown, does not work with A.O.D. transmissions
- Intended for serious street enthusiasts. Calibrated for monster low-end torque, awesome acceleration, & unmatched top-end horsepower. Bolt on & go design
- Installation & Tuning DVD included
- See pages 14 & 15 for more details & applications



OPTIONAL PARTS & KITS

P/N	DESCRIPTION
20-88	GM Throttle cable/return spring bracket kit
17-6	Spread bore manifold adapter
20-124	Universal installation kit
20-95	GM A.O.D. transmission bracket kit
20-91	Ford automatic transmission bracket kit
20-121	700R-4 kickdown throttle arm

NOTE: Includes a fuel line kit to simplify installation

STREET



LIGHTWEIGHT ALUMINUM

Model 4150™

670 CFM Four Barrel

Part # 0-83670^(B) 3 - Electric Choke

Part # 0-85670^(B) 3 - Manual Choke

Features

- Aluminum construction for added weight savings & lasting shine
- No Trouble® quick change vacuum secondaries
- Vacuum secondaries allow use on wide variety of vehicles
- Dual feed fuel inlet
- 1 timed (spark) port, 2 full vacuum, and 1 PCV port
- Ford A/T kickdown, does not work with A.O.D. transmissions
- Glass sight windows for easy, safe float adjustment
- Intended for serious street enthusiasts. Calibrated for monster low-end torque, awesome acceleration, & unmatched top-end horsepower. Bolt on & go design
- Installation & Tuning DVD included
- See pages 14 & 15 for more details & applications



OPTIONAL PARTS & KITS

P/N	DESCRIPTION
20-88	GM Throttle cable/return spring bracket kit
17-6	Spread bore manifold adapter
20-124	Universal installation kit
20-95	GM A.O.D. transmission bracket kit
20-91	Ford automatic transmission bracket kit
20-121	700R-4 kickdown throttle arm

NOTE: Includes a fuel line kit to simplify installation

OFF-ROAD



Model 4150™

670 CFM Four Barrel

Part # 0-90670^(B)

Features

- Vacuum secondaries allow use on wide variety of vehicles
- No Trouble® quick change vacuum secondaries
- Electric choke for easy warm up
- Single feed fuel inlet
- 1 timed (spark) port, 2 full vacuum, and 1 PCV port
- Ford A/T kickdown, does not work with A.O.D. transmissions
- Intended for off-road/off-angle use. Designed for flood free operation up to 40° while climbing; 30° during side hill maneuvers & "nose down" decents
- Not intended for use on towing applications
- Installation & Tuning DVD included
- See pages 16 & 17 for more details & applications



OPTIONAL PARTS & KITS

P/N	DESCRIPTION
20-88	GM Throttle cable/return spring bracket kit
17-6	Spread bore manifold adapter
20-124	Universal installation kit
20-95	GM A.O.D. transmission bracket kit
20-91	Ford automatic transmission bracket kit
20-121	700R-4 kickdown throttle arm

OFF-ROAD



LIGHTWEIGHT ALUMINUM

Model 4150™

670 CFM Four Barrel

Part # 0-93670^(B)

Features

- Aluminum construction for added weight savings with dichromate finish for corrosion resistance
- No Trouble® quick change vacuum secondaries
- Vacuum secondaries allow use on wide variety of vehicles
- Electric choke for easy warm up
- Single feed fuel inlet
- 1 timed (spark) port, 2 full vacuum, and 1 PCV port
- Ford A/T kickdown, does not work with A.O.D. transmissions
- Intended for off-road/off-angle use. Designed for flood free operation up to 40° while climbing; 30° during side hill maneuvers & "nose down" decents
- Not intended for use on towing applications
- Installation & Tuning DVD included
- See pages 16 & 17 for more details & applications



OPTIONAL PARTS & KITS

P/N	DESCRIPTION
20-88	GM Throttle cable/return spring bracket kit
17-6	Spread bore manifold adapter
20-124	Universal installation kit
20-95	GM A.O.D. transmission bracket kit
20-91	Ford automatic transmission bracket kit
20-121	700R-4 kickdown throttle arm

STREET



Model 4150™

670 CFM Four Barrel

Part # 0-80681^(B)

Features

- Vacuum secondaries allow use on wide variety of vehicles
- Electric choke for easy warm up
- Single feed fuel inlet
- 1 timed (spark) port, 2 full vacuum, and 1 PCV port
- Ford A/T kickdown, does not work with A.O.D. transmissions
- Intended for extreme hydraulic maneuvers. Designed for flood free operation up to 40° "nose up"; 30° during side to side maneuvers & "nose down"
- Shiny finish with chrome fuel bowls
- Installation & Tuning DVD included



OPTIONAL PARTS & KITS

P/N	DESCRIPTION
20-88	GM Throttle cable/return spring bracket kit
17-6	Spread bore manifold adapter
20-124	Universal installation kit
20-95	GM A.O.D. transmission bracket kit
20-91	Ford automatic transmission bracket kit
20-121	700R-4 kickdown throttle arm

STREET/
STRIP



Model 4150™

700 CFM Four Barrel

Part # 0-4778C^(B) - Dichromate finish

Part # 0-4778S^(B) - Shiny finish

Features

- Mechanical secondaries
- Dual accelerator pumps
- Manual choke
- Two corner idle
- Dual feed fuel inlet
- 1 timed (spark) port, 1 full vacuum, and 1 PCV port
- Intended for lightweight vehicles w/ manual trans or automatics with high stall & low gearing
- Installation & Tuning DVD included
- See pages 18 & 19 for more details & applications



OPTIONAL PARTS & KITS

P/N	DESCRIPTION
20-88	GM Throttle cable/return spring bracket kit
34-150	Chrome fuel line
45-224	Electric choke kit (dichromate)
45-224S	Electric choke kit (shiny)
45-228	Manual choke control cable
17-6	Spread bore manifold adapter
20-124	Universal installation kit
36-181	Jet kit
36-184	Accelerator pump tuning kit
36-182	Double Pumper tuning kit

STREET



Model 4160™

750 CFM Four Barrel

Part # 0-3310C^(B) 3 - Dichromate finish

Part # 0-3310S^(B) 3 - Shiny finish



Features

- Vacuum secondaries allow use on wide variety of vehicles
- Manual choke
- Dual feed fuel inlet
- Ford A/T kickdown, does not work with A.O.D. transmissions
- 1 timed (spark) port, 1 full vacuum, and 1 PCV port
- Performance upgrade for stock to mildly modified vehicles.
- Universal calibration for easy bolt-on performance
- Installation & Tuning DVD included
- See pages 12 & 13 for more details & applications

OPTIONAL PARTS & KITS

P/N	DESCRIPTION
20-59	Quick change secondary spring kit
20-88	GM Throttle cable/return spring bracket kit
34-160	Chrome fuel line
45-228	Manual choke control cable
20-91	Ford Automatic transmission bracket kit
17-6	Spread bore manifold adapter
34-13	4160-4150 conversion (standard finish)
34-13S	4160-4150 conversion (shiny finish)
20-124	Universal installation kit
20-95	GM A.O.D. transmission bracket kit
20-121	700R-4 kickdown throttle arm

STREET



Model 4160™

750 CFM Four Barrel

Part # 0-80508S^(A,E,F) 1 - Shiny finish



Features

- Vacuum secondaries allow use on wide variety of vehicles
- Electric choke for easy warm up
- Dual feed fuel inlet
- Ford A/T kickdown, does not work with A.O.D. transmissions
- 1 timed (spark) port, 1 full vacuum, and 1 PCV port
- Performance upgrade for stock to mildly modified vehicles.
- Universal calibration for easy bolt-on performance
- Installation & Tuning DVD included
- See pages 12 & 13 for more details & applications

OPTIONAL PARTS & KITS

P/N	DESCRIPTION
20-59	Quick change secondary spring kit
20-88	GM Throttle cable/return spring bracket kit
20-95	GM A.O.D. transmission bracket kit
20-91	Ford Automatic transmission bracket kit
34-160	Chrome fuel line
17-6	Spread bore manifold adapter
34-13S	4160-4150 conversion (shiny finish)
20-124	Universal installation kit
20-121	700R-4 kickdown throttle arm

STREET/
STRIP



Model 4150™

750 CFM Four Barrel

Part # 0-4779C^(B) 3 - Dichromate finish

Part # 0-4779S^(B) 3 - Shiny finish



Features

- Mechanical secondaries
- Dual accelerator pumps
- Manual choke
- Four corner idle
- Dual feed fuel inlet
- 1 timed (spark) port, 1 full vacuum, and 1 PCV port
- Intended for lightweight vehicles w/ manual trans or automatics with high stall & low gearing
- Installation & Tuning DVD included
- See pages 18 & 19 for more details & applications

OPTIONAL PARTS & KITS

P/N	DESCRIPTION
20-88	GM Throttle cable/return spring bracket kit
34-150	Chrome fuel line
45-224	Electric choke kit (dichromate)
45-224S	Electric choke kit (shiny)
45-228	Manual choke control cable
17-6	Spread bore manifold adapter
36-181	Jet kit
36-184	Accelerator pump tuning kit
36-182	Double Pumper tuning kit
20-124	Universal installation kit

STREET/
STRIP



Model 4150™

750 CFM Four Barrel

Part # 0-82750^(B) 3



Features

- No Trouble® quick change vacuum secondaries
- Vacuum secondaries allows use on a wide range of vehicles
- Adjustable air bleeds
- No choke
- Ford A/T kickdown, does not work with A.O.D. transmissions
- Contoured Venturii inlet for increased airflow
- Two corner idle
- Dual feed fuel inlet
- 1 timed (spark) port, 1 full vacuum, and 1 PCV port
- Street/strip calibration for outstanding throttle response & drivability
- Installation & Tuning DVD included
- See pages 20 & 21 for more details & applications

OPTIONAL PARTS & KITS

P/N	DESCRIPTION
20-88	GM Throttle cable/return spring bracket kit
34-150	Chrome fuel line
17-6	Spread bore manifold adapter
20-124	Universal installation kit
20-95	GM A.O.D. transmission bracket kit
20-91	Ford Automatic transmission bracket kit
20-121	700R-4 kickdown throttle arm
36-181	Jet kit

STREET/
STRIP



Model 4150™

750 CFM Four Barrel

Part # 0-82751^(B) Ⓜ

Features

- Mechanical secondaries
- Dual accelerator pumps
- Adjustable air bleeds
- No choke
- Contoured Venturii inlet for increased airflow
- Four corner idle for precise idle control
- Dual feed fuel inlet
- 1 timed (spark) port, 1 full vacuum, and 1 PCV port
- Intended for lightweight vehicles w/ manual trans or automatics with high stall & low gearing. Street/strip calibration for outstanding throttle response & drivability
- Installation & Tuning DVD included
- See pages 20-21 for more details & applications



OPTIONAL PARTS & KITS

P/N	DESCRIPTION
20-88	GM Throttle cable/return spring bracket kit
34-150	Chrome fuel line
17-6	Spread bore manifold adapter
20-124	Universal installation kit
20-95	GM A.O.D. transmission bracket kit
20-91	Ford automatic transmission bracket kit
20-121	700R-4 kickdown throttle arm
36-181	Jet kit

STREET



Model 4150™

770 CFM Four Barrel

Part # 0-80770^(B) Ⓜ - Electric Choke

Part # 0-81770^(B) Ⓜ - Manual Choke

Features

- No Trouble® quick change vacuum secondaries
- Vacuum secondaries allow use on wide variety of vehicles
- Dual feed fuel inlet
- 1 timed (spark) port, 2 full vacuum, and 1 PCV port
- Ford A/T kickdown, does not work with A.O.D. transmissions
- Intended for serious street enthusiasts. Calibrated for monster low-end torque, awesome acceleration, & unmatched top-end horsepower. Bolt on & go design
- Installation & Tuning DVD included
- See pages 14 & 15 for more details & applications



OPTIONAL PARTS & KITS

P/N	DESCRIPTION
20-88	GM Throttle cable/return spring bracket kit
17-6	Spread bore manifold adapter
20-124	Universal installation kit
20-95	GM A.O.D. transmission bracket kit
20-91	Ford automatic transmission bracket kit
20-121	700R-4 kickdown throttle arm

STREET



LIGHTWEIGHT ALUMINUM

Model 4150™

770 CFM Four Barrel

Part # 0-83770^(B) Ⓜ - Electric Choke

Part # 0-85770^(B) Ⓜ - Manual Choke

Features

- Aluminum construction for added weight savings & lasting shine
- No Trouble® quick change vacuum secondaries
- Vacuum secondaries allow use on wide variety of vehicles
- Dual feed fuel inlet
- 1 timed (spark) port, 2 full vacuum, and 1 PCV port
- Ford A/T kickdown, does not work with A.O.D. transmissions
- Glass sight windows for easy, safe float adjustment
- Intended for serious street enthusiasts. Calibrated for monster low-end torque, awesome acceleration, & unmatched top-end horsepower. Bolt on & go design
- Installation & Tuning DVD included
- See pages 14 & 15 for more details & applications



OPTIONAL PARTS & KITS

P/N	DESCRIPTION
20-88	GM Throttle cable/return spring bracket kit
17-6	Spread bore manifold adapter
20-124	Universal installation kit
20-95	GM A.O.D. transmission bracket kit
20-91	Ford automatic transmission bracket kit
20-121	700R-4 kickdown throttle arm

OFF-ROAD



Model 4150™

770 CFM Four Barrel

Part # 0-90770^(B) Ⓜ

Features

- No Trouble® quick change vacuum secondaries
- Vacuum secondaries allow use on wide variety of vehicles
- Electric choke for easy warm up
- Single feed fuel inlet
- 1 timed (spark) port, 2 full vacuum, and 1 PCV port
- Ford A/T kickdown, does not work with A.O.D. transmissions
- Intended for off-road/off-angle use. Designed for flood free operation up to 40° while climbing; 30° during side hill maneuvers & "nose down" descents
- Not intended for use on towing applications
- Installation & Tuning DVD included
- See pages 16 & 17 for more details & applications



OPTIONAL PARTS & KITS

P/N	DESCRIPTION
20-88	GM Throttle cable/return spring bracket kit
17-6	Spread bore manifold adapter
20-124	Universal installation kit
20-95	GM A.O.D. transmission bracket kit
20-91	Ford automatic transmission bracket kit
20-121	700R-4 kickdown throttle arm

(E)Adapter P/N 17-6 is required when using a "Square Flange" carburetor on a "Spread Bore" manifold
 (F) It is not recommended or advised that the Holley Street Legal carburetors which are listed for trucks be used on motor homes.

HOW TO CHOOSE A CARB
 STREET CARBURETORS
 SUPERCHARGER CARBURETORS
 RACE CARBURETORS
 MARINE CARBURETORS
 CARB SERVICE PARTS & ACCESSORIES
 FUEL INJECTION
 THROTTLE BODIES
 FUEL PUMPS
 INTAKE MANIFOLDS
 CYLINDER HEADS
 SYSTEMAX
 ENGINE DRESS-UP
 MERCHANDISING
 TECHNICAL INFORMATION
 INDEX

HOW TO CHOOSE A CARB
STREET CARBURETORS
SUPERCHARGER CARBURETORS
RACE CARBURETORS
MARINE CARBURETORS
CARB SERVICE PARTS & ACCESSORIES
FUEL INJECTION
THROTTLE BODIES
FUEL PUMPS
INTAKE MANIFOLDS
CYLINDER HEADS
SYSTEMAX
ENGINE DRESS-UP
MERCHANDISING
TECHNICAL INFORMATION
INDEX

OFF-ROAD



NEW

LIGHTWEIGHT ALUMINUM Model 4150™

770 CFM Four Barrel

Part # 0-93770^(B) 3

Features

- Aluminum construction for added weight savings
- No Trouble® quick change vacuum secondaries
- Vacuum secondaries allow use on wide variety of vehicles
- Electric choke for easy warm up
- Single feed fuel inlet
- 1 timed (spark) port, 2 full vacuum, and 1 PCV port
- Ford A/T kickdown, does not work with A.O.D. transmissions
- Intended for off-road/off-angle use. Designed for flood free operation up to 40° while climbing; 30° during side hill maneuvers & "nose down" decents
- Not intended for use on towing applications
- Installation & Tuning DVD included
- See pages 16 & 17 for more details & applications



OPTIONAL PARTS & KITS

P/N	DESCRIPTION
20-88	GM Throttle cable/return spring bracket kit
17-6	Spread bore manifold adapter
20-124	Universal installation kit
20-95	GM A.O.D. transmission bracket kit
20-91	Ford automatic transmission bracket kit
20-121	700R-4 kickdown throttle arm

STREET/STRIP



Model 4150™

800 CFM Four Barrel

Part # 0-4780C^(B) 3 - Dichromate finish

Part # 0-4780S^(B) 3 - Shiny finish

Features

- Mechanical secondaries
- Dual accelerator pumps (Double Pumper®)
- Manual choke
- Two corner idle
- Dual feed fuel inlet
- 1 timed (spark) port, 1 full vacuum, and 1 PCV port
- Intended for lightweight vehicles w/ manual trans or automatics with high stall & low gearing
- Installation & Tuning DVD included
- See pages 18 & 19 for more details & applications



OPTIONAL PARTS & KITS

P/N	DESCRIPTION
20-88	GM Throttle cable/return spring bracket kit
34-150	Chrome fuel line
45-224	Electric choke kit (dichromate)
45-224S	Electric choke kit (shiny)
45-228	Manual choke control cable
17-6	Spread bore manifold adapter
36-181	Jet kit
36-184	Accelerator pump tuning kit
36-182	Double Pumper tuning kit
20-124	Universal installation kit

STREET



Model 4150™

850 CFM Four Barrel

Part # 0-80531^(B) 3

Features

- Vacuum secondaries allow use on wide variety of vehicles
- Electric choke for easy warm up
- Dual feed fuel inlet
- 1 timed (spark) port, 1 full vacuum, and 1 PCV port
- Ford A/T kickdown, does not work with A.O.D. transmissions
- Performance upgrade for stock to mildly modified vehicles. Universal calibration for easy bolt-on performance. Perfect calibration for 502 crate motors
- Secondary power valve
- Installation & Tuning DVD included
- See pages 12 & 13 for more details & applications



OPTIONAL PARTS & KITS

P/N	DESCRIPTION
20-88	GM Throttle cable/return spring bracket kit
20-95	GM A.O.D. transmission bracket kit
20-59	Quick change secondary spring kit
34-150	Chrome fuel line
20-7	Chrysler throttle lever extension
17-6	Spread bore manifold adapter
20-124	Universal installation kit
20-121	700R-4 kickdown throttle arm

STREET/STRIP



Model 4150™

850 CFM Four Barrel

Part # 0-4781C^(B) 3 - Dichromate finish

Part # 0-4781S^(B) 3 - Shiny finish

Features

- Mechanical secondaries
- Dual accelerator pumps (Double Pumper®)
- Manual choke
- Four corner idle for precise idle control
- Dual feed fuel inlet
- 1 timed (spark) port, 1 full vacuum, and 1 PCV port
- Intended for lightweight vehicles w/ manual trans or automatics with high stall & low gearing
- Installation & Tuning DVD included
- See pages 18 & 19 for more details & applications



OPTIONAL PARTS & KITS

P/N	DESCRIPTION
20-88	GM Throttle cable/return spring bracket kit
34-150	Chrome fuel line
45-224	Electric choke kit (dichromate)
45-224S	Electric choke kit (shiny)
45-228	Manual choke control cable
17-6	Spread bore manifold adapter
36-181	Jet kit
36-184	Accelerator pump tuning kit
36-182	Double Pumper tuning kit
20-124	Universal installation kit

STREET



Model 4150™

870 CFM Four Barrel

Part # 0-80870^(B) - Electric Choke

Part # 0-81870^(B) - Manual Choke



Features

- No Trouble® quick change vacuum secondaries
- Vacuum secondaries allow use on wide variety of vehicles
- Dual feed fuel inlet
- 1 timed (spark) port, 2 full vacuum, and 1 PCV port
- Ford A/T kickdown, does not work with A.O.D. transmissions
- Intended for serious street enthusiasts. Calibrated for monster low-end torque, awesome acceleration, & unmatched top-end horsepower. Bolt on & go design
- Installation & Tuning DVD included
- See pages 14 & 15 for more details & applications

OPTIONAL PARTS & KITS

P/N	DESCRIPTION
20-88	GM Throttle cable/return spring bracket kit
17-6	Spread bore manifold adapter
20-124	Universal installation kit
20-95	GM A.O.D. transmission bracket kit
20-91	Ford automatic transmission bracket kit
20-121	700R-4 kickdown throttle arm

O.E. MUSCLE CAR CARBURETORS

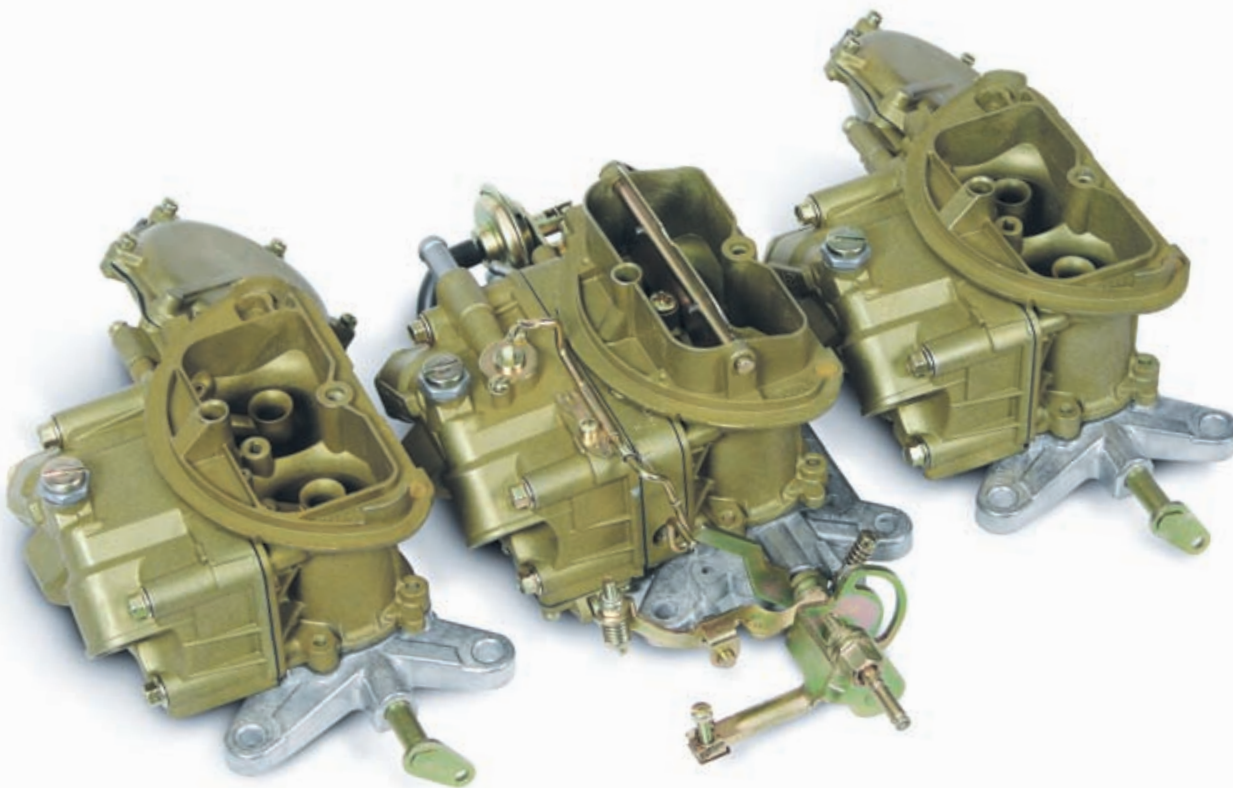

Chrysler

PART #	MODEL	O.E. NUMBER	APPLICATION	CHOKE	CFM
0-4144-1	2300	3418550	1969-70 440/390 3x2 (center carb.)	Remote	350
0-4235	4160	2946263	1968 426 Hemi (right side carb)	N/A	770
0-4236	4160	2946262	1968 426 Hemi (left side carb)	N/A	770
0-4365-1	2300	3462373	1969-70 440/390 3x2 (outboard carb.)	N/A	500
0-4790	2300	3577185	1970-71 340 3x2 (outboard carb.)	N/A	500
0-4792	2300	3577183	1970-71 340 3x2 (center carb.) A/T	Remote	350

(B) Not legal for sale or use in California on any pollution controlled motor vehicles.

See page 223 for symbol explanation.

HOW TO CHOOSE A CARB
 STREET CARBURETORS
 SUPERCHARGER CARBURETORS
 RACE CARBURETORS
 MARINE CARBURETORS
 CARB SERVICE PARTS & ACCESSORIES
 FUEL INJECTION
 THROTTLE BODIES
 FUEL PUMPS
 INTAKE MANIFOLDS
 CYLINDER HEADS
 SYSTEMAX
 ENGINE DRESS-UP
 MERCHANDISING
 TECHNICAL INFORMATION
 INDEX

HOW TO CHOOSE A CARB
STREET CARBURETORS
SUPERCHARGER CARBURETORS
RACE CARBURETORS
MARINE CARBURETORS
CARB SERVICE PARTS & ACCESSORIES
FUEL INJECTION
THROTTLE BODIES
FUEL PUMPS
INTAKE MANIFOLDS
CYLINDER HEADS
SYSTEMS
ENGINE DRESS-UP
MERCHANDISING
TECHNICAL INFORMATION
INDEX

REPLACEMENT CARBURETORS

Features

- All emission provisions
- Engineered to improve performance
- Bolt-on installation
- Square and Spread bore bolt patterns
- Vacuum and mechanical secondaries



Model 4160 Square Flange



Model 4175 Spread Bore

MAKE	YEAR	ENGINE	SQUARE FLANGE		SPREAD BORE	
			PART #	CFM	PART #	CFM
AMC	1965-69	All V8s	0-80457S v(A,E) ◆	600	N/A	N/A
Buick	1967	400	0-80457S v(A,E) ◆	600	0-80555C v(A) ◆	650
		430	0-80508S v(A,E) ◆	750	0-80555C v(A) ◆	650
	1968-69	350,400	0-80457S v(A,E) ◆	600	0-80555C v(A) ◆	650
		430,455	0-80508S v(A,E) ◆	750	N/A	N/A
	1970	350,455	0-80450 v(A,E) ◆	600	N/A	N/A
	1971	455	0-80450 v(A,E) ◆	600	N/A	N/A
	1972	350,455	0-80450 v(A,E) ◆	600	N/A	N/A
	1973-74	350,455	0-80450 v(A,E) ◆	600	N/A	N/A
1975-79	350,455	0-80451 v(A,E) ◆	600	N/A	N/A	
Chevrolet	1966-69	327,350,402	0-80457S v(A,E) ◆	600	0-80555C v(A) ◆	650
		427,454	0-80508S v(A,E) ◆	750	0-6210 m(A) ◆	650
	1970	307	0-80450 v(A,E) ◆	600	N/A	N/A
		350,402	0-80450 v(A,E) ◆	600	0-6210 m(A) ◆	650
	1971	307,350,402,454	0-80450 v(A,E) ◆	600	N/A	N/A
	1972	350,454	0-80450 v(A,E) ◆	600	N/A	N/A
	1973-74	350,454	0-80450 v(A,E) ◆	600	N/A	N/A
	1975-76	400,454	0-80451 v(A,E) ◆	600	N/A	N/A
	1975-78	350 (5.7L)	0-80451 v(A,E) ◆	600	0-9895 v(A) ◆	650
	Chevrolet/ GMC Trucks	1968	327; 396 (10 Series)	0-80457S v(A,E,F) ◆	600	0-80555C v(A,F) ◆
1969		350 (10 Series)	0-80457S v(A,E,F) ◆	600	0-80555Cv(A,F) ◆	650
		396 (10 Series)	0-80508S v(A,E,F) ◆	750	0-80555C v(A,F) ◆	650
1970-72		350 (10 Series)	0-80450 v(A,E,F) ◆	600	N/A	N/A
		402,454	0-80450 v(A,E,F) ◆	600	N/A	N/A
1973		350,454	0-80450 v(A,E,F) ◆	600	N/A	N/A
1974		350 (10,20 Series)	0-80450 v(A,E,F) ◆	600	N/A	N/A
		454	0-80450 v(A,E,F) ◆	600	N/A	N/A
1975-78		350 U8500GVW	N/A	N/A	N/A	N/A
		400 U8500GVW	N/A	N/A	N/A	N/A
1979-80	350 U8500GVW	0-80451 v(A,E,F) ◆	600	N/A	N/A	
1980-85	350 (17080213)	N/A	N/A	N/A	650	
Chrysler	1967-69	318,383	0-80457S v(A,E) ◆	600	N/A	N/A
		440	0-80508S v(A,E) ◆	750	N/A	N/A
Dodge	1967-69	318,383	0-80457S v(A,E) ◆	◆	600	N/A
		440	0-80508S v(A,E) ◆	750	N/A	N/A
Ford	1958-60	332, 352, 361	0-1848-1 v(A) ◆	465	N/A	N/A
	1961-67	All V-8	0-80457S v(A) ◆	600	N/A	N/A
	1968-69	302,351W	0-80457S v(A) ◆	600	N/A	N/A
		390,428	0-80508S v(A) ◆	750	N/A	N/A
	1970-72	390	0-80453 v(A) ◆	600	N/A	N/A
	1970-74	302	0-80453 v(A) ◆	600	N/A	N/A
1977-78	351M	0-80453 v(A) ◆	600	N/A	N/A	



MAKE	YEAR	ENGINE	SQUARE FLANGE		SPREAD BORE	
			PART #	CFM	PART #	CFM
Ford Truck	1968-69	302,360	0-80457S v(A,F) ◆	600	N/A	N/A
		390,428,429	0-80508S v(A,F) ◆	750	N/A	N/A
	1970-72	360,390	0-80453 v(A,F) ◆	600	N/A	N/A
	1970-74	302	0-80453 v(A,F) ◆	600	N/A	N/A
	1975-76	460 (Ranchero)	0-80452 v(A) ◆	600	N/A	N/A
		390 PU U8500GVW	0-80452 v(A) ◆	600	N/A	N/A
	1975-77	351W	0-80452 v(A) ◆	600	N/A	N/A
	1975-80	460 Van U8500GVW	0-80452 v(A) ◆	600	N/A	N/A
		460 PU U8500GVW	0-80452 v(A) ◆	600	N/A	N/A
1977-80	351M,400	0-80452 v(A) ◆	600	N/A	N/A	
1979-80	302	0-80452 v(A) ◆	600	N/A	N/A	
Mercury	1958-60	332, 352, 361	0-1848-1 v(A) ◆	450	N/A	N/A
	1961-67	All V-8	0-80457S v(A) ◆	600	N/A	N/A
	1968-69	302,351W	0-80457S v(A) ◆	600	N/A	N/A
		390,428	0-80508S v(A) ◆	750	N/A	N/A
	1970-72	390	0-80453 v(A) ◆	600	N/A	N/A
	1970-74	302	0-80453 v(A) ◆	600	N/A	N/A
	1977-78	351M	0-80453 v(A) ◆	600	N/A	N/A
Oldsmobile	1967-69	350	0-80457S v(A,E) ◆	600	0-80555C v(A) ◆	650
		455	0-80508S v(A,E) ◆	750	N/A	N/A
	1970-74	350,455	0-80450 v(A,E) ◆	600	N/A	N/A
	1975-76	400,455	0-80451 v(A,E) ◆	600	N/A	N/A
	1975-79	350	0-80451 v(A,E) ◆	600	N/A	N/A
Plymouth	1967-69	318	0-80457S v(A,E) ◆	600	N/A	N/A
		383,440	0-80508S v(A,E) ◆	750	N/A	N/A
Pontiac	1967-69	350	0-80457S v(A,E) ◆	600	0-80555C v(A) ◆	650
		400,455 w/o Ram Air	0-80508S v(A,E) ◆	750	N/A	N/A
	1972	307,400	0-80450 v(A,E) ◆	600	N/A	N/A
	1973	400	0-80450 v(A,E) ◆	600	N/A	N/A
	1970-74	350,400,455	0-80450 v(A,E) ◆	600	N/A	N/A
	1975-79	350	0-80451 v(A,E) ◆	600	N/A	N/A

v Vacuum Secondary
m Mechanical Secondary

(A) Not legal for street use in California on vehicles originally equipped with 2-barrel carburetors for which there was no 4-barrel option.

(B) Not legal for sale or use in California on any pollution-controlled motor vehicles.

(E) Adapter P/N 17-6 is required when using a "Square Flange" carburetor on a "Spread Bore" manifold.

(F) It is not recommended or advised that the Holley Street Legal carburetors which are listed for trucks be used on motor homes.

◆ and ◆ See page 223 for symbol explanation. * Not for lean-burn engines or HD trucks.

HOW TO CHOOSE A CARB
STREET CARBURETORS
SUPERCHARGER CARBURETORS
RACE CARBURETORS
MARINE CARBURETORS
CARB SERVICE PARTS & ACCESSORIES
FUEL INJECTION
THROTTLE BODIES
FUEL PUMPS
INTAKE MANIFOLDS
CYLINDER HEADS
SYSTEMAX
ENGINE DRESS-UP
MERCHANDISING
TECHNICAL INFORMATION
INDEX

Supercharger Carburetors

Specifically designed for use on roots style blown engines

Features

- 100% wet-flow tested and calibrated
- Manifold referenced power valve tells the carburetor when to add additional fuel based on the engine's need - eliminating the need to block off the power valve and raise jetting to falsely compensate.

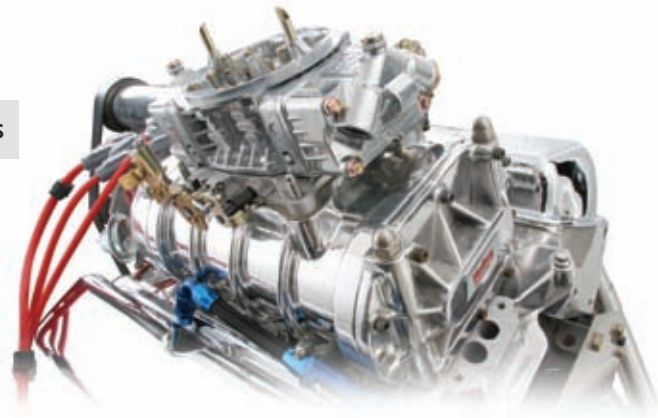

Model 4150™

600 CFM Four Barrel Part # 0-80575S^(B) 3

Features

- Model 4150 HP design
- Chevrolet small block 2x4, 671 blower calibration
- Four-corner idle system
- Dual 50cc accelerator pumps
- Replaceable air bleeds
- Shiny finish
- Mechanical secondary
- Boost referenced power valve
- Throttle lever cut off for clearance on a sideways application



OPTIONAL PARTS & KITS

P/N	DESCRIPTION
36-181	Jet kit
36-184	Accelerator pump tuning kit
7166	Side mount 671 blower carburetor linkage
7093	Side mount 671 blower fuel line kit

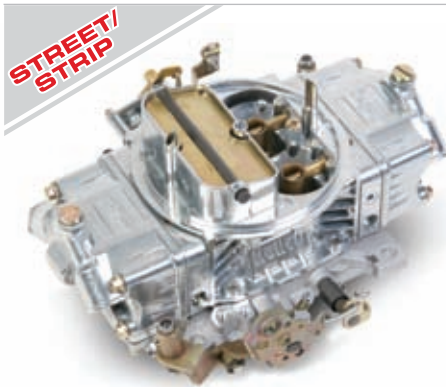

Model 4150™

600 CFM Four Barrel Part # 0-80592S^(B) 3

Features

- Model 4150 with shiny finish
- Chevrolet small block 2 x 4, 671 blower calibration
- Designed for use with superchargers
- Mechanical progressive linkage
- Dual 50cc accelerator pumps
- Manual choke
- Boost referenced power valve
- Throttle lever cut off for clearance on a sideways application

NOTE: May require choke removal on 2 x 4 applications



OPTIONAL PARTS & KITS

P/N	DESCRIPTION
36-181	Jet kit
36-184	Accelerator pump tuning kit
7166	Side mount 671 blower carburetor linkage
7093	Side mount 671 blower fuel line kit



Model 4150™

700 CFM Four Barrel Part # 0-80572S^(B) 3

Features

- Model 4150 with shiny finish
- Chevrolet small block 1x4 140 series supercharger
- Shiny finish
- 50cc secondary pump
- Manual choke
- Mechanical secondary
- Boost referenced power valve



OPTIONAL PARTS & KITS

P/N	DESCRIPTION
36-181	Jet kit
36-184	Accelerator pump tuning kit
36-150	Chrome fuel line

STREET/
STRIP

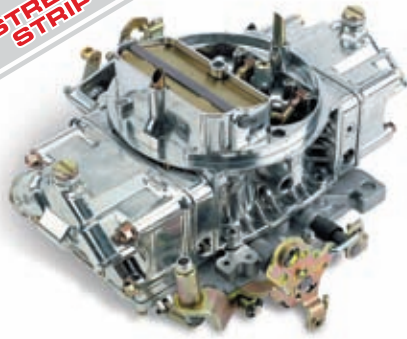

Model 4150™

750 CFM Four Barrel

Part # 0-80573S^(B)

Features

- Model 4150 with shiny finish
- Small block Chevrolet 1x4, 170 series blower calibration
- Four-corner idle system
- Manual choke
- Dual 50cc accelerator pumps
- Mechanical secondary
- Boost referenced power valve



OPTIONAL PARTS & KITS

P/N	DESCRIPTION
36-181	Jet kit
36-184	Accelerator pump tuning kit

STREET/
STRIP



Model 4150™

750 CFM Four Barrel

Part # 0-80576S^(B)

Features

- Model 4150HP design
- Designed for use on the WEIAND® 671 supercharger (big block Chevrolet/Chrysler 392)
- Designed for use on the WEIAND® 871 supercharger (small block Chevrolet/Chrysler 426)
- Four-corner idle system
- Replaceable air bleeds
- Dual 30cc accelerator pumps
- Shiny Finish
- Mechanical secondary
- Boost referenced power valve
- Throttle lever cut off for clearance on a sideways application



OPTIONAL PARTS & KITS

P/N	DESCRIPTION
36-181	Jet kit
36-184	Accelerator pump tuning kit
7166	Side mount 671 blower carburetor linkage
7093	Side mount 671 blower fuel line kit

STREET/
STRIP



Model 4150™

950 CFM Four Barrel

Part # 0-80577S^(B)

Features

- Model 4150HP design
- Big block Chevrolet 2x4, 871 & 1071 blower calibration
- Four-corner idle system
- Screw-in air bleeds
- Dual 30cc accelerator pumps
- Shiny Finish
- Mechanical secondary
- Boost referenced power valve
- Throttle lever cut off for clearance on a sideways application



OPTIONAL PARTS & KITS

P/N	DESCRIPTION
36-181	Jet kit
36-184	Accelerator pump tuning kit
7166	Side mount 671 blower carburetor linkage
7093	Side mount 671 blower fuel line kit

(B) Not legal for sale or use in California on any pollution controlled motor vehicles.

or See page 223 for symbol explanation.

2-bbl Competition Carburetors - Model 2300 HP

Intended for short circle track racing
 Sizes of throttle bore, venturi, booster diameter, throttle plate thickness and throttle shaft diameter have not changed. They comply and are fully consistent with the technical gauging now in use. Venturi casting rings are reamed to legal dimensions, for more consistent air flow



HOW TO CHOOSE A CARB
 STREET CARBURETORS
 SUPERCHARGER CARBURETORS
RACE CARBURETORS
 MARINE CARBURETORS
 CARB SERVICE PARTS & ACCESSORIES
 FUEL INJECTION
 THROTTLE BODIES
 FUEL PUMPS
 INTAKE MANIFOLDS
 CYLINDER HEADS
 SYSTEMAX
 ENGINE DRESS-UP
 MERCHANDISING
 TECHNICAL INFORMATION
 INDEX

- Choke hardware and related provisions are deleted for smoother air flow
- "Straight-type" accelerator pump nozzle design is used to prevent any possibility of fuel pullover & to reduce any chance of rich conditions at high RPM
- Screw-in type air bleeds are used to facilitate tuning
- ID numbers for carburetor and metering block are relocated for ease of viewing.
- HP metering blocks are reinforced & specially designed for optimum atomization
- Metering blocks have installed fuel slosh/vent baffles for superior fuel control during hard acceleration and braking conditions
- 350 CFM factory equipped with changeable emulsion bleeds

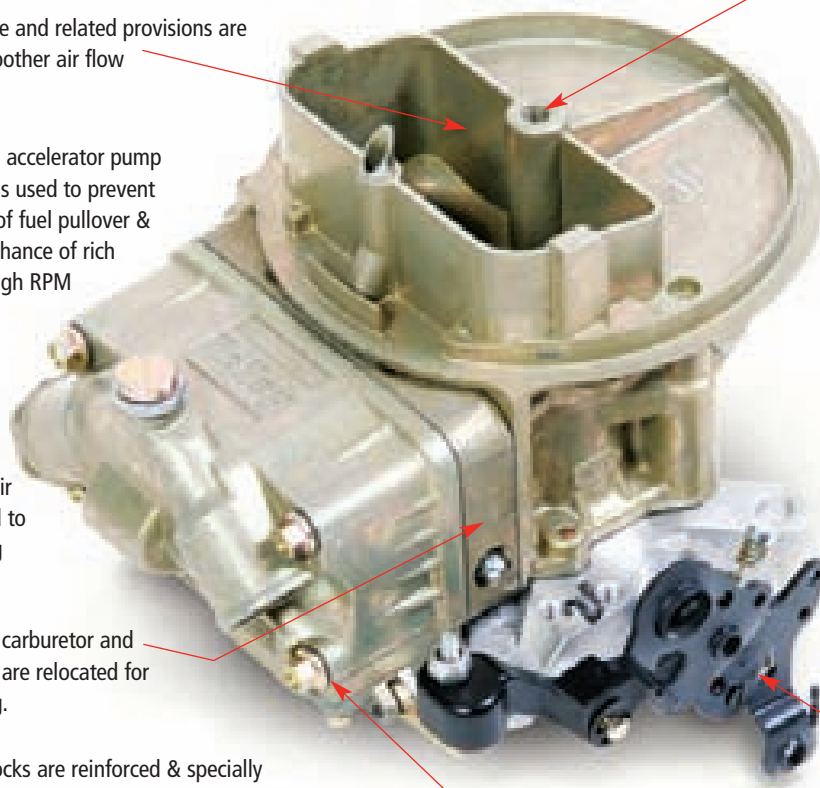

- Air cleaner mounting stud increased from 1/4" to 5/16" diameter for added strength and dependability (500 CFM carburetor)
- Plastic accelerator pump arm is used for more consistent operation
- 30cc accelerator pump GFLT diaphragm is used for durability
- 50cc accelerator pump system has been eliminated from the 500 CFM carburetor. It's been replaced with a user-friendly "off-the-corner" 30cc accelerator pump system
- Welded throttle lever and shaft assembly is used for strength
- Stainless steel throttle plates are used with drilled air bypass hole(s) for smooth idle
- Low profile buttonhead throttle plate screws, secured with Loctite®

Fuel bowl screw gaskets are made of nylon, so they're reusable

100% wet flow tested!

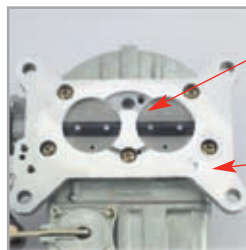

- Power valve blow-out protection eliminates blown power valves
- PCV and other external vacuum tube sources are deleted



Part # 134-276
 Adjustable Metering block for 2-barrel HP models. (Calibrated for 0-80787-1. Can be recalibrated & used on 0-80583-1. Use bleed kit P/N 36-322.)



- A metal cup plug in the throttle body shaft opening eliminates dust, contaminants and unapproved air flow from entering the carburetor

Description	Dichromate Zinc
350 CFM Two Barrel.	Part # 0-80787-1 (B) (3)
500 CFM Two Barrel.	Part # 0-80583-1 (B) (3)

See 0-7448 & 0-4412 2-bbls on page 10.

Loctite® is a registered trademark of The Henkel Corporation.

Legal for use in NASCAR® Whelen All-American Series Late Model class, IMCA Stock Car class, IMCA Southern Sport Mod class, ASA Midwest Tour, and Northwest Pro4 Alliance Series.

Check with your sanctioning body today!



"The Holley 500 CFM HP Carburetor is the best thing that's happened to the NASCAR Whelen All-American Series. Whether you're running a quarter mile bull ring or running the 800 foot long straightaway at Martinsville, the Holley 500 HP carb pulls all the way around"!

Darrell Poe

6 time Regional NASCAR True Value Engine builder of the Year. 1 time National NASCAR True Value Engine Builder of the Year & 2007 UARA Engine Builder of the Year.

HOLLEY CARBS POWER EVERY NASCAR® SPRINT® CUP SERIES TEAM.
Put the same performance under your hood!



Competition Carburetors

Competition fuel curves provide safe and reliable horsepower for high performance race engines



HOW TO CHOOSE A CARB
STREET CARBURETORS
SUPERCHARGER CARBURETORS
RACE CARBURETORS
MARINE CARBURETORS
CARB SERVICE PARTS & ACCESSORIES
FUEL INJECTION
THROTTLE BODIES
FUEL PUMPS
INTAKE MANIFOLDS
CYLINDER HEADS
SYSTEMAX
ENGINE DRESS-UP
MERCHANDISING
TECHNICAL INFORMATION
INDEX

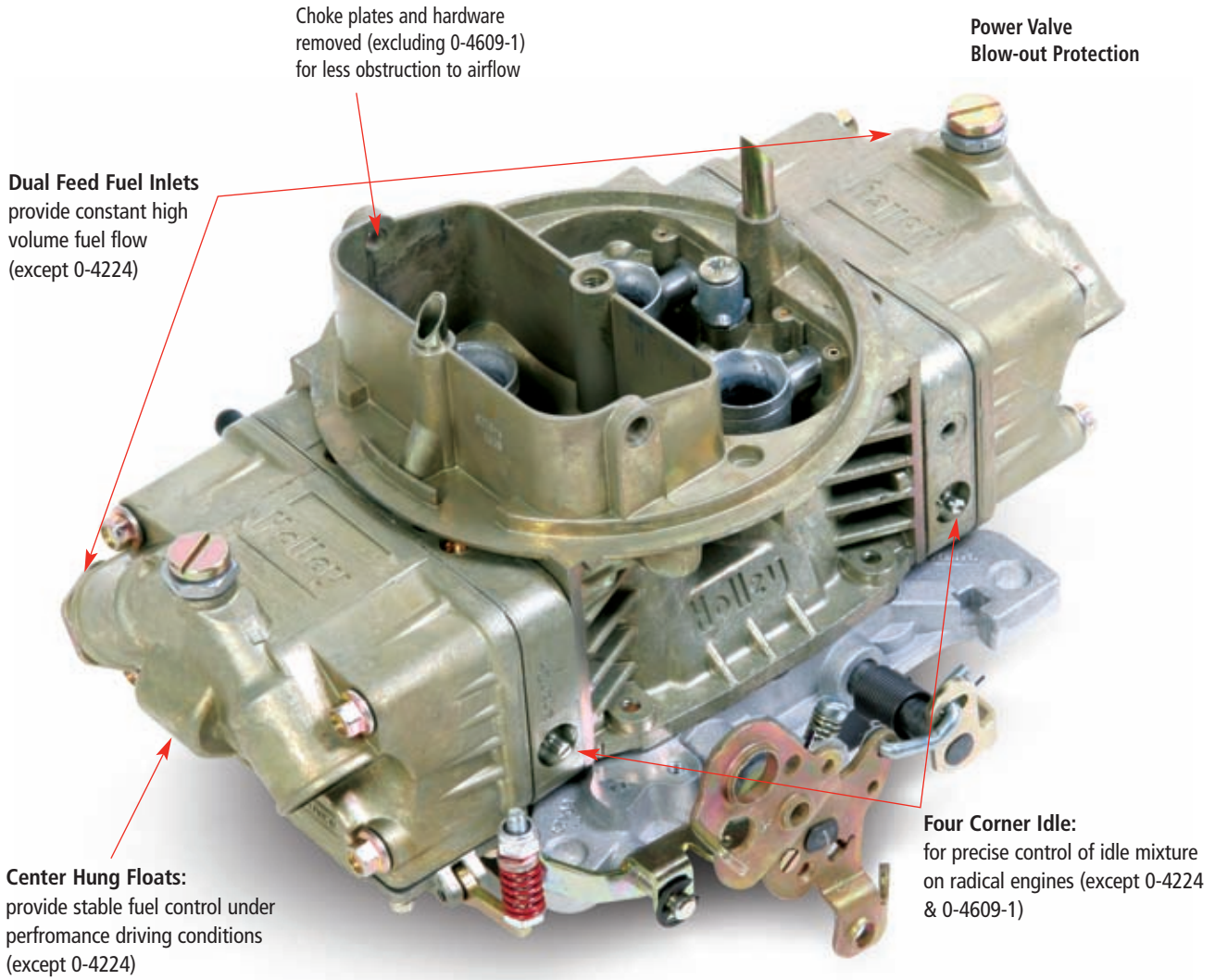

Dual Feed Fuel Inlets provide constant high volume fuel flow (except 0-4224)

Choke plates and hardware removed (excluding 0-4609-1) for less obstruction to airflow

Power Valve Blow-out Protection

Center Hung Floats: provide stable fuel control under performance driving conditions (except 0-4224)

Four Corner Idle: for precise control of idle mixture on radical engines (except 0-4224 & 0-4609-1)

100% wet flow tested!

PART # 0-4609-1 LEGAL FOR NHRA SUPER STOCK & STOCK ELIMINATOR!

Description	Dichromate Zinc
660 CFM Four Barrel 2x4 inline carbs	Part # 0-4224^(B) 3
730 CFM Four Barrel vacuum secondaries	Part # 0-4609-1^(B) 3
750 CFM Four Barrel mechanical secondaries	Part # 0-9379^(B) 3
830 CFM Four Barrel mechanical secondaries	Part # 0-9381^(B) 3
850 CFM Four Barrel mechanical secondaries	Part # 0-9380^(B) 3

Competition Series Carburetors

Use this chart to determine CFM sizing only if you have a very efficient drag race or circle track engine with quality porting, high lift / duration camshaft profile, high compression ratios and efficient intake and exhaust componentry

<i>Cubic Inches</i>	550	0-9381	0-9380	Contact Holley Tech Service for a Recommendation	Contact Holley Tech Service for a Recommendation	Contact Holley Tech Service for a Recommendation	Contact Holley Tech Service for a Recommendation
	525	0-9379	0-9381	0-9380	Contact Holley Tech Service for a Recommendation	Contact Holley Tech Service for a Recommendation	Contact Holley Tech Service for a Recommendation
	500	0-9379	0-9379	0-9381	0-9380	Contact Holley Tech Service for a Recommendation	Contact Holley Tech Service for a Recommendation
	475	0-4609-1	0-9379	0-9381	0-9380	0-9380	Contact Holley Tech Service for a Recommendation
	450	Contact Holley Tech Service for a Recommendation	0-4609-1	0-9379	0-9381	0-9380	Contact Holley Tech Service for a Recommendation
	400	Contact Holley Tech Service for a Recommendation	Contact Holley Tech Service for a Recommendation	0-4609-1	0-9379	0-9379	0-9381
	375	Contact Holley Tech Service for a Recommendation	Contact Holley Tech Service for a Recommendation	Contact Holley Tech Service for a Recommendation	0-4609-1	0-9379	0-9379
	350	Contact Holley Tech Service for a Recommendation	Contact Holley Tech Service for a Recommendation	Contact Holley Tech Service for a Recommendation	Contact Holley Tech Service for a Recommendation	0-4609-1	0-9379
		5000	5500	6000	6500	7000	7500

Max Engine RPM

"Using the Holley 780 CFM carb on my 69 camaro and 1050 CFM Dominator® on my dragster gives me the consistency needed to be competitive!"

Peter Biondo,
Sportsman Racing Legend
NHRA Stock World Champion,
5-Time NHRA World Champion



HOLLEY CARBS POWER EVERY NASCAR® SPRINT® CUP SERIES TEAM. Put the same performance under your hood!



HOW TO CHOOSE A CARB
STREET CARBURETORS
SUPERCHARGER CARBURETORS
RACE CARBURETORS
MARINE CARBURETORS
CARB SERVICE PARTS & ACCESSORIES
FUEL INJECTION
THROTTLE BODIES
FUEL PUMPS
INTAKE MANIFOLDS
CYLINDER HEADS
SYSTEMAX
ENGINE DRESS-UP
MERCHANDISING
TECHNICAL INFORMATION
INDEX

4150 HP™ Carburetors

Performance calibrated and Race Ready out-of-the-box. The standard in race carburetors



Contoured Venturii Inlet:

- For maximum air flow & reduced turbulence (introduced in 1994).
- Symmetrical venturii bores offer balanced air flow for increased horsepower.

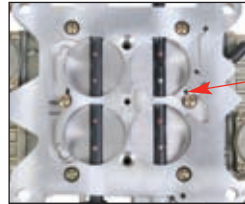

Power Valve Blow-out Protection

High Flow Metering blocks:

Contains strengthening ribs & non-stick reusable metering block & bowl gaskets



Screw-In Air Bleeds:

Changeable air bleeds offer precision tuning capabilities

High Strength Sealing Surfaces:

Precision machined to tight tolerances for unsurpassed sealing

Notched Floats & Jet Extensions:

Continuous fuel delivery under extreme conditions (except 0-80507-1, 0-80535-1, 0-80509-1 & 0-80498-1)

Lightweight Slotted Mixture Screws:

- For precise settings; won't loosen & can't be bumped out of adjustment
- Four corner idle system for precise idle control

Dominator style fuel bowls:

allow plumbing from either side

Stainless Steel Throttle Plates:

- For added strength and corrosion protection
- Buttonhead throttle plate screws with Loctite® fastened threads for more airflow

Spun-In Boosters:

For a perfect tight fit

High flow metering blocks:

calibrated with race only fuel curves

100% wet-flow tested and calibrated



Updated throttle body design, now with added material for additional strength & durability.

**RACE OUT
READY OF THE
BOX**

Description	Dichromate Zinc
390 CFM Four Barrel standard steel throttle plates	Part # 0-80507-1 ^(B) ⚡
600 CFM Four Barrel	Part # 0-80540-1 ^(B) ⚡
650 CFM Four Barrel	Part # 0-80541-1 ^(B) ⚡
750 CFM Four Barrel vacuum secondary	Part # 0-80529-1 ^(B) ⚡
750 CFM Four Barrel	Part # 0-80528-1 ^(B) ⚡
750 CFM Four Barrel methanol	Part # 0-80535-1 ^(B) ⚡
830 CFM Four Barrel down-leg boosters	Part # 0-80509-1 ^(B) ⚡
830 CFM Four Barrel annular boosters	Part # 0-80511-1 ^(B) ⚡
950 CFM Four Barrel	Part # 0-80496-1 ^(B) ⚡
950 CFM Four Barrel methanol	Part # 0-80498-1 ^(B) ⚡
1000 CFM Four Barrel down-leg boosters	Part # 0-80513-1 ^(B) ⚡
1000 CFM Four Barrel annular boosters	Part # 0-80514-1 ^(B) ⚡

All HP, Dominator & Ultra Carburetors

Use this chart to determine CFM sizing only if you have a very efficient drag race or circle track engine with quality porting, high lift / duration camshaft profile, high compression ratios and efficient intake and exhaust componentry

Cubic Inches	625	0-8082-1 / 0-8896-1 0-80586 / 0-9375-1 0-80672	0-7320-1 / 0-80556-1 0-9375-1 / 0-80673	0-80532-1	Contact Holley Tech Service for a Recommendation	Contact Holley Tech Service for a Recommendation	Contact Holley Tech Service for a Recommendation	Contact Holley Tech Service for a Recommendation
	600	0-80513 0-80514	0-8082-1 / 0-8896-1 0-80586 / 0-9375-1 0-80672	0-7320-1 / 0-80556-1 0-9375-1 / 0-80673	0-80532-1	Contact Holley Tech Service for a Recommendation	Contact Holley Tech Service for a Recommendation	Contact Holley Tech Service for a Recommendation
	575	0-80496-1 0-80498-1 0-80676	0-80513 0-80514	0-7320-1 / 0-80556-1 0-9375-1 / 0-80673	0-7320-1 / 0-80556-1 0-9375-1 / 0-80673	0-80532-1	Contact Holley Tech Service for a Recommendation	Contact Holley Tech Service for a Recommendation
	550	0-80496-1 0-80498-1 0-80676	0-80513 0-80514	0-8082-1 / 0-8896-1 0-80586 / 0-9375-1 0-80672	0-7320-1 / 0-80556-1 0-9375-1 / 0-80673	0-7320-1 / 0-80556-1 0-9375-1 / 0-80673	Contact Holley Tech Service for a Recommendation	Contact Holley Tech Service for a Recommendation
	525	0-80509-1 0-80511-1	0-80496-1 0-80498-1 0-80676	0-80513 0-80514	0-8082-1 / 0-8896-1 0-80586 / 0-9375-1 0-80672	0-7320-1 / 0-80556-1 0-9375-1 / 0-80673	0-80532-1	Contact Holley Tech Service for a Recommendation
	500	0-80509-1 0-80511-1	0-80496-1 0-80498-1 0-80676	0-80496-1 0-80498-1 0-80676	0-80513 0-80514	0-8082-1 / 0-8896-1 0-80586 / 0-9375-1 0-80672	0-7320-1 / 0-80556-1 0-9375-1 / 0-80673	0-80532-1
	475	0-80509-1 0-80511-1	0-80496-1 0-80498-1 0-80676	0-80509-1 0-80511-1	0-80496-1 0-80498-1 0-80676	0-8082-1 / 0-8896-1 0-80586 / 0-9375-1 0-80672	0-7320-1 / 0-80556-1 0-9375-1 / 0-80673	0-7320-1 / 0-80556-1 0-9375-1 / 0-80673
	450	0-80528-1 / 0-80529-1 0-80535-1 / 0-80675	0-80509-1 0-80511-1	0-80509-1 0-80511-1	0-80496-1 0-80498-1 0-80676	0-80513 0-80514	0-8082-1 / 0-8896-1 0-80586 / 0-9375-1 0-80672	0-7320-1 / 0-80556-1 0-9375-1 / 0-80673
	400	0-80541-1 0-80674-1	0-80528-1 / 0-80529-1 0-80535-1 / 0-80675	0-80528-1 / 0-80529-1 0-80535-1 / 0-80675	0-80509-1 0-80511-1	0-80509-1 0-80511-1	0-80496-1 0-80498-1 0-80676	0-80513 0-80514
	375	0-80540-1	0-80541-1 0-80674-1	0-80528-1 / 0-80529-1 0-80535-1 / 0-80675	0-80528-1 / 0-80529-1 0-80535-1 / 0-80675	0-80509-1 0-80511-1	0-80509-1 0-80511-1	0-80496-1 0-80498-1 0-80676
	350	0-80540-1	0-80540-1	0-80541-1 0-80674-1	0-80528-1 / 0-80529-1 0-80535-1 / 0-80675	0-80528-1 / 0-80529-1 0-80535-1 / 0-80675	0-80509-1 0-80511-1	0-80509-1 0-80511-1
	325	Contact Holley Tech Service for a Recommendation	0-80540-1	0-80540-1	0-80541-1 0-80674-1	0-80528-1 / 0-80529-1 0-80535-1 / 0-80675	0-80528-1 / 0-80529-1 0-80535-1 / 0-80675	0-80509-1 0-80511-1
	300	Contact Holley Tech Service for a Recommendation	Contact Holley Tech Service for a Recommendation	0-80540-1	0-80540-1	0-80541-1 0-80674-1	0-80528-1 / 0-80529-1 0-80535-1 / 0-80675	0-80528-1 / 0-80529-1 0-80535-1 / 0-80675
		6000	6500	7000	7500	8000	8500	9000

Max Engine RPM



"In the competitive world of NASCAR racing, performance and reliability are critical factors for success. Holley is the only brand of carburetor Richard Childress Racing has used in competition since 1969 and that's why Earnhardt-Childress Racing Engines relies on Holley carburetors exclusively for every engine we build."

Danny Lawrence,
Trackside Manager / Richard Childress Racing.



Photo courtesy: RCR/Harold Hinson Photography

HOLLEY CARBS POWER EVERY NASCAR® SPRINT® CUP SERIES TEAM.

Put the same performance under your hood!



HOW TO CHOOSE A CARB
 STREET CARBURETORS
 SUPERCHARGER CARBURETORS
RACE CARBURETORS
 MARINE CARBURETORS
 CARB SERVICE PARTS & ACCESSORIES
 FUEL INJECTION
 THROTTLE BODIES
 FUEL PUMPS
 INTAKE MANIFOLDS
 CYLINDER HEADS
 SYSTEMAX
 ENGINE DRESS-UP
 MERCHANDISING
 TECHNICAL INFORMATION
 INDEX

Ultra 4150 HP Carburetors



All features of Traditional HP Carbs plus billet metering blocks and base plates for ultimate extreme duty usage.

HOW TO CHOOSE A CARB
STREET CARBURETORS
SUPERCHARGER CARBURETORS
RACE CARBURETORS
MARINE CARBURETORS
CARB SERVICE PARTS & ACCESSORIES
FUEL INJECTION
THROTTLE BODIES
FUEL PUMPS
INTAKE MANIFOLDS
CYLINDER HEADS
SYSTEMAX
ENGINE DRESS-UP
MERCHANDISING
TECHNICAL INFORMATION
INDEX



Anodized Billet Metering Blocks:

- Changeable idle feed restrictors in metering blocks for easier tuning of idle system - no drilling
- Changeable emulsion jets for infinite tunability of metering

Stainless Steel Throttle Plates:

- For added strength and corrosion protection
- Buttonhead throttle plate screws with Loctite® fastened threads for more airflow

Contoured Venturii Inlet:

- For maximum air flow & reduced turbulence (introduced in 1994).
- Symmetrical venturii bores offer balanced air flow for increased horsepower.



Notched Floats & Jet Extensions:

Continuous fuel delivery under extreme conditions (not in all models)

Screw-In Air Bleeds:

Changeable air bleeds offer precision tuning capabilities

High Strength Sealing Surfaces:

Precision machined to tight tolerances for unsurpassed sealing

Popular Holley calibrations:
For race winning out-of-the-box performance

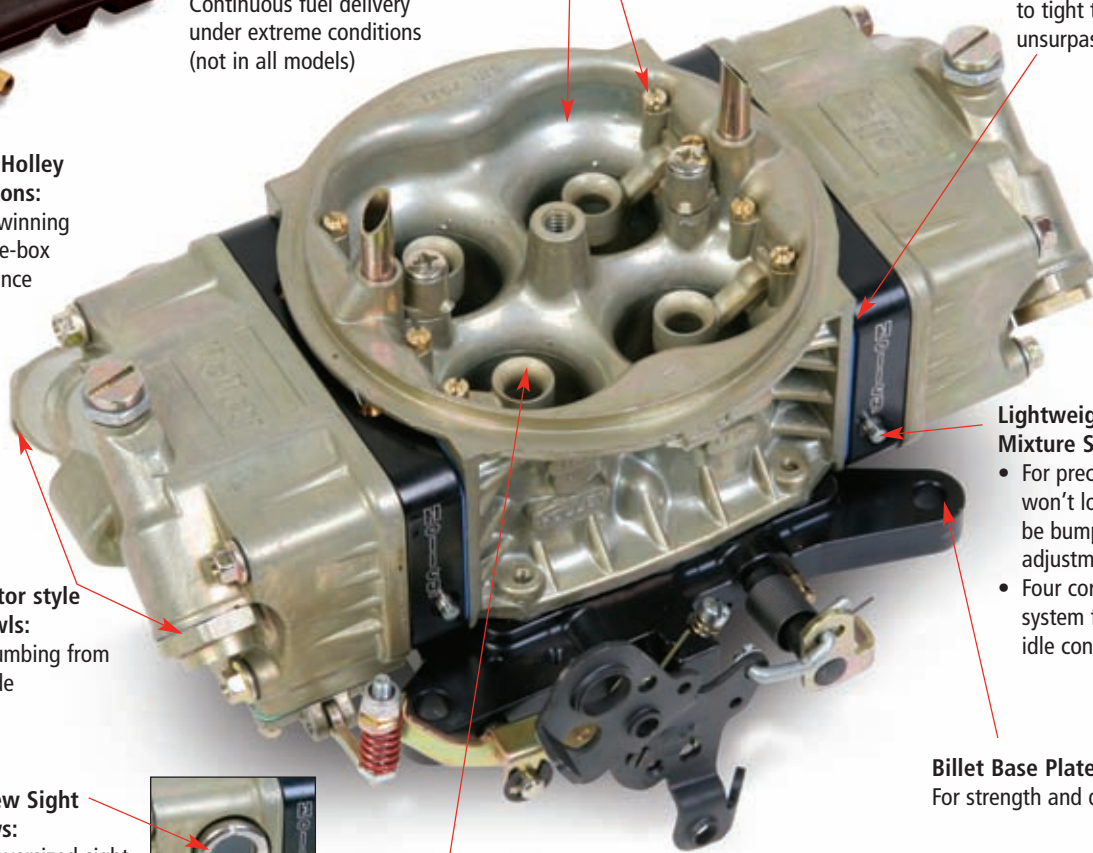

Dominator style fuel bowls:

allow plumbing from either side

Lightweight Slotted Mixture Screws:

- For precise settings; won't loosen & can't be bumped out of adjustment
- Four corner idle system for precise idle control

Easy View Sight Windows:

Built-in oversized sight windows for easy and safe float adjustment



Spun-In Boosters:
For a perfect tight fit (can't fall into engine)

Billet Base Plate
For strength and durability

100% wet flow tested & calibrated

Power Valve Blow-out Protection

Description	Dichromate Zinc
650 CFM Four Barrel	Part # 0-80674^(B) ③
750 CFM Four Barrel	Part # 0-80675^(B) ③
950 CFM Four Barrel	Part # 0-80676^(B) ③

All HP, Dominator & Ultra Carburetors

Use this chart to determine CFM sizing only if you have a very efficient drag race or circle track engine with quality porting, high lift / duration camshaft profile, high compression ratios and efficient intake and exhaust componentry

Cubic Inches

625	0-8082-1 / 0-8896-1 0-80586 / 0-9375-1 0-80672	0-7320-1 / 0-80556-1 0-9375-1 / 0-80673	0-80532-1	Contact Holley Tech Service for a Recommendation	Contact Holley Tech Service for a Recommendation	Contact Holley Tech Service for a Recommendation	Contact Holley Tech Service for a Recommendation
600	0-80513 0-80514	0-8082-1 / 0-8896-1 0-80586 / 0-9375-1 0-80672	0-7320-1 / 0-80556-1 0-9375-1 / 0-80673	0-80532-1	Contact Holley Tech Service for a Recommendation	Contact Holley Tech Service for a Recommendation	Contact Holley Tech Service for a Recommendation
575	0-80496-1 0-80498-1 0-80676	0-80513 0-80514	0-7320-1 / 0-80556-1 0-9375-1 / 0-80673	0-7320-1 / 0-80556-1 0-9375-1 / 0-80673	0-80532-1	Contact Holley Tech Service for a Recommendation	Contact Holley Tech Service for a Recommendation
550	0-80496-1 0-80498-1 0-80676	0-80513 0-80514	0-8082-1 / 0-8896-1 0-80586 / 0-9375-1 0-80672	0-7320-1 / 0-80556-1 0-9375-1 / 0-80673	0-7320-1 / 0-80556-1 0-9375-1 / 0-80673	Contact Holley Tech Service for a Recommendation	Contact Holley Tech Service for a Recommendation
525	0-80509-1 0-80511-1	0-80496-1 0-80498-1 0-80676	0-80513 0-80514	0-8082-1 / 0-8896-1 0-80586 / 0-9375-1 0-80672	0-7320-1 / 0-80556-1 0-9375-1 / 0-80673	0-80532-1	Contact Holley Tech Service for a Recommendation
500	0-80509-1 0-80511-1	0-80496-1 0-80498-1 0-80676	0-80496-1 0-80498-1 0-80676	0-80513 0-80514	0-8082-1 / 0-8896-1 0-80586 / 0-9375-1 0-80672	0-7320-1 / 0-80556-1 0-9375-1 / 0-80673	0-80532-1
475	0-80509-1 0-80511-1	0-80509-1 0-80511-1	0-80496-1 0-80498-1 0-80676	0-80496-1 0-80498-1 0-80676	0-8082-1 / 0-8896-1 0-80586 / 0-9375-1 0-80672	0-7320-1 / 0-80556-1 0-9375-1 / 0-80673	0-7320-1 / 0-80556-1 0-9375-1 / 0-80673
450	0-80528-1 / 0-80529-1 0-80535-1 / 0-80675	0-80509-1 0-80511-1	0-80509-1 0-80511-1	0-80496-1 0-80498-1 0-80676	0-80513 0-80514	0-8082-1 / 0-8896-1 0-80586 / 0-9375-1 0-80672	0-7320-1 / 0-80556-1 0-9375-1 / 0-80673
400	0-80541-1 0-80674-1	0-80528-1 / 0-80529-1 0-80535-1 / 0-80675	0-80528-1 / 0-80529-1 0-80535-1 / 0-80675	0-80509-1 0-80511-1	0-80509-1 0-80511-1	0-80496-1 0-80498-1 0-80676	0-80513 0-80514
375	0-80540-1	0-80541-1 0-80674-1	0-80528-1 / 0-80529-1 0-80535-1 / 0-80675	0-80528-1 / 0-80529-1 0-80535-1 / 0-80675	0-80509-1 0-80511-1	0-80509-1 0-80511-1	0-80496-1 0-80498-1 0-80676
350	0-80540-1	0-80540-1	0-80541-1 0-80674-1	0-80528-1 / 0-80529-1 0-80535-1 / 0-80675	0-80528-1 / 0-80529-1 0-80535-1 / 0-80675	0-80509-1 0-80511-1	0-80509-1 0-80511-1
325	Contact Holley Tech Service for a Recommendation	0-80540-1	0-80540-1	0-80541-1 0-80674-1	0-80528-1 / 0-80529-1 0-80535-1 / 0-80675	0-80528-1 / 0-80529-1 0-80535-1 / 0-80675	0-80509-1 0-80511-1
300	Contact Holley Tech Service for a Recommendation	Contact Holley Tech Service for a Recommendation	0-80540-1	0-80540-1	0-80541-1 0-80674-1	0-80528-1 / 0-80529-1 0-80535-1 / 0-80675	0-80528-1 / 0-80529-1 0-80535-1 / 0-80675
	6000	6500	7000	7500	8000	8500	9000

Max Engine RPM

"Holley carbs have been making power since the 1950s, and they proved it again when I used them to break five different land speed records in one week at Bonneville in 2007."

David Freiburger,
7 Years Editor-in-Chief Hot Rod Magazine
& Host of Carjunktiv.com.



HOLLEY CARBS POWER EVERY NASCAR® SPRINT® CUP SERIES TEAM.

Put the same performance under your hood!



HOW TO CHOOSE A CARB
STREET CARBURETORS
SUPERCHARGER CARBURETORS
RACE CARBURETORS
MARINE CARBURETORS
CARB SERVICE PARTS & ACCESSORIES
FUEL INJECTION
THROTTLE BODIES
FUEL PUMPS
INTAKE MANIFOLDS
CYLINDER HEADS
SYSTEMAX
ENGINE DRESS-UP
MERCHANDISING
TECHNICAL INFORMATION
INDEX

4500 Dominator HP™ Carburetors



The ultimate high performance racing carburetor for big inch high horsepower engines. The world famous Holley Dominator!

Contoured Venturii Inlet:

- For maximum air flow & reduced turbulence
- Symmetrical venturii bores offer balanced airflow for increased horsepower

Aluminum Throttle Plates:

- For corrosion resistance
- Button head screws for increased air flow

High Flow Needle & Seat Assemblies:

Keep balanced fuel levels for no starvation

Screw-In Air Bleeds:

Changeable air bleeds offer precision tuning capabilities

High Strength Sealing Surfaces:
Precision machined to tight tolerances for unsurpassed sealing

Pinned Boosters:

- Can't fall into engine
- Annular booster design delivers excellent vacuum signal for crisp throttle response & early fuel atomization

Dominator fuel bowls:
allow plumbing from either side

High Flow Metering blocks:

- Contain strengthening ribs & non-stick reusable metering block & bowl gaskets
- Calibrated for race only

Lightweight Slotted Mixture Screws:

- For precise settings; won't loosen & can't be bumped out of adjustment
- Four corner idle system for precise idle control

100% wet flow tested & calibrated

Dual 50cc Accelerator Pumps:

Provide the perfect amount of fuel through the transition from idle to full throttle



Notched Floats & Jet Extensions:

- Continuous fuel delivery under extreme conditions (except 0-80586-1)

Description	Dichromate Zinc
2-CIRCUIT DOMINATORS (1 X 4 CARBURETORS SET-UPS)	
750 CFM Four Barrel	Part # 0-80186-1 ^(B) 3
1050 CFM Four Barrel	Part # 0-8082-1 ^(B) 3
1150 CFM Four Barrel	Part # 0-7320-1 ^(B) 3
3-CIRCUIT DOMINATORS (1 X 4 CARBURETORS SET-UPS)	
1050 CFM Four Barrel	Part # 0-8896-1 ^(B) 3
1050 CFM Four Barrel methanol.	Part # 0-80586 ^(B) 3
1150 CFM Four Barrel	Part # 0-80556-1 ^(B) 3
1250 CFM Four Barrel	Part # 0-80532-1 ^(B) 3
3-CIRCUIT DOMINATORS (2 X 4 CARBURETORS SET-UPS)	
1050 CFM Four Barrel	Part # 0-9375-1 ^(B) 3
1150 CFM Four Barrel	Part # 0-9377-1 ^(B) 3

NOTE: 3rd circuit adds another level of transition thus requiring less pump shot

All HP, Dominator & Ultra Carburetors

Use this chart to determine CFM sizing only if you have a very efficient drag race or circle track engine with quality porting, high lift / duration camshaft profile, high compression ratios and efficient intake and exhaust componentry

Cubic Inches	625	0-8082-1 / 0-8896-1 0-80586 / 0-9375-1 0-80672	0-7320-1 / 0-80556-1 0-9375-1 / 0-80673	0-80532-1	Contact Holley Tech Service for a Recommendation	Contact Holley Tech Service for a Recommendation	Contact Holley Tech Service for a Recommendation	Contact Holley Tech Service for a Recommendation	
	600	0-80513 0-80514	0-8082-1 / 0-8896-1 0-80586 / 0-9375-1 0-80672	0-7320-1 / 0-80556-1 0-9375-1 / 0-80673	0-80532-1	Contact Holley Tech Service for a Recommendation	Contact Holley Tech Service for a Recommendation	Contact Holley Tech Service for a Recommendation	
	575	0-80496-1 0-80498-1 0-80676	0-80513 0-80514	0-7320-1 / 0-80556-1 0-9375-1 / 0-80673	0-7320-1 / 0-80556-1 0-9375-1 / 0-80673	0-80532-1	Contact Holley Tech Service for a Recommendation	Contact Holley Tech Service for a Recommendation	
	550	0-80496-1 0-80498-1 0-80676	0-80513 0-80514	0-8082-1 / 0-8896-1 0-80586 / 0-9375-1 0-80672	0-7320-1 / 0-80556-1 0-9375-1 / 0-80673	0-7320-1 / 0-80556-1 0-9375-1 / 0-80673	Contact Holley Tech Service for a Recommendation	Contact Holley Tech Service for a Recommendation	
	525	0-80509-1 0-80511-1	0-80496-1 0-80498-1 0-80676	0-80513 0-80514	0-8082-1 / 0-8896-1 0-80586 / 0-9375-1 0-80672	0-7320-1 / 0-80556-1 0-9375-1 / 0-80673	0-80532-1	Contact Holley Tech Service for a Recommendation	
	500	0-80509-1 0-80511-1	0-80496-1 0-80498-1 0-80676	0-80496-1 0-80498-1 0-80676	0-80513 0-80514	0-8082-1 / 0-8896-1 0-80586 / 0-9375-1 0-80672	0-7320-1 / 0-80556-1 0-9375-1 / 0-80673	0-80532-1	
	475	0-80509-1 0-80511-1	0-80496-1 0-80498-1 0-80676	0-80509-1 0-80511-1	0-80496-1 0-80498-1 0-80676	0-8082-1 / 0-8896-1 0-80586 / 0-9375-1 0-80672	0-7320-1 / 0-80556-1 0-9375-1 / 0-80673	0-7320-1 / 0-80556-1 0-9375-1 / 0-80673	
	450	0-80528-1 / 0-80529-1 0-80535-1 / 0-80675	0-80509-1 0-80511-1	0-80509-1 0-80511-1	0-80496-1 0-80498-1 0-80676	0-80513 0-80514	0-8082-1 / 0-8896-1 0-80586 / 0-9375-1 0-80672	0-7320-1 / 0-80556-1 0-9375-1 / 0-80673	
	400	0-80541-1 0-80674-1	0-80528-1 / 0-80529-1 0-80535-1 / 0-80675	0-80528-1 / 0-80529-1 0-80535-1 / 0-80675	0-80509-1 0-80511-1	0-80509-1 0-80511-1	0-80496-1 0-80498-1 0-80676	0-80513 0-80514	
	375	0-80540-1	0-80541-1 0-80674-1	0-80528-1 / 0-80529-1 0-80535-1 / 0-80675	0-80528-1 / 0-80529-1 0-80535-1 / 0-80675	0-80509-1 0-80511-1	0-80509-1 0-80511-1	0-80496-1 0-80498-1 0-80676	
	350	0-80540-1	0-80540-1	0-80541-1 0-80674-1	0-80528-1 / 0-80529-1 0-80535-1 / 0-80675	0-80528-1 / 0-80529-1 0-80535-1 / 0-80675	0-80509-1 0-80511-1	0-80509-1 0-80511-1	
	325	Contact Holley Tech Service for a Recommendation	0-80540-1	0-80540-1	0-80541-1 0-80674-1	0-80528-1 / 0-80529-1 0-80535-1 / 0-80675	0-80528-1 / 0-80529-1 0-80535-1 / 0-80675	0-80509-1 0-80511-1	
	300	Contact Holley Tech Service for a Recommendation	Contact Holley Tech Service for a Recommendation	0-80540-1	0-80540-1	0-80541-1 0-80674-1	0-80528-1 / 0-80529-1 0-80535-1 / 0-80675	0-80528-1 / 0-80529-1 0-80535-1 / 0-80675	
			6000	6500	7000	7500	8000	8500	9000

Max Engine RPM

“Holley carbs are the standard of the industry. They are the only carbs I trust to use”.

Warren Johnson,
1st Pro Stock to break 200MPH Barrier
and NHRA Pro Stock's All Time Winning Driver



HOLLEY CARBS POWER EVERY NASCAR® SPRINT® CUP SERIES TEAM.

Put the same performance under your hood!



HOW TO CHOOSE A CARB
STREET CARBURETORS
SUPERCHARGER CARBURETORS
RACE CARBURETORS
MARINE CARBURETORS
CARB SERVICE PARTS & ACCESSORIES
FUEL INJECTION
THROTTLE BODIES
FUEL PUMPS
INTAKE MANIFOLDS
CYLINDER HEADS
SYSTEMAX
ENGINE DRESS-UP
MERCHANDISING
TECHNICAL INFORMATION
INDEX

ULTRA Dominator® HP Carburetors



All features of traditional Dominator® HP carbs plus adjustable billet metering blocks for ultimate extreme duty usage and expanded tuning!

HOW TO CHOOSE A CARB
STREET CARBURETORS
SUPERCHARGER CARBURETORS
RACE CARBURETORS
MARINE CARBURETORS
CARB SERVICE PARTS & ACCESSORIES
FUEL INJECTION
THROTTLE BODIES
FUEL PUMPS
INTAKE MANIFOLDS
CYLINDER HEADS
SYSTEMAX
ENGINE DRESS-UP
MERCHANDISING
TECHNICAL INFORMATION
INDEX



Anodized Billet Metering Blocks:

- Changeable idle feed restrictors in metering blocks for easier tuning of idle system - no drilling
- Changeable emulsion jets for infinite tunability of metering

Contoured Venturii Inlet:

- For maximum air flow & reduced turbulence
- Symmetrical venturii bores offer balanced airflow for increased horsepower

Pinned Boosters:

- Annular booster design delivers excellent vacuum signal for crisp throttle response & early fuel atomization

Popular Holley calibrations:
For race winning out-of-the-box performance

Screw-In Air Bleeds:
Changeable air bleeds offer precision tuning capabilities

Dominator fuel bowls:
allow plumbing from either side

Easy View Sight Windows:
Built-in oversized sight windows for easy and safe float adjustment

Dual 50cc Accelerator Pumps:
Provide the perfect amount of fuel through the transition from idle to full throttle

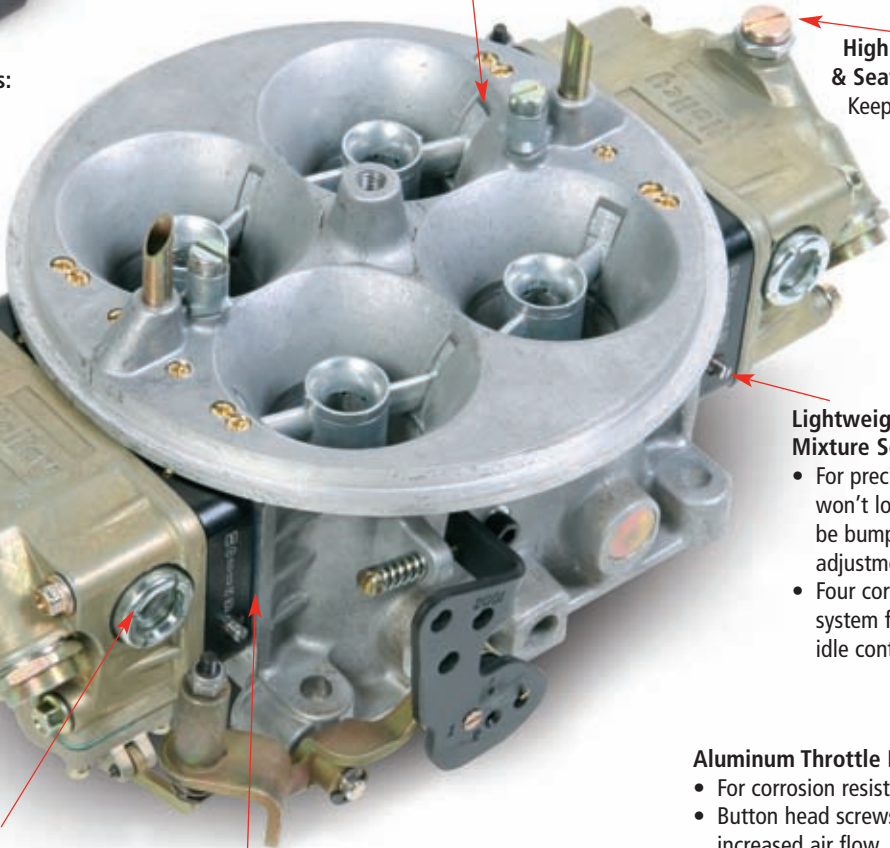

High Flow Needle & Seat Assemblies:
Keep balanced fuel levels for no starvation

Lightweight Slotted Mixture Screws:

- For precise settings; won't loosen & can't be bumped out of adjustment
- Four corner idle system for precise idle control

Aluminum Throttle Plates:

- For corrosion resistance
- Button head screws for increased air flow

High Strength Sealing Surfaces:
Precision machined to tight tolerances for unsurpassed sealing

100% wet flow tested & calibrated



Notched Floats & Jet Extensions:

- Continuous fuel delivery under extreme conditions

Description	Dichromate Zinc
1050 CFM Four Barrel	Part # 0-80672^(B) ⚡
1150 CFM Four Barrel	Part # 0-80673^(B) ⚡

All HP, Dominator & Ultra Carburetors

Use this chart to determine CFM sizing only if you have a very efficient drag race or circle track engine with quality porting, high lift / duration camshaft profile, high compression ratios and efficient intake and exhaust componentry

Cubic Inches	625	0-8082-1 / 0-8896-1 0-80586 / 0-9375-1 0-80672	0-7320-1 / 0-80556-1 0-9375-1 / 0-80673	0-80532-1	Contact Holley Tech Service for a Recommendation	Contact Holley Tech Service for a Recommendation	Contact Holley Tech Service for a Recommendation	Contact Holley Tech Service for a Recommendation
	600	0-80513 0-80514	0-8082-1 / 0-8896-1 0-80586 / 0-9375-1 0-80672	0-7320-1 / 0-80556-1 0-9375-1 / 0-80673	0-80532-1	Contact Holley Tech Service for a Recommendation	Contact Holley Tech Service for a Recommendation	Contact Holley Tech Service for a Recommendation
	575	0-80496-1 0-80498-1 0-80676	0-80513 0-80514	0-7320-1 / 0-80556-1 0-9375-1 / 0-80673	0-7320-1 / 0-80556-1 0-9375-1 / 0-80673	0-80532-1	Contact Holley Tech Service for a Recommendation	Contact Holley Tech Service for a Recommendation
	550	0-80496-1 0-80498-1 0-80676	0-80513 0-80514	0-8082-1 / 0-8896-1 0-80586 / 0-9375-1 0-80672	0-7320-1 / 0-80556-1 0-9375-1 / 0-80673	0-7320-1 / 0-80556-1 0-9375-1 / 0-80673	Contact Holley Tech Service for a Recommendation	Contact Holley Tech Service for a Recommendation
	525	0-80509-1 0-80511-1	0-80496-1 0-80498-1 0-80676	0-80513 0-80514	0-8082-1 / 0-8896-1 0-80586 / 0-9375-1 0-80672	0-7320-1 / 0-80556-1 0-9375-1 / 0-80673	0-80532-1	Contact Holley Tech Service for a Recommendation
	500	0-80509-1 0-80511-1	0-80496-1 0-80498-1 0-80676	0-80496-1 0-80498-1 0-80676	0-80513 0-80514	0-8082-1 / 0-8896-1 0-80586 / 0-9375-1 0-80672	0-7320-1 / 0-80556-1 0-9375-1 / 0-80673	0-80532-1
	475	0-80509-1 0-80511-1	0-80509-1 0-80511-1	0-80496-1 0-80498-1 0-80676	0-80496-1 0-80498-1 0-80676	0-8082-1 / 0-8896-1 0-80586 / 0-9375-1 0-80672	0-7320-1 / 0-80556-1 0-9375-1 / 0-80673	0-7320-1 / 0-80556-1 0-9375-1 / 0-80673
	450	0-80528-1 / 0-80529-1 0-80535-1 / 0-80675	0-80509-1 0-80511-1	0-80509-1 0-80511-1	0-80496-1 0-80498-1 0-80676	0-80513 0-80514	0-8082-1 / 0-8896-1 0-80586 / 0-9375-1 0-80672	0-7320-1 / 0-80556-1 0-9375-1 / 0-80673
	400	0-80541-1 0-80674-1	0-80528-1 / 0-80529-1 0-80535-1 / 0-80675	0-80528-1 / 0-80529-1 0-80535-1 / 0-80675	0-80509-1 0-80511-1	0-80509-1 0-80511-1	0-80496-1 0-80498-1 0-80676	0-80513 0-80514
	375	0-80540-1	0-80541-1 0-80674-1	0-80528-1 / 0-80529-1 0-80535-1 / 0-80675	0-80528-1 / 0-80529-1 0-80535-1 / 0-80675	0-80509-1 0-80511-1	0-80509-1 0-80511-1	0-80496-1 0-80498-1 0-80676
	350	0-80540-1	0-80540-1	0-80541-1 0-80674-1	0-80528-1 / 0-80529-1 0-80535-1 / 0-80675	0-80528-1 / 0-80529-1 0-80535-1 / 0-80675	0-80509-1 0-80511-1	0-80509-1 0-80511-1
	325	Contact Holley Tech Service for a Recommendation	0-80540-1	0-80540-1	0-80541-1 0-80674-1	0-80528-1 / 0-80529-1 0-80535-1 / 0-80675	0-80528-1 / 0-80529-1 0-80535-1 / 0-80675	0-80509-1 0-80511-1
	300	Contact Holley Tech Service for a Recommendation	Contact Holley Tech Service for a Recommendation	0-80540-1	0-80540-1	0-80541-1 0-80674-1	0-80528-1 / 0-80529-1 0-80535-1 / 0-80675	0-80528-1 / 0-80529-1 0-80535-1 / 0-80675
			6000	6500	7000	7500	8000	8500

Max Engine RPM

"I have used Holley carbs on both my Super Rod car and my Top Dragster and have ran 6.60 at over 203 MPH with one stage of nitrous consistently. They have performed very well all year long at the track with no maintenance required."

Steve Furr,
IHRA Super Rod World Champion



HOLLEY CARBS POWER EVERY NASCAR® SPRINT® CUP SERIES TEAM.

Put the same performance under your hood!



HOW TO CHOOSE A CARB
 STREET CARBURETORS
 SUPERCHARGER CARBURETORS
RACE CARBURETORS
 MARINE CARBURETORS
 CARB SERVICE PARTS & ACCESSORIES
 FUEL INJECTION
 THROTTLE BODIES
 FUEL PUMPS
 INTAKE MANIFOLDS
 CYLINDER HEADS
 SYSTEMAX
 ENGINE DRESS-UP
 MERCHANDISING
 TECHNICAL INFORMATION
 INDEX

HOW TO CHOOSE A CARB
STREET CARBURETORS
SUPERCHARGER CARBURETORS
RACE CARBURETORS
MARINE CARBURETORS
CARB SERVICE PARTS & ACCESSORIES
FUEL INJECTION
THROTTLE BODIES
FUEL PUMPS
INTAKE MANIFOLDS
CYLINDER HEADS
SYSTEMAX
ENGINE DRESS-UP
MERCHANDISING
TECHNICAL INFORMATION
INDEX

RACE



Model 2300 HP™

350 CFM Two Barrel

Part # 0-80787-1^(B) 3



Features

- HP metering block with changeable emulsion bleeds for infinite tuning
- Choke deleted for improved airflow
- 30cc accelerator pump
- Welded Throttle lever
- Screw In air bleeds
- Straight boosters
- Venturii size 1.187
- Throttle bore 1.500
- Stainless steel throttle plates
- See page 36 for more details & applications

OPTIONAL PARTS & KITS

P/N	DESCRIPTION
137-276	metering block
36-322	Tuning kit

**STREET/
RACE**



Model 2300™

350 CFM Two Barrel

Part # 0-7448^(B) 3



Features

- Manual choke
- 30cc accelerator pump
- 1 timed (spark) port & 1 PCV port
- Intended as stock performance replacement for 2-bbl street applications. Also mandated carbs for some oval track racing sanctioning bodies.
- Ford A/T kickdown
- Does not work with A.O.D. transmissions
- Installation & Tuning DVD included
- See pages 10 & 11 for more details & applications

OPTIONAL PARTS & KITS

P/N	DESCRIPTION
36-181	Jet kit
20-12	Pump cam assortment kit
36-184	Accelerator pump tuning kit
20-91	Ford automatic transmission bracket kit

RACE

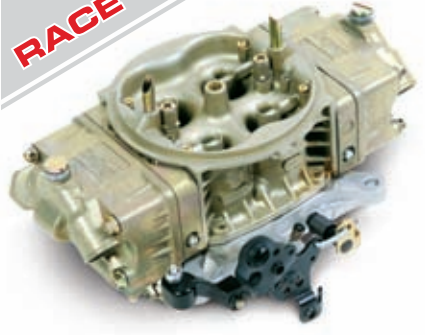

Model 4150 HP™

390 CFM Four Barrel

Part # 0-80507-1^(B) 3



Features

- NASCAR Approved
- Designed for use on circle track engines
- Progressive Secondaries
- Dual 30cc accelerator pumps
- Calibrated for gasoline
- Dual fuel inlets
- 4 corner idle
- Screw in air bleeds
- Straight boosters
- Venturii size 1.062
- Throttle bore 1.437
- Steel throttle plates
- See pages 40 & 41 for more details & applications

RACE



Model 2300™

500 CFM Two Barrel

Part # 0-80583-1^(B) 3



Features

- HP metering block
- Choke deleted for improved airflow
- 30cc accelerator pump
- Welded Throttle lever
- Screw In air bleeds
- Down Leg Boosters
- Venturii Size 1.375
- Throttle bore 1.687
- Stainless Steel throttle plates
- See page 36 for more details & applications

OPTIONAL PARTS & KITS

P/N	DESCRIPTION
134-280	Replacement metering block
112-111	Replacement throttle body assembly
36-181	Jet kit
36-184	Accelerator pump tuning kit
20-12	Pump cam assortment kit

STREET/
RACE



Model 2300™

500 CFM Two Barrel

Part # 0-4412C^(B) 3 - Dichromate Finish

Part # 0-4412S^(B) 3 - Shiny Finish



Features

- Manual choke
- 50cc accelerator pump
- 1 timed (spark) port, 1 full vacuum, & 1 PCV port
- Intended as stock performance replacement for 2-bbl street applications. Also mandated carbs for some oval track racing sanctioning bodies.
- Ford A/T kickdown
- Does not work with A.O.D. transmissions
- Installation & Tuning DVD included
- See pages 10 & 11 for more details & applications

OPTIONAL PARTS & KITS

P/N	DESCRIPTION
36-181	Jet kit
20-91	Ford automatic transmission bracket kit

RACE



Model 4150 HP™

600 CFM Four Barrel

Part # 0-80540-1^(B) 3



Features

- Designed for use on race engines
- Includes notched float and jet extensions
- Progressive Secondaries
- Dual 30cc accelerator pumps
- Calibrated for gasoline
- Dual fuel inlets
- 4 corner idle
- Screw in air bleeds
- Straight boosters
- Venturii Size 1.229
- Throttle bore 1.563
- Stainless steel throttle plates
- See pages 40 & 41 for more details & applications

STREET/
RACE



Model 4150™

600 CFM Four Barrel

Part # 0-4776C^(B) 3 - Dichromate finish

Part # 0-4776S^(B) 3 - Shiny finish



Features

- Mechanical secondaries
- Dual accelerator pumps (Double Pumper®)
- Manual choke
- Two corner idle
- Dual feed fuel inlet
- 1 timed (spark) port, 1 full vacuum, and 1 PCV port
- Intended for lightweight vehicles w/ manual trans or automatics with high stall & low gearing
- Installation & Tuning DVD included
- See pages 18 & 19 for more details & applications

OPTIONAL PARTS & KITS

P/N	DESCRIPTION
20-88	Throttle cable/return spring bracket kit
36-181	Jet kit
20-12	Pump cam assortment kit
36-184	Accelerator pump tuning kit
20-122	Pro series secondary linkage
36-182	Tuning calibration kit
26-137	Secondary adjusting lever kit
34-39	Billet adjustable fuel log
20-124	Universal install kit
20-121	700R-4 kickdown throttle arm
20-95	GM A.O.D. transmission bracket kit

RACE



Model 4150 HP™

650 CFM Four Barrel

Part # 0-80541-1^(B) 3



Features

- Designed for use on race engines
- Includes notched float and jet extensions
- Recommended for GM Performance Parts circle track crate engines
- Progressive Secondaries
- Dual 30cc accelerator pumps
- Calibrated for gasoline
- Dual fuel inlets
- 4 corner idle
- Screw in air bleeds
- Straight boosters
- Venturii Size 1.25
- Throttle bore 1.688
- Stainless steel throttle plates
- See pages 40 & 41 for more details & applications

RACE



Model 4150 Ultra HP™

650 CFM Four Barrel

Part # 0-80674^(B) 3



Features

- Designed for use on race engines
- Billet Aluminum metering blocks with changeable emulsion bleeds and idle feed restrictors
- Billet Aluminum base plate for strength and durability
- Large glass sight windows for quick fuel level adjustments
- Includes notched float and jet extensions
- Progressive Secondaries
- Dual 30cc accelerator pumps
- Calibrated for gasoline
- Dual fuel inlets
- 4 corner idle
- Screw in air bleeds
- Straight boosters
- Venturii Size 1.25
- Throttle bore 1.688
- Stainless Steel throttle plates
- See page 42 & 43 for more details & applications

**STREET/
RACE**



Model 4150™

650 CFM Four Barrel

Part # 0-4777C^(B) 3 - Dichromate finish

Part # 0-4777S^(B) 3 - Shiny finish



Features

- Mechanical secondaries
- Dual accelerator pumps (Double Pumper®)
- Manual choke
- Two corner idle
- Dual feed fuel inlet
- 1 timed (spark) port, 1 full vacuum, and 1 PCV port
- Intended for lightweight vehicles w/ manual trans or automatics with high stall & low gearing
- Installation & Tuning DVD included
- See pages 18 & 19 for more details & applications

OPTIONAL PARTS & KITS

P/N	DESCRIPTION
20-88	GM Throttle cable/return spring bracket kit
36-181	Jet kit
20-12	Pump cam assortment kit
36-184	Accelerator pump tuning kit
20-122	Pro series secondary linkage
36-182	Tuning calibration kit
26-137	Secondary adjusting lever kit
34-39	Billet adjustable fuel log
20-124	Universal install kit
34-150	Chrome fuel line

**STREET/
RACE**

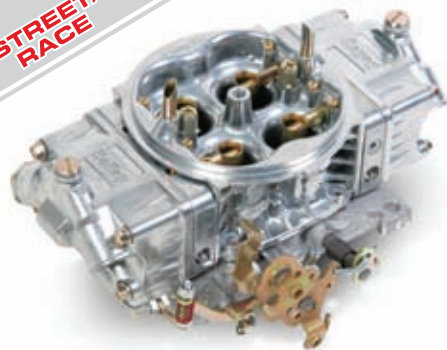

Model 4150 HP™

650 CFM Four Barrel

Part # 0-82651^(B) 3



Features

- Mechanical secondaries
- Dual accelerator pumps
- No choke
- Choke horn removed for increased airflow
- Four corner idle for precise idle control
- Dual feed fuel inlet
- 1 timed (spark) port, 1 full vacuum, and 1 PCV port
- Intended for lightweight vehicles w/ manual trans or automatics with high stall & low gearing. Street/race calibration for outstanding throttle response & drivability
- Installation & Tuning DVD included
- See pages 20 & 21 for more details & applications

OPTIONAL PARTS & KITS

P/N	DESCRIPTION
20-88	GM Throttle cable/return spring bracket kit
36-181	Jet kit
36-240	Air bleed kit
20-12	Pump cam assortment kit
36-184	Accelerator pump tuning kit
20-122	Pro series secondary linkage
36-182	Tuning calibration kit
26-137	Secondary adjusting lever kit
34-39	Billet adjustable fuel log
20-124	Universal install kit
34-150	Chrome fuel line

RACE



Model 4160™

660 CFM Four Barrel

Part # 0-4224^(B) 3



Features

- Model 4160
- 2x4 intake manifold
- 1:1 mechanical linkage
- 50cc center discharge pump
- Side hung float bowls
- Single fuel inlet
- See pages 38 & 39 for more details & applications
- Center squirter

OPTIONAL PARTS & KITS

P/N	Description
1049-949	Air Cleaner Bail
121-325	Accelerator Pump Nozzle

**STREET/
RACE**



Model 4150™

700 CFM Four Barrel

Part # 0-4778C^(B) - Dichromate finish

Part # 0-4778S^(B) - Shiny finish



Features

- Mechanical secondaries
- Dual accelerator pumps
- Manual choke
- Two corner idle
- Dual feed fuel inlet
- 1 timed (spark) port, 1 full vacuum, and 1 PCV port
- Intended for lightweight vehicles w/ manual trans or automatics with high stall & low gearing
- Installation & Tuning DVD included
- See pages 18 & 19 for more details & applications

OPTIONAL PARTS & KITS

P/N	DESCRIPTION
20-88	GM Throttle cable/return spring bracket kit
36-181	Jet kit
20-12	Pump cam assortment kit
36-184	Accelerator pump tuning kit
20-122	Pro series secondary linkage
36-182	Tuning calibration kit
26-137	Secondary adjusting lever kit
34-39	Billet adjustable fuel log
20-124	Universal install kit
34-150	Chrome fuel line

RACE



Model 4150™

730 CFM Four Barrel

Part # 0-4609-1^(B)



Features

- Legal for NHRA Super Stock and Stock Eliminator
- Vacuum secondaries
- Power valve blow-out protection
- Center hung bowls
- Choke plate installed - no linkage
- See pages 38 & 39 for more details & applications

OPTIONAL PARTS & KITS

P/N	DESCRIPTION
36-181	Jet kit
20-12	Pump cam assortment kit
36-184	Accelerator pump tuning kit
20-13	Secondary diaphragm spring kit
20-59	Quick change secondary spring kit
36-182	Tuning calibration kit
34-39	Billet adjustable fuel log
20-124	Universal install kit

RACE



Model 4150™

750 CFM Four Barrel

Part # 0-9379^(B)



Features

- No choke hardware
- Double 30cc accelerator pumps
- Dual feed fuel inlet
- Four-corner idle system
- Mechanical secondaries
- Annular boosters
- See page 38 & 39 for more details & applications

OPTIONAL PARTS & KITS

P/N	DESCRIPTION
36-181	Jet kit
20-12	Pump cam assortment kit
36-184	Accelerator pump tuning kit
20-122	Pro series secondary linkage
36-182	Tuning calibration kit
26-137	Secondary adjusting lever kit
34-39	Billet adjustable fuel log
20-124	Universal install kit

RACE



Model 4150 HP™

750 CFM Four Barrel

Part # 0-80529-1^(B)



Features

- Designed for use on race engines
- Includes notched float and jet extensions
- Vacuum Secondaries with quick change spring cover
- 3 vacuum ports (1 timed, 2 full)
- 30cc accelerator pump
- Calibrated for gasoline
- Dual fuel inlets
- 4 corner idle
- Screw in air bleeds
- Double step, down leg boosters
- Venturii Size 1.376
- Throttle bore 1.687
- Stainless steel throttle plates
- See pages 40 & 41 for more details & applications

(B) Not legal for sale or use in California on any pollution controlled motor vehicles.

See page 223 for symbol explanation.

RACE



Model 4150 HP™

750 CFM Four Barrel

Part # 0-80528-1^(B)



Features

- Designed for use on race engines
- Includes notched float and jet extensions
- Progressive Secondaries
- Dual 30cc accelerator pumps
- Vacuum ports
- Calibrated for gasoline
- Dual fuel inlets
- 4 corner idle
- Screw in air bleeds
- Down leg boosters
- Venturii Size 1.376
- Throttle bore 1.687
- Stainless steel throttle plates
- See pages 40 & 41 for more details & applications

RACE



Model 4150 HP™

750 CFM Four Barrel

Part # 0-80535-1^(B)



Features

- Designed for use on race engines
- Progressive Secondaries
- Dual 30cc accelerator pumps
- Calibrated for methanol
- Dual fuel inlets
- 4 corner idle
- Screw in air bleeds
- Double step, down leg boosters
- Venturii Size 1.376
- Throttle bore 1.688
- Stainless steel throttle plates
- See pages 40 & 41 for more details & applications

RACE



Model 4150 HP™

750 CFM Four Barrel

Part # 0-80675^(B)



Features

- Designed for use on race engines
- Billet Aluminum metering blocks with changeable emulsion bleeds and idle feed restrictors
- Billet Aluminum base plate for strength and durability
- Large glass sight windows for quick fuel level adjustments
- Includes notched float and jet extensions
- Progressive Secondaries
- Dual 30cc accelerator pumps
- Calibrated for gasoline
- Dual fuel inlets
- 4 corner idle
- Screw in air bleeds
- Down leg boosters
- Venturii Size 1.376
- Throttle bore 1.688
- Stainless Steel throttle plates
- See pages 42 & 43 for more details & applications

RACE



Model 4500 HP™

750 CFM Four Barrel

Part # 0-80186-1^(B)



Features

- Designed for use Drag race or Pro Street engines
- Calibrated for a 1x4 setup
- Includes notched float and jet extensions
- Progressive Secondaries
- Dual 50cc accelerator pumps
- 2 Circuit Metering
- Calibrated for Gasoline
- Dual fuel inlets
- 4 corner idle
- Screw in air bleeds
- Annular Boosters
- Venturii Size 1.690
- Throttle bore 2.000
- Aluminum throttle plates
- See pages 44 & 45 for more details & applications

STREET/
RACE



Model 4150™

750 CFM Four Barrel

Part # 0-4779C^(B) 3 - Dichromate finish

Part # 0-4779S^(B) 3 - Shiny finish

Features

- Mechanical secondaries
- Dual accelerator pumps
- Manual choke
- Four corner idle for precise idle control
- Dual feed fuel inlet
- 1 timed (spark) port, 1 full vacuum, and 1 PCV port
- Intended for lightweight vehicles w/ manual trans or automatics with high stall & low gearing
- Installation & Tuning DVD included
- See pages 18 & 19 for more details & applications



OPTIONAL PARTS & KITS

P/N	DESCRIPTION
20-88	GM Throttle cable/return spring bracket kit
36-181	Jet kit
20-12	Pump cam assortment kit
36-184	Accelerator pump tuning kit
20-122	Pro series secondary linkage
36-182	Tuning calibration kit
26-137	Secondary adjusting lever kit
34-39	Billet adjustable fuel log
20-124	Universal install kit

STREET/
RACE



Model 4150 HP™

750 CFM Four Barrel

Part # 0-82750^(B) 3

Features

- Vacuum secondaries allows use on a wide range of vehicles
- Dual accelerator pumps
- Manual choke
- Choke horn removed for increased airflow
- Ford A/T kickdown, does not work with A.O.D. transmissions
- Four corner idle for precise idle control
- Dual feed fuel inlet
- 1 timed (spark) port, 1 full vacuum, and 1 PCV port
- Street/race calibration for outstanding throttle response & drivability
- Installation & Tuning DVD included
- See pages 20 & 21 for more details & applications



OPTIONAL PARTS & KITS

P/N	DESCRIPTION
20-88	GM Throttle cable/return spring bracket kit
34-150	Chrome fuel line
17-6	Spread bore manifold adapter
20-13	Secondary diaphragm spring kit
20-124	Universal installation kit
36-181	Jet kit
36-240	Air bleed kit
20-12	Pump cam assortment kit
36-184	Accelerator pump tuning kit
34-39	Billet adjustable fuel log
20-91	Ford automatic transmission bracket kit

STREET/
RACE



Model 4150 HP™

750 CFM Four Barrel

Part # 0-82751^(B) 3

Features

- Mechanical secondaries
- Dual accelerator pumps
- Manual choke
- Choke horn removed for increased airflow
- Ford A/T kickdown, does not work with A.O.D. transmissions
- Four corner idle for precise idle control
- Dual feed fuel inlet
- 1 timed (spark) port, 1 full vacuum, and 1 PCV port
- Intended for lightweight vehicles w/ manual trans or automatics with high stall & low gearing. Street/race calibration for outstanding throttle response & drivability
- Installation & Tuning DVD included
- See pages 20 & 21 for more details & applications



OPTIONAL PARTS & KITS

P/N	DESCRIPTION
20-88	GM Throttle cable/return spring bracket kit
34-150	Chrome fuel line
17-6	Spread bore manifold adapter
20-124	Universal installation kit
36-181	Jet kit
36-240	Air bleed kit
20-122	Pro series secondary linkage
20-12	Pump cam assortment kit
36-184	Accelerator pump tuning kit
34-39	Billet adjustable fuel log
26-137	Secondary adjusting lever kit
20-91	Ford automatic transmission bracket kit

STREET/
RACE



Model 4150™

800 CFM Four Barrel

Part # 0-4780C^(B) 3 - Dichromate finish

Part # 0-4780S^(B) 3 - Shiny finish

Features

- Mechanical secondaries
- Dual accelerator pumps
- Manual choke
- Two corner idle
- Dual feed fuel inlet
- 1 timed (spark) port, 1 full vacuum, and 1 PCV port
- Intended for lightweight vehicles w/ manual trans or automatics with high stall & low gearing
- Installation & Tuning DVD included
- See pages 18 & 19 for more details & applications



OPTIONAL PARTS & KITS

P/N	DESCRIPTION
20-88	GM Throttle cable/return spring bracket kit
36-181	Jet kit
34-150	Chrome fuel line
20-12	Pump cam assortment kit
36-184	Accelerator pump tuning kit
20-122	Pro series secondary linkage
36-182	Tuning calibration kit
26-137	Secondary adjusting lever kit
34-39	Billet adjustable fuel log
20-124	Universal install kit

RACE



Model 4150™

830 CFM Four Barrel

Part # 0-9381^(B) 3



Features

- No choke hardware
- Center hung float bowls
- Dual 30cc accelerator pumps
- Annular style boosters
- Mechanical secondaries
- Four-corner idle system
- See pages 38 & 39 for more details & applications

OPTIONAL PARTS & KITS

P/N	DESCRIPTION
36-181	Jet kit
20-12	Pump cam assortment kit
36-184	Accelerator pump tuning kit
20-122	Pro series secondary linkage
36-182	Tuning calibration kit
26-137	Secondary adjusting lever kit
34-39	Billet adjustable fuel log
20-124	Universal install kit

RACE



Model 4150 HP™

830 CFM Four Barrel

Part # 0-80509-1^(B) 3



Features

- NASCAR Approved
- Designed for use on circle track engines
- Progressive Secondaries
- Dual 30cc accelerator pumps
- Calibrated for gasoline
- Dual fuel inlets
- 4 corner idle
- Screw in air bleeds
- Down leg Boosters
- Venturii Size 1.561
- Throttle bore 1.687
- Stainless Steel throttle plates
- See pages 40 & 41 for more details & applications

RACE



Model 4150 HP™

830 CFM Four Barrel

Part # 0-80511-1^(B) 3



Features

- NASCAR Approved
- Designed for use on circle track engines
- Progressive Secondaries
- Dual 30cc accelerator pumps
- Calibrated for gasoline
- Dual fuel inlets
- 4 corner idle
- Includes notched floats and jet extensions
- Screw in air bleeds
- Annular Boosters
- Venturii Size 1.561
- Throttle bore 1.687
- Stainless Steel throttle plates
- See pages 40 & 41 for more details & applications

RACE



Model 4150™

850 CFM Four Barrel

Part # 0-9380^(B) 3



Features

- No choke
- Center hung float bowls
- 30cc Primary accelerator pump
- 50cc Secondary accelerator pump
- Annular-style boosters
- Mechanical secondaries
- Four corner idle system
- See pages 38 & 39 for more details & applications

OPTIONAL PARTS & KITS

P/N	DESCRIPTION
36-181	Jet kit
20-12	Pump cam assortment kit
36-184	Accelerator pump tuning kit
20-122	Pro series secondary linkage
36-182	Tuning calibration kit
26-137	Secondary adjusting lever kit
34-39	Billet adjustable fuel log
20-124	Universal install kit

**STREET/
RACE**



Model 4150™

850 CFM Four Barrel

Part # 0-4781C^(B) - Dichromate finish

Part # 0-4781S^(B) - Shiny finish



Features

- Mechanical secondaries
- Dual accelerator pumps (Double Pumper®)
- Manual choke
- Four corner idle for precise idle control
- Dual feed fuel inlet
- 1 timed (spark) port, 1 full vacuum, and 1 PCV port
- Intended for lightweight vehicles w/ manual trans or automatics with high stall & low gearing
- Installation & Tuning DVD included
- See pages 18 & 19 for more details & applications

OPTIONAL PARTS & KITS

P/N	DESCRIPTION
20-88	Throttle cable/return spring bracket kit
36-181	Jet kit
20-12	Pump cam assortment kit
36-184	Accelerator pump tuning kit
20-122	Pro series secondary linkage
36-182	Tuning calibration kit
26-137	Secondary adjusting lever kit
34-39	Billet adjustable fuel log
20-124	Universal install kit

RACE



Model 4150 HP™

950 CFM Four Barrel

Part # 0-80496-1^(B)



Features

- Designed for use on race engines
- Progressive Secondaries
- Dual 30cc accelerator pumps
- Calibrated for gasoline
- Dual fuel inlets
- 4 corner idle
- Screw in air bleeds
- Double Step, Down leg Boosters
- Venturii Size 1.376
- Throttle bore 1.750
- Stainless steel throttle plates
- See pages 40 & 41 for more details & applications



RACE



METHANOL
Model 4150 HP™

950 CFM Four Barrel

Part # 0-80498-1^(B)



Features

- Designed for use on race engines
- Progressive Secondaries
- Dual 50cc accelerator pumps
- Calibrated for methanol
- Dual fuel inlets
- 4 corner idle
- Screw in air bleeds
- Double Step, Down leg Boosters
- Venturii Size 1.376
- Throttle bore 1.750
- Stainless steel throttle plates
- See pages 40 & 41 for more details & applications



RACE



Model 4150 HP™

950 CFM Four Barrel

Part # 0-80676^(B)



Features

- Designed for use on race engines
- Billet Aluminum metering blocks with changeable emulsion bleeds and idle feed restrictors
- Billet Aluminum base plate for strength and durability
- Large glass sight windows for quick fuel level adjustments
- Includes notched float and jet extensions
- Progressive Secondaries
- Dual 30cc accelerator pumps
- Calibrated for gasoline
- Dual fuel inlets
- 4 corner idle
- Screw in air bleeds
- Down leg boosters
- Venturii Size 1.376
- Throttle bore 1.750
- Stainless Steel throttle plates
- See pages 42 & 43 for more details & applications



RACE



Model 4150 HP™

1000 CFM Four Barrel

Part # 0-80513-1^(B) 3

Features

- Designed for use on race engines
- Includes notched float and jet extensions
- Progressive Secondaries
- 30cc primary and 50cc secondary accelerator pumps
- Calibrated for gasoline
- Dual fuel inlets
- 4 corner idle
- Screw in air bleeds
- Down leg boosters
- Venturii size 1.561
- Throttle bore 1.750
- Stainless steel throttle plates
- See pages 40 & 41 for more details & applications



RACE



Model 4150 HP™

1000 CFM Four Barrel

Part # 0-80514-1^(B) 3

Features

- Designed for use on race engines
- Includes notched float and jet extensions
- Progressive Secondaries
- 30cc primary and 50cc secondary accelerator pumps
- Calibrated for gasoline
- Dual fuel inlets
- 4 corner idle
- Screw in air bleeds
- Annular Boosters
- Venturii Size 1.561
- Throttle bore 1.750
- Stainless steel throttle plates
- See pages 40 & 41 for more details & applications



RACE



Model 4500 HP™

1050 CFM Four Barrel

Part # 0-8082-1^(B) 3

Features

- Designed for use on Drag race engines
- Calibrated for a 1x4 setup
- Includes notched float and jet extensions
- Progressive Secondaries
- Dual 50cc accelerator pumps
- 2 Circuit Metering
- Calibrated for Gasoline
- Dual fuel inlets
- 4 corner idle
- Screw in air bleeds
- Annular Boosters
- Venturii Size 1.690
- Throttle bore 2.000
- Aluminum throttle plates
- See pages 44 & 45 for more details & applications



RACE



Model 4500 HP™

1050 CFM Four Barrel

Part # 0-8896-1^(B) 3

Features

- Designed for use on Drag race engines
- Calibrated for a 1x4 setup
- Includes notched float and jet extensions
- Soft Progressive Secondaries
- Dual 50cc accelerator pumps
- 3 Circuit Metering for enhanced tunability
- Calibrated for Gasoline
- Dual fuel inlets
- 4 corner idle
- Screw in air bleeds
- Annular Boosters
- Venturii Size 1.690
- Throttle bore 2.000
- Aluminum throttle plates
- See pages 44 & 45 for more details & applications



RACE



METHANOL
Model 4500 HP™

1050 CFM Four Barrel

Part # 0-80586^(B) 

Features

- Designed for use on Drag race engines
- Calibrated for a 1x4 setup
- Progressive Secondaries
- Dual 50cc accelerator pumps
- 3 Circuit Metering for enhanced tunability
- Calibrated for methanol
- Dual fuel inlets
- 4 corner idle
- Screw in air bleeds
- Annular Boosters
- Venturii Size 1.690
- Throttle bore 2.000
- Aluminum throttle plates
- See pages 44 & 45 for more details & applications



RACE



Model 4500 HP™

1050 CFM Four Barrel

Part # 0-9375-1^(B) 

Features

- Designed for use on Drag race engines
- Calibrated for a 2x4 setup
- Soft Progressive Secondaries
- Dual 50cc accelerator pumps
- 3 Circuit Metering for enhanced tunability
- Calibrated for Gasoline
- Dual fuel inlets
- 4 corner idle
- Screw in air bleeds
- Annular Boosters
- Venturii Size 1.690
- Throttle bore 2.000
- Aluminum throttle plates
- See pages 44 & 45 for more details & applications



RACE



Model 4500 HP™

1050 CFM Four Barrel

Part # 0-80672^(B) 

Features

- Designed for use on Drag race engines
- Billet Aluminum metering blocks with changeable emulsion bleeds and idle feed restrictors
- Large glass sight windows for quick fuel level adjustments
- Includes notched float and jet extensions
- Calibrated for a 1x4 setup
- Progressive Secondaries
- Dual 50cc accelerator pumps
- 3 Circuit Metering for enhanced tunability
- Calibrated for Gasoline
- Dual fuel inlets
- 4 corner idle
- Screw in air bleeds
- Annular Boosters
- Venturii Size 1.690
- throttle bore 2.000
- Aluminum throttle plates
- See pages 46 & 47 for more details & applications



RACE



Model 4500 HP™

1150 CFM Four Barrel

Part # 0-7320-1^(B) 

Features

- Designed for use on Drag race engines
- Calibrated for a 1x4 setup
- Includes notched float and jet extensions
- Progressive Secondaries
- Dual 50cc accelerator pumps
- 2 Circuit Metering
- Calibrated for Gasoline
- Dual fuel inlets
- 4 corner idle
- Screw in air bleeds
- Annular Boosters
- Venturii Size 1.830
- Throttle bore 2.000
- Aluminum throttle plates
- See pages 44 & 45 for more details & applications



RACE



Model 4500 HP™

1150 CFM Four Barrel

Part # 0-80556-1^(B) 3

Features

- Designed for use on Drag race engines
- Calibrated for a 1x4 setup
- Includes notched float and jet extensions
- Soft Progressive Secondaries
- Dual 50cc accelerator pumps
- 3 Circuit Metering for enhanced tunability
- Calibrated for Gasoline
- Dual fuel inlets
- 4 corner idle
- Screw in air bleeds
- Annular Boosters
- Venturii Size 1.830
- Throttle bore 2.000
- Aluminum throttle plates
- See pages 44 & 45 for more details & applications



RACE



Model 4500 HP™

1150 CFM Four Barrel

Part # 0-9377-1^(B) 3

Features

- Designed for use on Drag race engines
- Calibrated for a 2x4 setup
- Soft Progressive Secondaries
- Dual 50cc accelerator pumps
- 3 Circuit Metering for enhanced tunability
- Calibrated for Gasoline
- Dual fuel inlets
- 4 corner idle
- Screw in air bleeds
- Annular Boosters
- Venturii Size 1.830
- Throttle bore 2.000
- Aluminum throttle plates
- See pages 44 & 45 for more details & applications



RACE



Model 4500 HP™

1150 CFM Four Barrel

Part # 0-80673^(B) 3

Features

- Designed for use on Drag race engines
- Billet Aluminum metering blocks with changeable emulsion bleeds and idle feed restrictors
- Large glass sight windows for quick fuel level adjustments
- Includes notched float and jet extensions
- Calibrated for a 1x4 setup
- Progressive Secondaries
- Dual 50cc accelerator pumps
- 3 Circuit Metering for enhanced tunability
- Calibrated for Gasoline
- Dual fuel inlets
- 4 corner idle
- Screw in air bleeds
- Annular Boosters
- Venturii Size 1.830
- Throttle bore 2.000
- Aluminum throttle plates
- See pages 46 & 47 for more details & applications



RACE

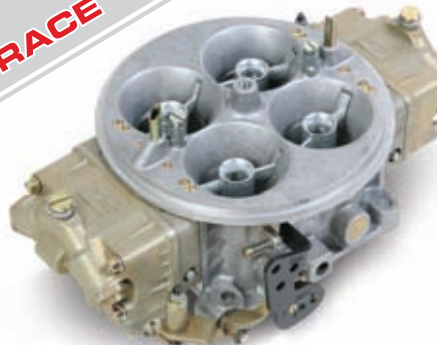

Model 4500 HP™

1250 CFM Four Barrel

Part # 0-80532-1^(B) 3

Features

- Designed for use on Drag race engines
- Calibrated for a 1x4 setup
- Includes notched float and jet extensions
- Progressive Secondaries
- Dual 50cc accelerator pumps
- 3 Circuit Metering for enhanced tunability
- Calibrated for Gasoline
- Dual fuel inlets
- 4 corner idle
- Screw in air bleeds
- Annular Boosters
- Venturii Size 1.880"
- Throttle bore 2.125"
- Aluminum throttle plates
- See pages 44 & 45 for more details & applications



Marine Carburetors

Designed and built specially for marine conditions and usage.



Marine "J-style" vent tubes: direct fuel/fumes back into carburetor for safe operation

Marine calibrations: Compensate for unique engine loads found on boats

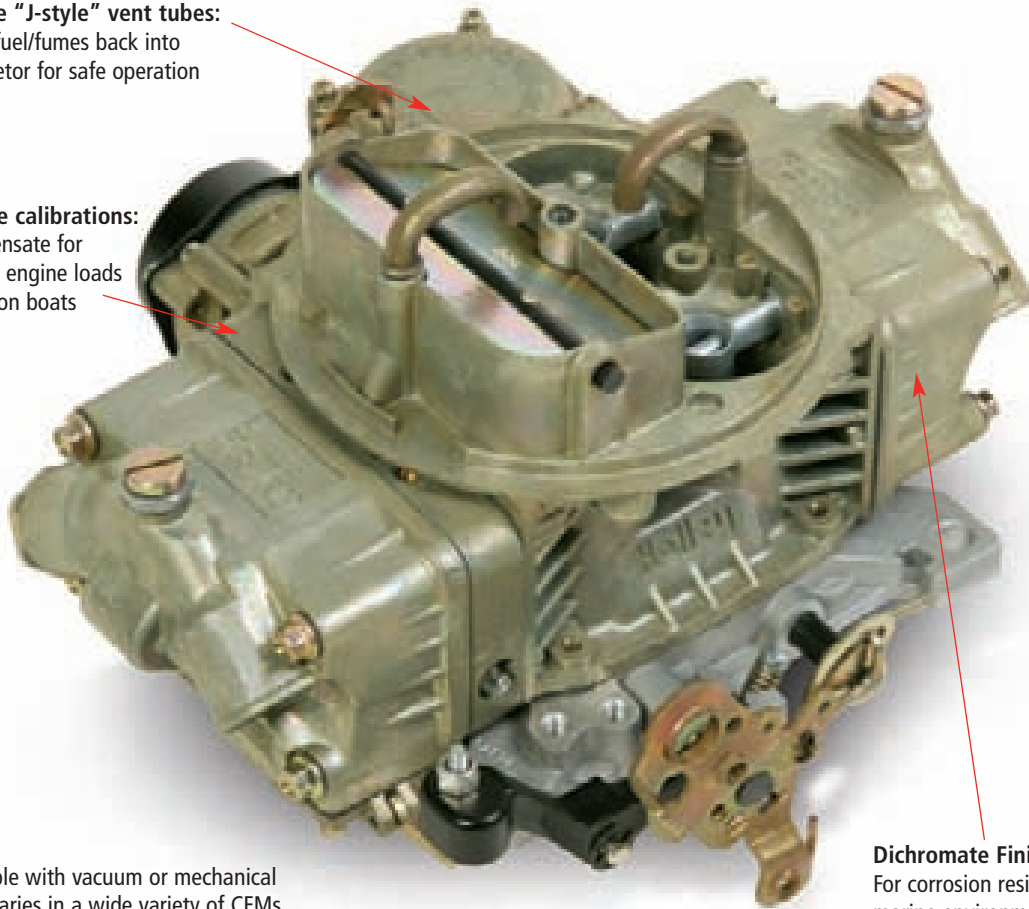

Power Valve Blow-out Protection

Dichromate Finish: For corrosion resistance in harsh marine environments

Available with vacuum or mechanical secondaries in a wide variety of CFMs

100% wet-flow tested & calibrated to ensure out-of-the-box performance

MEET COAST GUARD SPECIFICATIONS

Description	Dichromate Zinc
300 CFM Two Barrel	Part # 0-80320-1
450 CFM Four Barrel	Part # 0-80364
500 CFM Two Barrel	Part # 0-80402-1
600 CFM Four Barrel	Part # 0-80319-1
600 CFM Four Barrel	Part # 0-80318-1
600 CFM Four Barrel	Part # 0-80492
600 CFM Four Barrel	Part # 0-80551
600 CFM Four Barrel	Part # 0-80559
650 CFM Four Barrel	Part # 0-80552
750 CFM Four Barrel	Part # 0-80537
750 CFM Four Barrel	Part # 0-9015-1
800 CFM Four Barrel	Part # 0-9022
850 CFM Four Barrel	Part # 0-80443
MARINE 4-BBL DOMINATOR® 4500 CARBURETORS	
1050 CFM Four Barrel	Part # 0-80340-1

NOTE: See following pages for detailed descriptions

MARINE



Model 2300™

300 CFM Two Barrel

Part # 0-80320-1



Application

- Ford Marine 302 CID (5.0 Liter) V-8

Features

- Model 2300
- Electric choke
- 30cc accelerator pump
- Single fuel inlet
- 5" airhorn

OPTIONAL PARTS & KITS

P/N	DESCRIPTION
703-30	Renew Kit

MARINE



Model 4160™

450 CFM Four Barrel

Part # 0-80364



Application

- Ford Marine 302 CID (5.0 Liter) V-8

Features

- Model 4160
- Vacuum Secondaries
- Electric choke
- 30cc accelerator pump
- Single fuel inlet
- 5" airhorn

OPTIONAL PARTS & KITS

P/N	DESCRIPTION
703-28	Renew Kit
20-13	Secondary diaphragm spring kit
20-59	Quick change secondary spring kit

MARINE



Model 2300™

500 CFM Two Barrel

Part # 0-80402-1



Features

- Model 2300
- Universal marine calibration
- Electric choke
- 30cc accelerator pump
- Single fuel inlet
- 5" airhorn

OPTIONAL PARTS & KITS

P/N	DESCRIPTION
703-30	Renew Kit

MARINE



Model 4160™

600 CFM Four Barrel

Part # 0-80319-1



Application

- Ford Marine 351 CID (5.8 Liter) V-8

Features

- Model 4160
- Vacuum Secondaries
- Electric choke
- 30cc accelerator pump
- Single fuel inlet
- 5" airhorn

OPTIONAL PARTS & KITS

P/N	DESCRIPTION
703-47	Renew Kit
20-13	Secondary diaphragm spring kit
20-59	Quick change secondary spring kit

MARINE



Model 4160™

600 CFM Four Barrel

Part # 0-80318-1



Application

- Ford Marine 460 CID (7.5 Liter) V-8

Features

- Model 4160
- Vacuum Secondaries
- Electric choke
- 30cc accelerator pump
- Single fuel inlet
- 5" airhorn

OPTIONAL PARTS & KITS

P/N	DESCRIPTION
703-33	Renew Kit
20-13	Secondary diaphragm spring kit
20-59	Quick change secondary spring kit

MARINE



Model 4160™

600 CFM Four Barrel

Part # 0-80492



Application

- OMC & Volvo Marine 4.3 Liter V-6

Features

- Model 4160
- Vacuum Secondaries
- Automatic electric choke
- 30cc accelerator pump
- Single fuel inlet
- 5" airhorn

OPTIONAL PARTS & KITS

P/N	DESCRIPTION
703-29	Renew Kit

MARINE



Model 4160™

600 CFM Four Barrel

Part # 0-80551



Features

- Model 4160
- Universal marine calibration
- Vacuum Secondaries
- Electric choke
- 30cc accelerator pump
- Single fuel inlet
- 5" airhorn

OPTIONAL PARTS & KITS

P/N	DESCRIPTION
703-1	Renew Kit
20-13	Secondary diaphragm spring kit
20-59	Quick change secondary spring kit

MARINE



Model 4150™

600 CFM Four Barrel

Part # 0-80559



Features

- Model 4150
- Performance calibration
- Mechanical secondaries
- Electric choke
- 30cc accelerator pumps (Double Pumper™)
- Dual fuel inlets

OPTIONAL PARTS & KITS

P/N	DESCRIPTION
734-4	Chrome fuel line



Model 4175™

650 CFM Four Barrel

Part # 0-80552



Features

- Model 4175
- Quadra-Jet replacement
- Vacuum secondaries
- Electric choke
- 30cc accelerator pump
- 5" airhorn

NOTE: May require spacer to clear water outlet

OPTIONAL PARTS & KITS

P/N	DESCRIPTION
703-34	Renew Kit
20-13	Secondary spring assortment



Model 4150™

750 CFM Four Barrel

Part # 0-80537



Features

- Model 4150
- Performance calibration
- Mechanical secondaries
- Four corner idle system
- Manual choke
- Dual fuel inlets
- 30cc accelerator pump
- 5" airhorn

OPTIONAL PARTS & KITS

P/N	DESCRIPTION
3-485	Renew Kit
734-4	Chrome fuel line
745-224	Electric choke conversion kit



Model 4160™

750 CFM Four Barrel

Part # 0-9015-1



Features

- Model 4160
- Universal marine calibration
- Vacuum secondaries
- Electric choke
- Dual fuel inlets
- 30cc accelerator pump
- 5" airhorn

OPTIONAL PARTS & KITS

P/N	DESCRIPTION
3-720	Renew Kit
20-13	Secondary spring assortment
20-59	Secondary quick change spring kit

MARINE



Model 4150™

800 CFM Four Barrel

Part # 0-9022



Features

- Model 4150
- Universal Marine calibration
- Mechanical secondaries
- Manual choke
- Dual fuel inlets
- 30cc primary pump
- 50cc secondary pump
- 5" airhorn

OPTIONAL PARTS & KITS

P/N	DESCRIPTION
3-485	Renew Kit
734-4	Chrome fuel line
7 45-224	Electric choke conversion kit

MARINE



Model 4150™

850 CFM Four Barrel

Part # 0-80443



Features

- Model 4150
- Universal Marine calibration
- Mechanical secondaries
- Automatic electric choke
- Dual fuel inlets
- 30cc primary pump
- 50cc secondary pump
- 5" airhorn

OPTIONAL PARTS & KITS

P/N	DESCRIPTION
703-58	Renew Kit
734-4	Chrome fuel line

MARINE



Model 4500™

1050 CFM Four Barrel

Part # 0-80340-1



Features

- Model 4500 DOMINATOR HP
- Dual feed float bowls
- Progressive linkage
- Dual 50cc accelerator pumps
- Four corner idle system
- 2-circuit metering
- Replaceable air bleeds
- NitroPhyl™ floats

OPTIONAL PARTS & KITS

P/N	DESCRIPTION
37-1539	Renew Kit
717-8	Throttle bracket

HOW TO CHOOSE A CARB CARBURETORS SUPERCHARGER CARBURETORS RACE CARBURETORS MARINE CARBURETORS CARB SERVICE PARTS & ACCESSORIES FUEL INJECTION THROTTLE BODIES FUEL PUMPS INTAKE MANIFOLDS CYLINDER HEADS SYSTEMAX ENGINE DRESS-UP MERCHANDISING TECHNICAL INFORMATION INDEX

Exploded view and description of Model 4160 Carburetor

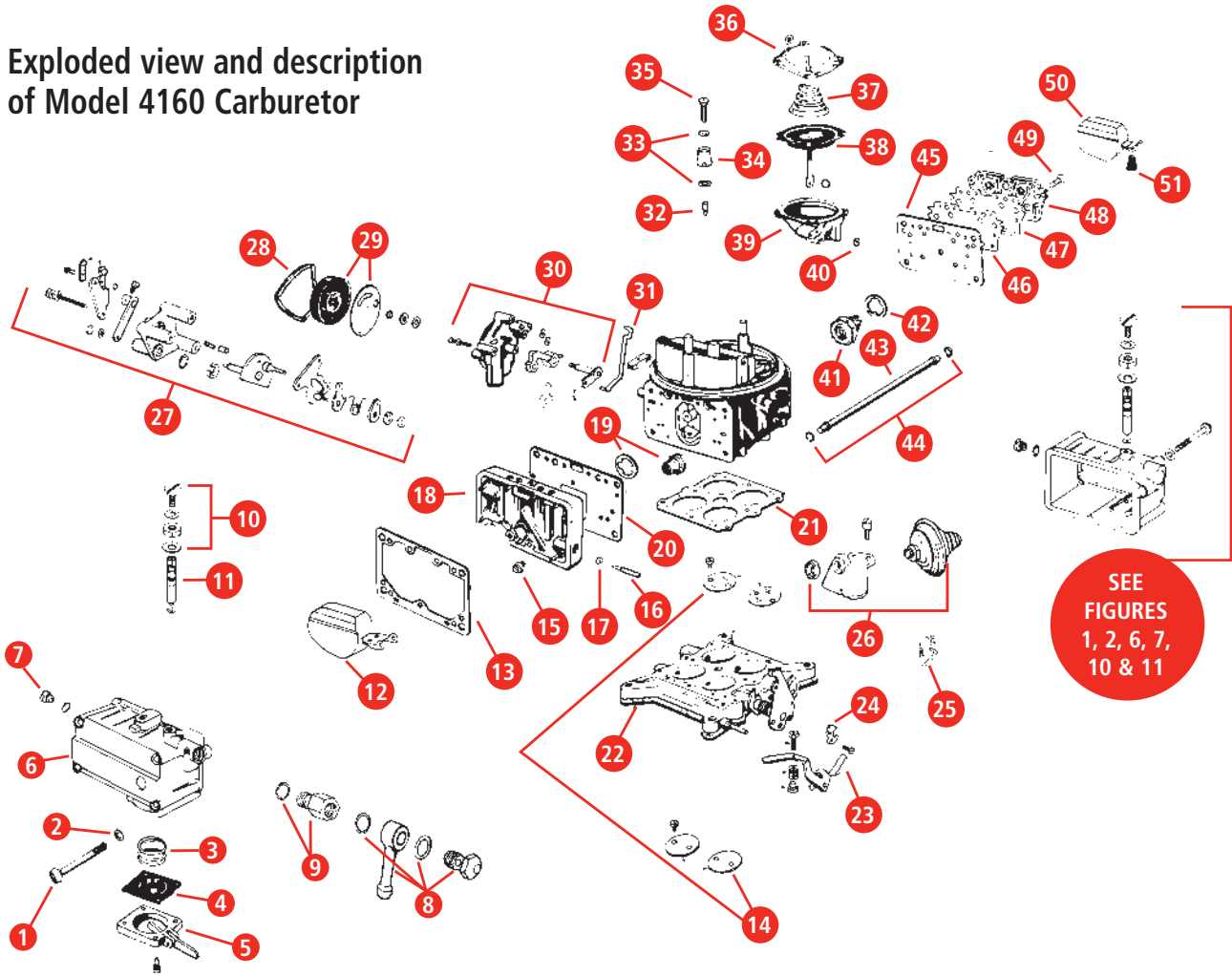

NO.	DESCRIPTION
1	Fuel Bowl Screw - see fuel bowl section; pg. 74
2	Fuel Bowl Screw Gasket - 108-2-20; pg. 75
3	Accelerator Pump Spring - (30cc) 20-108-10; pg. 65 (50cc) 20-109-10; pg. 65
4	Accelerator Pump Diaphragm - (30cc) 135-5; pg. 66 (50cc) 135-7; pg. 66
5	Accelerator Pump cover w/screws - CHROME (30cc) 34-504, (50cc) 34-505; pg. 65 - STANDARD (30cc) 26-139, (50cc) 26-140 - POLISHED (30cc) 26-139P, (50cc) 26-140P
6	fuel bowl - see numerical listing; pgs.172-191
7	Sight Plug & Gasket - 26-13 (brass) pg. 75, 26-113 (clear); pg. 75
8	Fuel Inlet Banjo Fitting - 26-25; pg. 75
9	Universal Fuel Inlet - see fitting section; pg. 72
10	Needle & Seat Hardware - 34-7; pg. 91
11	Needle & Seats (adjustable & non-adjustable) - see needle & seat section; pg. 91
12	Float - see float section; pg. 73
13	Primary Bowl Gasket - see gasket section; pg. 78-84
14	Throttle Plate kit w/ screws - see throttle plate section; pg. 68
15	Main Jet - see jet section; pg. 87-89
16	Idle Adjusting Needle - 26-101 pg. 90
17	Needle Seal - 26-110-10; pg. 90
18	Primary Metering Block - See numerical listing; pgs. 172-191
19	Power Valve - see power valve section; pg. 92-93
20	Metering Block Gasket - see gasket section; pg. 78-84

NO.	DESCRIPTION
21	Throttle Body Gasket - see gasket section; pg. 78-84
22	Base Plate - see numerical listing; pgs. 172-191
23	30cc Accelerator Pump Arm - 20-78 (plastic), 20-114 (metal); pg. 65
24	Pump Cam Assortment - 20-11; pg. 65
25	Secondary Connecting Link - see linkage section; pg. 68-70
26	Dashpot/bracket/solenoid - see bracket section; pg. 68-70
27	Manual Choke Kit - 45-225; pg. 70
28	Choke Cap Retainer - 45-377; pg. 70
29	Electric Choke Cap - 45-258; pg. 71
30	Electric Choke Kit - 45-223 (internal vacuum source); pg. 70 - 45-224 (external vacuum source); pg. 70
31	Choke Rod Assortment - 45-520; pg. 71
32	Accelerator Discharge Check Needle
33	Accelerator Discharge Nozzle Gasket - 1008-884; pg. 66
34	Accelerator Discharge Nozzle - see nozzle section; pg. 66
35	Accelerator Discharge Nozzle Screw - (SOLID) 121-6, (HOLLOW) 121-7 pg. 66
36	Secondary Diaphragm Cover - (standard) 20-85; pg. 89, - (quick change) 20-95; pg. 94
37	Vacuum Secondary Spring - 20-13 (assortment kit); pg. 75

NO.	DESCRIPTION
38	Vacuum Secondary Diaphragm - see secondary diaphragm section; pg. 94
39	Vacuum Secondary Lower Housing - 34-503 (includes chrome standard top); pg. 95
40	Vacuum Secondary Housing to Main Body Gasket - 108-67-20 (20 pkg.); pg. 79
41	Power Valve - see power valve section; pg. 92-93
42	Power Valve Gasket - (full round style) 1008-1597 (10 pkg.), (round w/ protrusions on I.D.) 1008-669 (10 pkg.)
43	Fuel Transfer Tube - 26-115 (model 4160), 26-114 (model 4150 & 4175), 26-116 (model 4165); pg. 75
44	Fuel Transfer Tube Seals - 108-97 (replacement viton seal for new style transfer tube), 26-37 (replacement o-rings for old-style transfer tube); pg. 79
45	Secondary Fuel Bowl Gasket - see gasket section; pgs. 78-84
46	Secondary Sealing Plate - 108-122 (only required when main body has secondary power valve cavity)
47	Secondary Metering Plate Gasket - see gasket section; pg. 78-84
48	Secondary Metering Plate - see metering plate section; pg. 90
49	Secondary Plate Screws - 26-123 (clutch head screw) pg. 80
50	Secondary Float - see float section; pg. 73
51	Side Hung Float Spring - 20-123

Accelerator Pump Cam



"White" pump cam for model 4500 DOMINATOR carburetors. Profile design gives a quick, early shot of fuel but it does not empty the pump. **Part # 20-80**

"Yellow" pump cam for model 4500 DOMINATOR carburetors. Profile design delivers an early fuel shot and continues until the pump empties. **Part # 20-81**

Accelerator Pump Cam Assortment Kit **Part # 20-12**

Another great tuning kit from Holley. This one will allow you to "tailor" accelerator pump performance to the engine's actual requirements. Each cam has a different shape or profile to give different results. Cam "lift" directly affects the accelerator pump stroke and, therefore, pump capacity. Ramp profile or shape controls the "timing" of the shot. A steeply-rising ramp shape will give a fast, heavy fuel shot right off idle. Conversely, a gently sloping ramp will spread the pump action over a longer period of time.



Pump Cam Lift vs. Throttle Position

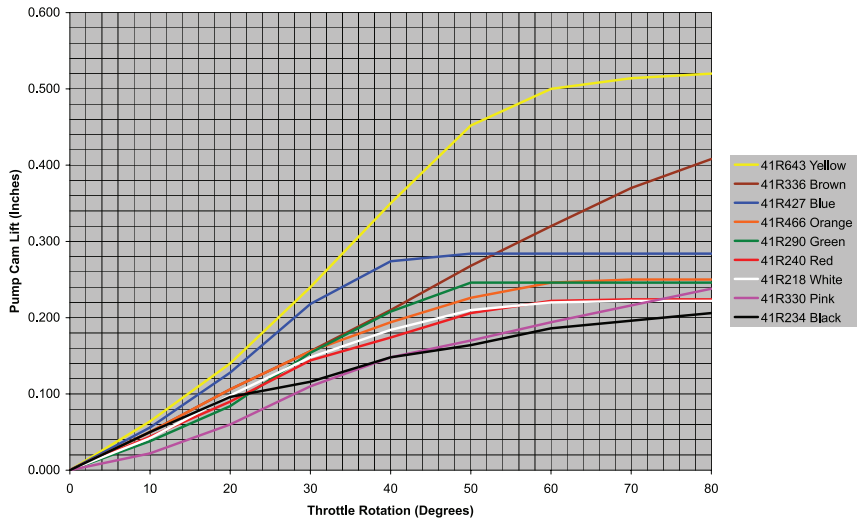

Accelerator Pump Conversion Kit - 50cc **Part # 20-11**



Models 2300, 4150 and 4160

Instantaneous response! Pull strongly throughout the RPM band! A "must" for tunnel ram setups! This kit is for those who demand ultimate performance from their Holley carburetor(s). The Holley 50cc accelerator pump will substantially increase fuel capacity over the standard 30cc pump system. Eliminates flat spots off idle or at any other RPM range. This kit includes everything required for easy installation including new pump housing, stud, arm, diaphragm, spring and longer pump housing screws.

Accelerator Pump

- Transfer Tube **Part # 26-23**
- Transfer Tube O-Ring **Part # 26-38**



Pump cup/stem

- Model 4360 **Part # 135-1**



Accelerator Pump Spring (10 pack)

- 30cc **Part # 20-108-10**
- 50cc **Part # 20-109-10**



Pump cover - chrome

- 30cc pump. **Part # 34-504**
- 50cc pump. **Part # 34-505**



Pump covers (including lever & screws)

- 30cc pump standard **Part # 26-139**
- 30cc pump polished **Part # 26-139P**
- 50cc pump standard **Part # 26-140**
- 50cc pump polished **Part # 26-140P**



Pump arm

- Models 2300, 4150, 4160 (plastic) **Part # 20-78**
- 30cc pump arm (metal) **Part # 20-114**



HOW TO CHOOSE A CARB
STREET CARBURETORS
SUPERCHARGER CARBURETORS
RACE CARBURETORS
MARINE CARBURETORS
CARB SERVICE PARTS & ACCESSORIES
FUEL INJECTION
THROTTLE BODIES
FUEL PUMPS
INTAKE MANIFOLDS
CYLINDER HEADS
SYSTEMAX
ENGINE DRESS-UP
MERCHANDISING
TECHNICAL INFORMATION
INDEX

HOW TO CHOOSE A CARB
STREET CARBURETORS
SUPERCHARGER CARBURETORS
RACE CARBURETORS
MARINE CARBURETORS
CARB SERVICE PARTS & ACCESSORIES
FUEL INJECTION
THROTTLE BODIES
FUEL PUMPS
INTAKE MANIFOLDS
CYLINDER HEADS
SYSTEMAX
ENGINE DRESS-UP
MERCHANDISING
TECHNICAL INFORMATION
INDEX

“Umbrella” Check Valve..... Part # 26-41

Diaphragms

- 30cc (rubber) w/o screws..... Part # 135-5
- 30cc (rubber) w/ screws..... Part # 135-12
- 30cc (GFLT)* w/o screws..... Part # 135-10
- 50cc (rubber) w/o screws..... Part # 135-7
- 50cc (rubber) w/ screws..... Part # 135-14
- 50cc (GFLT)* w/o screws..... Part # 135-9
- 50cc (GFLT)* w/ screws..... Part # 135-15

*GFLT Diaphragms are compatible for use with all alcohol base fuels.



ACCELERATOR PUMP DISCHARGE NOZZLES

A good selection of accelerator pump discharge nozzle sizes is indispensable to the proper tuning of the accelerator pump system. The nozzle hole size determines the rate of fuel discharge. A larger hole will “shoot” the fuel at a faster rate, and with less pressure, than a smaller hole. Sizes are stamped on each nozzle. For example, the number “31” indicates that the nozzle hole size is .031”. Various styles of nozzles are offered by Holley, including the following:

NOTE: Nozzle sizes .040” and larger include a hollow nozzle screw.

Straight Type

(includes 2 nozzles & 4 gaskets)
Used on Models 4150, 4160 and 4500

PART #	HOLE
121-118	.018
121-121	.021
121-125	.025
121-128	.028
121-131	.031
121-132	.032
121-135	.035
121-137	.037
121-140 includes hollow pump screw	.040
121-142 includes hollow pump screw	.042
121-145 includes hollow pump screw	.045
121-147 includes hollow pump screw	.047
121-150 includes hollow pump screw	.050

screw hole thread size 12-28



121-131

Anti-Pullover Style

(includes 1 nozzle & 2 gaskets)
Originally used on Models 4165 and 4175

The anti-pullover nozzle can be used on other models as well. This style was designed to combat the condition that’s sometimes called “pump pull-over”. That is, as the stream of air rushes past the pump discharge nozzle it has the tendency to “pull” the fuel from the nozzle. The following anti-pullover styles are available:

PART #	HOLE SIZE
121-225	.025
121-228	.028
121-231	.031
121-237	.037
121-240	.040

screw hole thread size 12-28



121-231

Tube Type

(includes 2 nozzles & 4 gaskets)
Used on Models 4150, 4160 and 4500

PART #	HOLE SIZE
121-25	.025
121-28	.028
121-31	.031
121-35	.035
121-37	.037
121-40 includes hollow pump screw	.040
121-42 includes hollow pump screw	.042
121-45 includes hollow pump screw	.045

screw hole thread size 12-28



121-40

Discharge Nozzle Screws

PART #	DESCRIPTION
121-6	Solid
121-7	Hollow



Thread 12-28

Designed for nozzle size .040 & up

Accelerator Pump Tuning Kit

Part # 36-184^(B)

Contains a selection of accelerator pump hardware components including pump diaphragms, pump nozzles, pump cams and related parts. For Holley 2-bbl and 4-bbl performance carburetors. See “Kits and Assortments” page in this section for details.



36-184

Center Squirter Nozzle

(Used on 0-4224)

PART #	Hole Size
121-325	.025

(includes 2 gaskets)

Squirter Nozzle Gaskets

PART #	Quantity
1008-844	10/Pkg.

ADAPTERS

2300 Flange to Large Rochester 2GC . . . Part # 17-43

Cast aluminum, open (large Rochester pattern 3-3/4" x 2")



17-43

Square Flange to Spread Bore Part # 17-6

Cast aluminum, 5/8" thick (see picture on page 91), This adapter will allow any spread bore carburetor to be mounted on manifolds designed originally for 4150 or 4160 carburetors. **WARNING:** Do not use on manifold with "angle-mounted" carburetor



17-6

Square Flange to DOMINATOR Part # 7539

Cast aluminum, 2" height, This adapter will allow any 4150 or 4160 carburetor to be mounted on a manifold designed originally for a DOMINATOR carburetor



7539

DOMINATOR to Square Bore

Cast aluminum, These adapters allow a DOMINATOR carburetor to be mounted on a manifold designed originally for a 4150 or 4160 carburetor

- 2-1/4" height Part # 17-9
- 2" height Part # 7466



17-9



108-37

SPACERS

Spread Bore Part # 108-37

Phenolic, 5/8" height, will not fit Q-Jet



17-72

2300 Flange Part # 17-72

Phenolic, 1-11/16" bores 1" height

4150 Flange

Phenolic, 1-9/16" bores

- 1/2" height Part # 17-59



17-59

Phenolic, open

- 1/2" height Part # 17-62



17-62

SPACERS (Cont'd)

4150/AFB Flange

Cast aluminum, open

- 1" height Part # 17-27



17-27

- 4-hole, 1" height Part # 17-34



17-34

- 1" height Part # 7465

Dominator Flange

Cast aluminum, shear plate

- with 7° tapered bore. Part # 17-57

Phenolic, open,

- 1" height Part # 17-70

WEDGE PLATES

Spacer, Wedge Plate (aluminum) Part # 717-1

7° wedge with square bore flange allows carburetor to sit level on tilted engine installations. Includes gaskets, studs & nuts.



17-57

Spacer, Wedge Plate (aluminum) Part # 717-2

12° wedge with square bore flange allows carburetor to sit level on tilted engine installations. Includes gaskets, studs & nuts.



717-1

PLENUM DIVIDER KITS

Square Bore Flange Part # 7460

Cast aluminum, 5/8" height Allows the use of a plenum divider on an open plenum manifold. **WARNING:** Do not use on manifold with "angle-mounted" carburetor



717-2

SEALING PLATE

Spread Bore to Square Bore Flange Part # 9006

1/16" height, Allows a square bore carburetor to mount directly to a spread bore manifold with dual bolt pattern and seal properly



7460

Universal Carb Install Kit Part # 20-124

The kit contains all the hardware necessary for most installations of a new 4 bbl carburetor including: mounting studs (including an extra long one for securing throttle cable / kickdown cable brackets), washers, nuts, air cleaner stud, vacuum caps, 3 different throttle cable balls, bushing adapter for large hole of throttle lever, air cleaner gasket and base gaskets for square and spread bore carbs.



9006



20-124

HOW TO CHOOSE A CARB
STREET CARBURETORS
SUPERCHARGER CARBURETORS
RACE CARBURETORS
MARINE CARBURETORS
CARB SERVICE PARTS & ACCESSORIES
FUEL INJECTION
THROTTLE BODIES
FUEL PUMPS
INTAKE MANIFOLDS
CYLINDER HEADS
SYSTEMAX
ENGINE DRESS-UP
MERCHANDISING
TECHNICAL INFORMATION
INDEX

HOW TO CHOOSE A CARB
STREET CARBURETORS
SUPERCHARGER CARBURETORS
RACE CARBURETORS
MARINE CARBURETORS
CARB SERVICE PARTS & ACCESSORIES
FUEL INJECTION
THROTTLE BODIES
FUEL PUMPS
INTAKE MANIFOLDS
CYLINDER HEADS
SYSTEMAX
ENGINE DRESS-UP
MERCHANDISING
TECHNICAL INFORMATION
INDEX



26-137

Secondary Adjusting Lever Kit **Part # 26-137**

Allows quick and easy adjustment of secondary throttle blade idle setting of Holley 4150 series mechanical secondary carburetors without having to remove the carburetor from the intake manifold.



A.

Secondary Connecting Rods

A. Model 4160/4010 vacuum secondary connecting rod **Part # 20-53**



B.

B. Model 4150/4010 mechanical secondary connecting rod **Part # 20-54**



C.

C. Model 4175/4011 vacuum secondary connecting rod **Part # 20-55**



D.

D. Model 4150 vacuum secondary connecting rod **Part # 20-65**

Secondary Linkage

E. 1:1 linkage ratio, model 4500 DOMINATOR **Part # 20-5**



E.

F. Progressive linkage, model 4500 DOMINATOR **Part # 20-6**



F.

G. "Soft" progressive linkage, model 4500 DOMINATOR **Part # 20-20**



G.



H.

Pro Series Secondary Linkage **Part # 20-122**

Universal kit provides a bulletproof method of adjusting secondaries on all Double Pumpers, HPs and Ultra HP carbs. Allows user to pick between 1:1 or progressive secondary linkage. Provides infinite adjustment of secondary throttle blades.



20-122

Spark Fitting **Part # 26-59**

H. Spark Fitting - Metering Block 180° style



I.

Throttle Lever & Cruise Control Studs

I. Throttle & cruise control stud (GM) **Part # 20-36**



J.

J. Throttle stud; 7/32" dia **Part # 20-37**



K.

K. Throttle stud; 1/4" dia. **Part # 20-38**



L.

L. Throttle stud; 5/16" dia. **Part # 20-39**



M.

M. Transmission kickdown stud . **Part # 20-40**



N.

N. Throttle & cruise control stud . **Part # 20-64**

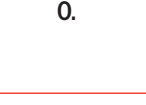

O.

O. Throttle & cruise control stud (Chrysler) **Part # 20-67**

P. Throttle ball assortment **Part # 20-2**



P.



Q.

Throttle Cable Clip
Q. Cable clip **Part # 26-104-10**



R.

Throttle Lever Stud Bushing
R. Stud bushing. **Part # 26-103**



4021

Throttle Linkage Kits
Chevy SB (2x4 tunnel ram/ side-mounted carbs) **Part # 4021**

Chevy BB (2x4 tunnel ram/ side-mounted 4150 carbs) **Part # 4022**

Chevy BB (2x4 tunnel ram/ side-mounted DOMINATOR carbs) **Part # 4032**

Chrysler (2x4 tunnel ram/ side-mounted carbs) **Part # 4023**

Ford 289/302-351C (2x4 tunnel ram/ side-mounted carbs) **Part # 4025**

Ford 429 wedge-460 (2x4 tunnel ram/ side-mounted carbs) **Part # 4027**

Universal (2x4 tunnel ram/ in-line mounted carbs) **Part # 4000**



4000

Throttle Plate Kits
Each kit contains 4 plates & 8 screws

1-7/16" plate diameter, .152" hole size **Part # 26-93**



26-93

1-11/16" plate diameter, Ø hole size **Part # 26-94**



26-94

1-11/16" plate diameter, .093" hole size **Part # 26-95**

1-11/16" plate diameter, .150" hole size **Part # 26-96**

1-3/4" plate diameter, Ø hole size **Part # 26-97**

1-3/4" plate diameter, .100" hole size **Part # 26-98**

1-3/4" plate diameter, .125" hole size **Part # 26-99**

2" plate diameter, Ø hole size . . **Part # 26-100**



20-3

Throttle Shaft Conversion Kits
1:1 linkage ratio, 1-11/16" throttle bore size **Part # 20-3**

Throttle Shaft Service Kits
With Ford A/T kickdown lever; R1850 carburetor **Part # 20-48-1**



20-48-1

With Ford A/T kickdown lever; R3310 carburetor **Part # 20-49-1**

4500 DOMINATOR **Part # 20-104**
(includes primary & secondary shaft)

Throttle Cable Bracket

Chrome throttle cable bracket and throttle return spring installation. Includes dual stainless steel throttle return springs (P/N 20-89). Works on Holley models 4150 and 4160 carburetors (GM only). **Part # 20-88**



20-88

These throttle cable brackets are designed to be used with Holley spread bore model 4165/4175 carburetors. They mount off the back carburetor mounting ear and accept the Chevrolet throttle cable. **Part # 20-32**
Part # 20-44



20-32

Throttle Return Springs (2). **Part # 20-89**

Throttle Solenoid Bracket

Can be used on many Holley aftermarket carburetors. Use with solenoid P/N 46-74. **Part # 20-9**

Used on Holley model 4165/4175 carburetors. Used with solenoid P/N 46-74. . . **Part # 20-47**



20-9

Transmission Kickdown Throttle Linkage **Part # 20-35**

This part will bolt to the throttle lever of a Holley model 4165/4175 carburetor. It will provide an effective mounting point for the transmission kickdown carburetor hookup.



20-35

TH-350 Transmission Kickdown Cable Manifold Bracket. **Part # 20-45**

This bracket is designed to bolt on to a small block Chevrolet V8 intake manifold. It acts as a convenient mounting point for the TH-350 kickdown cable.



20-45

200R4/700R-4 Kickdown Throttle Arm **Part # 20-121**

Corrects geometry on throttle arm for proper shifts and kickdown action includes bolts and instructions



20-121

200R4/TH-700R4 Transmission Kickdown Cable Carb Bracket

This bracket is designed to be used only on Holley model 4150 or 4160 carbs. It bolts on the carb flange ear and provides an effective mounting point for the AOD transmission cable and throttle cable. **Part # 20-95**

For model Holley model 4011 carbs, bolts on the carb flange ear and provides an effective mounting point for the AOD transmission cable and throttle cable **Part # 20-100**



20-95

FORD BRACKETS

Transmission Kickdown Lever Extensions **Part # 20-41**

This handy part is used to extend the Ford O.E. transmission kickdown lever when converting from a 2 bbl to a 4 bbl carburetor.



20-41

Transmission Kickdown Spring & Bracket

The bracket has one mounting hole and a locator pin. For carburetors with a 30cc accelerator pump. **Part # 20-60**



20-60

Bracket has two mounting holes. For carburetors with a 30cc accelerator pump. **Part # 20-91**



20-91

CHRYSLER THROTTLE LEVER EXTENSIONS

Throttle Lever Extension

This part was originally released for use with Holley square flange carburetors, lists R7987 and R8006. It will relocate the throttle lever mounting point for the accelerator cable. . . **Part # 20-14**



20-14

This most popular Chrysler throttle lever extension will install on any Holley square flange carburetor with the universal throttle linkage. It readily accepts the Chrysler throttle lever stud for a simple and convenient throttle hookup. **Part # 20-7**



20-7

UNIVERSAL BRACKETS

Dashpot Bracket

This universal bracket is designed for use with all Holley carburetors that have the universal throttle lever and two threaded bracket mounting holes machined in the throttle body. Use dashpot P/N 11-4 **Part # 20-72**



20-72

This universal bracket is designed for Holley model 4160 carburetors with universal throttle lever and two threaded bracket mounting holes machined in throttle body. Use dashpot P/N 11-4. **Part # 20-58**



20-58

Universal bracket designed for Holley model 4160 carburetors with universal throttle lever. Bracket has one mounting hole and locating pin. Will fit on throttle body that has one machined bracket mounting hole and one "blank" hole. Use dashpot P/N 11-4 **Part # 20-17**



20-17

HOW TO CHOOSE A CARB
STREET CARBURETORS
SUPERCHARGER CARBURETORS
RACE CARBURETORS
MARINE CARBURETORS
CARB SERVICE PARTS & ACCESSORIES
FUEL INJECTION
THROTTLE BODIES
FUEL PUMPS
INTAKE MANIFOLDS
CYLINDER HEADS
SYSTEMAX
ENGINE DRESS-UP
MERCHANDISING
TECHNICAL INFORMATION
INDEX

HOW TO CHOOSE A CARB
STREET CARBURETORS
SUPERCHARGER CARBURETORS
RACE CARBURETORS
MARINE CARBURETORS
CARB SERVICE PARTS & ACCESSORIES
FUEL INJECTION
THROTTLE BODIES
FUEL PUMPS
INTAKE MANIFOLDS
CYLINDER HEADS
SYSTEMAX
ENGINE DRESS-UP
MERCHANDISING
TECHNICAL INFORMATION
INDEX



20-112

UNIVERSAL BRACKETS (Cont'd)

Throttle Cable Bracket - Billet Aluminum . . . Part # 20-112

The perfect finishing touch for street rods, street machines and street/strip cars and trucks. Why go cheap on a throttle return bracket when you can get a good looking, quality piece made of billet aluminum? Let's face it, the throttle cable/return spring bracket is one of the first things your eyes focus on when you lift the hood of any car. You can't help but miss it because it's right out there in the open!

If you're going the route, go the whole way with something that looks good while providing a real measure of safety. This red anodized bracket is multi-adjustable to work on Holley models 4150 and 4160 carburetors. It includes a dual return spring combination that's perched on a uniquely effective mount. Hardware is all stainless steel to stand up to the rigors of time. The Holley name is boldly engraved and provides a very special touch to this outstanding product.



20-119

Dentent Cable Bracket Part # 20-119

Fits Holley (P/N 20-112) billet cable bracket for 4150-4160 carbs. Adjustable to work with TH350, 700R4 200R4



11-4

Universal Dashpot Part # 11-4

Universal dashpot is designed to be used on manual-transmission-equipped vehicles. Its purpose is to prevent engine stalling on sudden deceleration. This dashpot can be used with Holley brackets P/Ns 20-72, 20-58 and 20-17.



46-74

Universal Throttle Solenoid. Part # 46-74

(includes nut 26-57)
This universal solenoid can be used with Holley bracket 4150 & 4160 models P/Ns 20-9 4165 & 4175 models P/Ns 20-47. Also replacement for GM p/n 2060106



26-57

Universal Solenoid & Dashpot Bracket Locknut Part # 26-57

Hex Size: 1.25"; Thread Size: 7/8"-14

CHOKES SERVICE PARTS



45-228

Choke Control Cable (manual) Part # 45-228

The perfect item to complete your purchase of the Holley manual choke conversion kit. Can also be used on all Holley manual choke carburetors (like the Double Pumpers) or any other manual choke carburetor. Cable length is 6 feet



45-229

Choke Control Cable (manual) Mounting Hardware

Universal bracket mounts inside vehicle, under dashboard, to secure control cable. Part # 45-229



45-456

Choke Control Cable (manual) Mounting Hardware

Manual choke cable clamp kit for use only on Holley carburetor models 4010, 4150 and 4160. Mounts on vacuum secondary housing cover. Part # 45-456



45-223

Choke Conversion Kits (Electric & Hot Air)

These kits can be used to convert Holley carburetors which originally came equipped either with a hot air or manually-operated choke to full automatic/electric operation.

Carburetors designed with an "internal vacuum source" such as 0-1850, 0-3310, 0-6425 or 0-7448. Part # 45-223 (standard finish)

Part # 45-223S (shiny finish)



45-224

Carburetors designed with an "external vacuum source" such as 0-4412, 0-4776, 0-4777, 0-4778, 0-4779, 0-4780, 0-4781, 0-6299, 0-6708 and 0-6709 **NOTE:** 4412 requires P/N 45-465 cam lever when using 45-224

electric choke. Part # 45-224 (standard finish)

Part # 45-224S (shiny finish)



45-226

Carburetors originally designed with a integral hot air choke; converts to electric. Part # 45-226

Dechoke linkage for 45-224 (required for 4412 2bbl). Part # 45-465



45-225

Choke Conversion Kit (Manual)

All the parts required for a fast, easy changeover to hand choke operation. For all carburetor models 2300, 4150 and 4160 carburetors with choke hardware mounting bosses on side of main body. Part # 45-225 (standard finish)

Part # 45-225S (shiny finish)



45-377

Choke Thermostat Cap Retainer Kits Part # 45-377

Used on Holley carburetor models 2300, 4150 and 4160.

**Electro-Dyn
Heat Sensor Part # 45-267**

This sensor allows the choke to automatically speed up or slow down its operation by sensing intake manifold and engine block heat.



45-267

Fast Idle Cam Part # 45-376

Used on Holley carburetor models 4150 and 4160.



45-376

**Fast Idle Cam Plate -
Chrome Part # 34-506**

Used on Holley carburetor models 4010, 4011, 4150 and 4160. Originally equipped with metal housing



34-506

Miscellaneous Choke Parts

Used on Holley carburetor models 4150 and 4160.

Choke rod Part # 45-520

Choke plate Part # 45-458

Choke shaft - metal (.317 dia.) Part # 45-457



45-520



45-458



45-457

Replacement Electric Choke Caps

models 4165, 4175 and 4360. Part # 45-230

Carburetor models 2300, 4150, 4160, 4010 and 4011. Also for Holley choke conversion kits P/Ns 45-223, 45-224, 45-226, 45-449, 45-450 and 45-459. Part # 45-258



45-258

Carburetor Main Body Retrofit Kits

This retrofit main body kit converts 0-4777 (650 CFM), 0-4778 (700 CFM) and 0-4779 (750 CFM) shiny or dichromate carburetors to a 750 CFM HP main body for increased horsepower, torque and airflow. Eliminates choke tower and associated hardware of standard Holley Double Pumper. Reduces turbulence and smoothes air entry into the venturi. Pre-calibrated at the factory for optimum performance and drivability on a wide variety of applications. Includes assembled main body with adjustable screw-in air bleeds, down-leg boosters, accelerator pump shooters, vent tubes, carb to baseplate gasket, 2 metering block gaskets, 2 float bowl gaskets, 8 bowl screw gaskets and main jets to properly calibrate carb for street or strip

HP main body retrofit kit (shiny) Part # 134-300S^(B)

HP main body retrofit kit (classic dichromate) Part # 134-300C^(B)



134-300S

FUEL FILTERS

VoluMAX® Fuel Filters

VoluMAX® Fuel filters have a very high flow capacity & feature a washable stainless steel, 60- micron filter element. The two-piece black anodized billet aluminum housing is CNC machined and can be rotated 360° to accommodate any required port alignment. A 3/8" mounting stud with lock washer and nut is provided to mount on your bracket.



162-515

Single inlet/outlet (-8 AN O-ring fittings) Part # 162-514

Dual inlet/outlet (-8 AN O-ring fittings) Part # 162-515



162-517

This filter features a tube-style design. It holds a very fine 7 micron paper element that's capable of filtering up to 750 gallons of fuel an hour. The filter is constructed of .150" wall aluminum tubing with an outer diameter of 2.5" and a length of 10". Removable end caps have AN pipe threads and are sealed with an O-ring. The caps have female 1/2" pipe threads so any fitting can be installed. The filter is anodized for appearance and protection against corrosion. Part # 162-517



162-516

Replacement filter element for VoluMAX fuel filter. The fine 60 micron stainless steel screen is washable. One per package. Part # 162-516



162-518

Replacement paper filter element for 162-517 fuel filter. Part # 162-518

FUEL FILTERS & ELEMENTS

**Carburetor Fuel Inlet
Brass Filter. Part # 162-500**

Moraine fuel inlet filter is brass and fits Holley 4-bbl carburetors with center-hung-style float bowls. Also is a stock replacement for Rochester Quadra-Jet carburetors. 2 per package



162-500

In-line Filters

Hose size: 3/8" Chrome finish. Part # 162-523

Hose size: 5/16" Chrome finish. Part # 162-524



162-523

HOW TO CHOOSE A CARB
STREET CARBURETORS
SUPERCHARGER CARBURETORS
RACE CARBURETORS
MARINE CARBURETORS
CARB SERVICE PARTS & ACCESSORIES
FUEL INJECTION
THROTTLE BODIES
FUEL PUMPS
INTAKE MANIFOLDS
CYLINDER HEADS
SYSTEMAX
ENGINE DRESS-UP
MERCHANDISING
TECHNICAL INFORMATION
INDEX



Fuel Inlet Fitting
For center hung fuel bowl, aluminum red anodized
Size: 7/8-20 to -6AN **Part # 26-73**



For center hung fuel bowl, aluminum red anodized
Size: 7/8-20 to -8AN **Part # 26-74**



For side hung fuel bowl, aluminum red anodized
Size: 9/16-24 to -6AN **Part # 26-75**



Adapter Fitting Part # 26-77
Holley Adapter Fittings are used to help plumb your carburetor from your fuel pump, regulator, or fuel log. Size: 3/8 NPT to -6 AN Straight.



Fuel Inlet Plug
Aluminized red anodized
Size: 7/8-20 **Part # 26-76**



Steel
Size: 7/8-20 2 per pkg. **Part # 26-18-2**



Inverted Flare Fittings
Inverted Flare Fitting, Tube: 3/8", Thread:
7/8-20 (A) x 5/8-18 (B) **Part # 26-26**



Inverted Flare Fitting, Tube: 5/16", Thread:
7/8-20 x 1/2-20 **Part # 26-27**



Inverted Flare Fitting, Tube: 5/16", Thread:
9/16-24 x 1/2-20 **Part # 26-71**

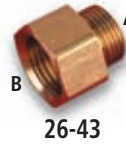

Inverted Flare Fitting, Tube: 5/16", Thread:
7/16-20 x 1/2-20 **Part # 26-86**



Inverted Flare Fitting, Tube: 3/8", Thread: 9/16-24
(A) x 5/8-18 (B) **Part # 26-43**



Standard Fittings
Standard Fitting, Hose: 3/8",
Thread: 9/16-24 (A) **Part # 26-29**



Standard Fitting, Hose: 5/16",
Thread: 9/16-24 (A) **Part # 26-24**



Swivel Fitting, Hose: 5/16",
Thread: 9/16-24 **Part # 26-25**



Standard Fitting (90°), Hose: 5/16",
Thread: 1/2-20 **Part # 26-44**



Fittings for Fuel Pressure Gauges Part # 26-69
Fuel Pressure Gauge Fitting, 90° male elbow



Fuel Line Fitting Part # 26-70
Fuel Line Adapter, Connect a 3/8" fuel line to a
5/16" fuel line



Fitting Gaskets
Fuel bowl inlet fitting gasket,
Size: 9/16" **Part # 108-1**



Fuel bowl inlet fitting gasket,
Size: 7/8" **Part # 108-8**



Fuel bowl inlet fitting gasket,
Size: 7/8" - Nylon **Part # 26-102**

Floats for Holley 2-bbl and 4-bbl performance carburetors come in two basic designs: side hung and center hung. A "side hung float" is so-called because the float arm is attached to the side of the float and it's hung or pivoted from the side of the float bowl. A "center hung float" has its float arm attached to the float center and it's hung or pivoted from the center of the float bowl.

The float material used in any particular carburetor is very often dependent on the carburetor usage. For example, carburetors designed to run on alcohol must use a brass float: carburetors set up for "blow-through" forced induction systems need to use nitrophenyl floats; carburetors used on a "draw-through" forced induction system could use either a brass or a nitrophenyl float. Today, Holley float designs are manufactured in only brass or nitrophenyl, and they are interchangeable, except on secondary 4160 w/ brass center hung floats.

Most Holley performance carburetors have externally-adjustable floats. This feature greatly facilitates one's ability to help keep the carburetor in perfect tune.



116-4



116-3



20-105



116-10



116-15



116-13

Side Hung Float

- Nitrophenyl (adjustable) Part # 116-1
- Nitrophenyl (non-adjustable). Part # 216-43
- Brass Part # 116-4

Center Hung Float

- Brass Part # 116-2
- Nitrophenyl Part # 116-3

Float Hanger Hardware Kit

Includes fuel bowl hardware for float installation Part # 20-105

Notched Float Hardware Kits

A notched float is an absolute necessity when using main jet extensions! This factory, center hung nitrophenyl float is designed with "notches" to clear main jet extensions. This allows the float to operate normally without the possibility of interference from the extensions.

- Notched float with two main jet extensions Part # 116-10
- Notched float without main jet extensions Part # 116-11

4360 models Part # 116-6

Wedged Floats NEW

A wedged float is a necessity for the circle racer. The wedge is designed so that when you are in a turn, and the fuel has sloshed up the side of the bowl, the fuel will ride up the wedge and allow the float to stay open and not close off prematurely. Holley's new wedged floats also feature a new reinforced float bracket assembly that allows more fuel to flow thru the bracket especially when using a bottom feed needle and seat. Made from Nitrophenyl®, the new Holley wedged floats weigh in at approximately 12.8 to 13.2 grams and are available as a primary float, secondary float with notches for jet extensions and a secondary float with notches that includes the jet extensions.

- Primary wedged float Part # 116-13
- Secondary wedged float without main jet extensions Part # 116-14
- Secondary wedged float with main jet extensions. Part # 116-15

HOW TO CHOOSE A CARB
STREET CARBURETORS
SUPERCHARGER CARBURETORS
RACE CARBURETORS
MARINE CARBURETORS
CARB SERVICE PARTS & ACCESSORIES
FUEL INJECTION
THROTTLE BODIES
FUEL PUMPS
INTAKE MANIFOLDS
CYLINDER HEADS
SYSTEMAX
ENGINE DRESS-UP
MERCHANDISING
TECHNICAL INFORMATION
INDEX



34-2

Fuel Bowl Conversion Kit Part # 34-2

Fits model 4150/4160 single pump carburetors. Converts a carburetor equipped with single inlet, side-hung style fuel bowls, with transfer tube, to dual inlet center-hung fuel bowls. Dual inlet bowls can be plumbed from either side.



134-101

Replacement Fuel Bowl Kits

Replacement primary fuel bowl. Side-hung-float style with provision for transfer tube and accelerator pump. Used on model 4160 carburetors. (for adjustable needle & seat) **Part # 134-101** (standard finish)
Part # 134-101S (shiny finish)



134-103

Replacement secondary fuel bowl. Side-hung-float style with transfer tube provision only (for adjustable needle & seat). **Part # 134-105** (standard finish)
Part # 134-105S (shiny finish)



134-104

Replacement primary fuel bowl. Center-hung-float style with provision for accelerator pump and fuel inlet. Used on 3310 and double pump carburetors. **Part # 134-103** (standard finish)
Part # 134-103S (shiny finish)



134-102S

Replacement secondary fuel bowl. Center-hung-float style with provision for accelerator pump and fuel inlet. Used on double pump carburetors. **Part # 134-104** (standard finish)
Part # 134-104S (shiny finish)



134-102S

Replacement secondary fuel bowl. Center-hung-float style with fuel inlet provision only. **Part # 134-102** (standard finish)
Part # 134-102S (shiny finish)



134-108

Replacement primary fuel bowl. Standard finish. Center-hung-float style with provision for dual fuel inlets. Used on DOMINATOR carburetors. **Part # 134-108** (standard finish)



134-112

Replacement secondary fuel bowl. Standard finish. Center-hung-float style with provision for accelerator pump and dual fuel inlets. Used on DOMINATOR carburetors. **Part # 134-112** (standard finish)



134-281

Replacement Fuel Bowl Kits (Cont'd)

Replacement primary fuel bowl for 0-1850 & 0-80457 with non-adjustable needle & seat. **Part # 134-281** (standard finish)
Part # 134-281S (shiny finish)



134-281S

Replacement secondary fuel bowl for 0-1850 & 0-80457 with non-adjustable needle & seat **Part # 134-282** (standard finish)
Part # 134-282S (shiny finish)



134-282

Replacement primary fuel bowl. Side-hung-float style with provision for side fuel inlet off the front face of the bowl. Does not have vent provision. Used on models 4165 and 4175 spread bore carburetors **Part # 134-110** (standard finish)



134-282S

MARINE Fuel Bowls

Used on Holley model 2300 two-barrel carburetors. This is a side-hung float design that accepts only the non-adjustable-style needle and seat assembly. The fuel inlet fitting is located off the side wall of the bowl. (front inlet) . . . **Part # 34R10935AQ**



134-110



34R10935AQ

Used on some Holley model 4160 carburetors. This primary bowl is a side-hung float design, with transfer tube provision, that accepts only the non-adjustable-style needle and seat assembly. The fuel inlet fitting is located off the side wall of the bowl. (front inlet) **Part # 34R10918AQ**



34R10918AQ

Used on some Holley model 4160 carburetors. This primary bowl is a side-hung float design, with transfer tube provision, that accepts only the non-adjustable-style needle and seat assembly. The fuel inlet fitting is located off the side wall of the bowl. (side inlet) **Part # 34R7800-3AMQ**



34R7800-3AMQ

Used on Holley model 4160 carburetors. This secondary bowl is a side-hung float design, with transfer tube provision, that accepts only the non-adjustable-style needle and seat assembly. **Part # 34R5972AQ**



34R5972AQ

Used on Holley model 4160 carburetors. This primary bowl is a side-hung float design, with transfer tube provision. It only accepts the adjustable-style needle and seat assembly. The fuel inlet is located off the side wall of the bowl. (side inlet) **Part # 134-101** (standard finish)
Part # 134-101S (shiny finish)



Fuel Bowl Screws

Long **Part # 26-124**
Short **Part # 26-125**

Aluminum V-Bowls with Clear Sight Glass

Primary fuel bowl, center-hung float style with provisions for accelerator pump and fuel inlet **Part # 134-71S**

Secondary fuel bowl, center-hung float style with provisions for fuel inlet only. Used on vacuum secondary carbs. **Part # 134-72S**

Secondary fuel bowl, center-hung float style with provisions for accelerator pump and fuel inlet **Part # 134-73S**



Fuel Bowl - Quick Change Jet Kits

Cool your jets! Getting hot under the collar when jet-changing can now be a thing of the past. Holley makes it easy with a "quick change jet kit". Designed for the center-hung-style "race" fuel bowl, the kit will allow you to change jets without having to remove the fuel bowl. Simply unscrew the jet "plugs" which thread into the bowl and use the Holley jet tool to remove the old jet. Screw in the new jets, replace the plugs, and you're ready to ride.

Holley quick change jet kits come complete, ready for installation. They include the quick change fuel bowls, gaskets, washers, seals, fuel bowl plugs and jet tool. Everything that you need for an easy conversion. "Quick Change". A new standard of convenience from Holley.

Model 4500 DOMINATOR carburetors. Primary and secondary dual inlet fuel bowls **Part # 34-24** (standard finish)
Part # 34-508 (chrome finish)

Model 4150/4160 carburetors. Primary fuel bowl with single fuel inlet. **Part # 34-25** (standard finish)
Part # 34-509 (chrome finish)

Model 4150 carburetors. Secondary fuel bowl with single fuel inlet and accelerator pump **Part # 34-26** (standard finish)
Part # 34-510 (chrome finish)

Model 4150 carburetors. Secondary fuel bowl with single inlet and no accelerator pump **Part # 34-27** (standard finish)
Part # 34-511 (chrome finish)

Service Parts

Replacement jet removal tool. . . **Part # 26-68**
Fuel bowl plug gasket (10) . . . **Part # 108-77**
Fuel bowl plug (2) **Part # 26-85**



34-509



34-27



26-68



26-85

Chrome Fuel Bowl Kits

Side hung float design, single pump, single inlet with transfer tube provision . . . **Part # 34-500**

Center hung float design, single pump. **Part # 34-501**

Center hung float design, double pump. Will not work on lists 0-6708, 0-6709, 0-7010. **Part # 34-502**



34-500

Fuel Bowl Kits with Sight Windows

Holley's fuel bowl sight plug window kits will enable you to eyeball the carburetor's fuel level without ever having to remove another sight plug. No muss, no fuss, no mess. Fuel bowls come polished.

Single inlet fuel bowl. Contains primary and secondary bowls (v-bowl).. **Part # 34-37**

Dual inlet fuel bowl. Contains primary and secondary bowls (HP & HPDominator v-bowl) **Part # 34-38**

Sight window service part . . . **Part # 26-112**



Fuel Bowl Screw Gasket Kits

Standard replacement paper gasket. **Part # 108-2-20**

Reusable nylon gasket. **Part # 108-98-10**



108-98-10



26-13

Fuel Bowl Sight Plug & Gasket Kits

Standard replacement. **Part # 26-13**

Replacement see-thru sight plug with O-ring seal **Part # 26-113**



26-113

Fuel Bowl Vent Screen

Helps to prevent fuel from spilling out of the fuel bowl vent tubes. . . . **Part # 26-39**

Fuel Bowl Vent Baffle/Whistle

Designed to be used only with the center-hung style float bowl. They act to prevent fuel from splashing out the vent tube . . **Part # 26-89** (1-7/16" length)



26-39

Fuel Transfer Tubes

Carb models 4150 & 4175 . . . **Part # 26-114**

Carb models 4160. **Part # 26-115**

Carb models 4165. **Part # 26-116**



26-115

Fuel Transfer Tube Seals

Works on old-style transfer tubes 2/pkg o-ring . . . **Part # 26-37**

Replacement Viton seal for new-style transfer tube **Part # 108-97**



108-97

Fuel Bowl Vent Tubes

Replacement vent tube with angle cut (10 pack) **Part # 26-107-10**



26-107-10

Fuel Line Selection Chart



	APPLICATION	CARBURETOR NUMBERS	DESCRIPTION
	4150/4150HP Models with 7/8-20 threads Center to Center = 9.25"	Fits popular list numbers such as 0-4776, 0-4777, 0-4778, 0-4779, 0-80575, 0-80529-1 and the Street Avenger series etc.	-8AN O-ring port inlet. Tapped for 1/8" NPT pressure gauge 3/8" NPT female inlet. Tapped for 1/8" NPT pressure gauge -6AN male inlet -6AN Male on both ends -8AN Male Inlet -8AN Male on both ends
	4150/4150HP Models with 5/8-18 inverted flare fuel fittings Center to Center = 9.25"	Fits popular list numbers such as 0-4776, 0-4777, 0-4778, 0-4779, 0-80575, 0-80529-1 and the Street Avenger series etc.	5/8-18 NPT female inlet. Tapped for 1/8" NPT pressure gauge
	4160 Models with 5/8-18 inverted flare fuel fittings Center to Center = 8.80"	Fits Popular list numbers such as 0-3310, 0-80508, etc	5/8-18 NPT female inlet. Tapped for 1/8" NPT pressure gauge
	4500 Model Dominators with 7/8-20 threads Center to Center = 11.25"	Fits popular list numbers such as 0-8082-1, 0-8896-1, 0-80586, 0-9375-1, 0-9377-1 etc.	-8AN O-ring port inlet. Tapped for 1/8" NPT pressure gauge 3/8" NPT female inlet. Tapped for 1/8" NPT pressure gauge -6AN male inlet -6AN Male on both ends -8AN Male Inlet -8AN Male on both ends
	4500 Models with 5/8-18 inverted flare fuel fittings Center to Center = 11.25"	Fits popular list numbers such as 0-8082-1, 0-8896-1, 0-80586, 0-9375-1, 0-9377-1 etc.	5/8-18 NPT female inlet. Tapped for 1/8" NPT pressure gauge
	Universal Fits 4160, 4150, and 4500 models with dual inlet bowls and 7/8-20 Threads		3/8" NPT female inlet. Tapped for 1/8" NPT pressure gauge
	Universal Fits 4150, 4500 models with 7/8 -20 threads		-8 male inlet. 3/8" NPT outlet at rear of log.
	Universal Fits 4160, 4150, and 4500 models with 5/8-18 Threads		1/4" NPT female inlet. Tapped for 1/8" NPT pressure gauge
	Universal Fits 4010, 4011 models		1/4" NPT female inlet. Tapped for 1/8" NPT pressure gauge



CHROME	BENT TUBE	SWIVEL SEAL™	B-NUT DISASSEMBLY SWIVEL SEAL™	BLACK ANODIZED BILLET
-	103175ERL	-	-	-
-	103176ERL	-	-	-
-	-	101175ERL	101185ERL	-
-	-	101176ERL	101186ERL	-
-	-	101275ERL	101285ERL	-
-	-	101276ERL	101286ERL	-
34-150	-	-	-	-
34-160	-	-	-	-
-	-	-	-	-
-	-	-	-	-
-	-	-	102185ERL	-
-	-	-	102186ERL	-
-	-	102275ERL	102285ERL	-
-	-	102276ERL	102286ERL	-
34-550	-	-	-	-
-	105175ERL	-	-	-
-	-	-	-	34-39
34-1	-	-	-	-
34-16	-	-	-	-

Chrome fuel lines for Holley 2010 & 2300



34-21

Universal 180°. Features 3/8" hose end and 5/8-18 inverted flare fitting



34-22

Universal 90°. Features 3/8" hose end and 5/8-18 inverted flare fitting

HOW TO CHOOSE A CARB
STREET CARBURETORS
SUPERCHARGER CARBURETORS
RACE CARBURETORS
MARINE CARBURETORS
CARB SERVICE PARTS & ACCESSORIES
FUEL INJECTION
THROTTLE BODIES
FUEL PUMPS
INTAKE MANIFOLDS
CYLINDER HEADS
SYSTEMAX
ENGINE DRESS-UP
MERCHANDISING
TECHNICAL INFORMATION
INDEX



108-4

Air Cleaner Gasket . . . Part # 108-4
Diameter: 5"
Thickness: .060"
Quantity: 3/pkg

Air Cleaner Gasket . . . Part # 108-62
Diameter: 5"
Thickness: .200"

Air Cleaner Gasket . . . Part # 108-73
Diameter: 7"
Thickness: .060"



108-71

Air Cleaner Gasket . . . Part # 108-71
Diameter: "D"-shaped
Application:
3x2 Carburetors
Quantity: 3/pkg



108-9

Base Gasket Part # 108-9
Model: 2010 and 2300
Bore Size: 1-13/16"
Thickness: .060"



108-52

Base Gasket and Studs . Part # 108-52
Model: 2010 and 2300
Bore Size: 1-1/2"
Thickness: .250"



108-51

Base Gasket and Studs . Part # 108-51
Model: 4150, 4160 and 4180
Bore Size: 1-9/16"
Thickness: .260"



108-58

Base Gasket Part # 108-58
Model: 4150, 4160 and 4180
Bore Size: 1-9/16"
Thickness: .204"



108-18

Base Gasket Part # 108-18
Model: 4010, 4150 and 4160
Bore Size: 1-3/4"
Thickness: 5/16"



108-12

Base Gasket and Studs . Part # 108-12
Model: 4010, 4150 and 4160
Bore Size: 1-3/4"
Thickness: 5/16"



108-10

Base Gasket Part # 108-10
Model: 4150 and 4160
Bore Size: 1-13/16"
Thickness: 1/16"

Base Gasket Part # 108-76
Model: 4150 and 4160
Bore Size: 1-13/16"
Thickness: 5/32"



108-25

Base Gasket
Model: 4165 and 4175
Bore Size: 1-1/2" pri
2" sec, Part # 108-25
1-3/8" pri
2" sec Part # 108-118
Thickness: 1/4"



108-84-2

Base Gasket Part # 108-84-2
Model: 4500 and 4500 DOMINATOR HP, 2 per pkg. open style. Thickness: 1/16"

Base Insulator (Phenolic) . Part # 108-37
Model: 4011, 4165 and 4175
Bore Size: 1-3/8" primary, 2-3/8" secondary
Thickness: 5/8"



108-99

Base Gasket Part # 108-99
Model: 4500 Dominator HP, 4 hole style
Thickness: .060"



108-115

Base Gasket Part # 108-115
Model: Split Dominators (4 pack)
Lists: 0-80585, 0-80590, 0-80600



108-20

Base Plate Part # 108-20
Model: Rochester, Quadra-Jet
Bore Size: 1-3/8" primary, 2-3/8" secondary
Thin stainless steel



108-77

Fuel Bowl Plug Gasket - Quick Change Part # 108-77
All Holley quick change fuel bowls

Fuel Bowl Screw Gasket . Part # 108-2-20

All Holley fuel bowl screws, 20/pkg



108-2-20

Heat Shield Part # 108-70

Model: 4010, 4150 and 4160



108-70

Transfer Tube O-Ring "old style" Part # 26-37

Use with fuel transfer tube P/N 26-19, P/N 26-20 and P/N 26-21

Transfer Tube Seal "new style" Part # 108-97

Use with fuel transfer tube P/N 26-114, P/N 26-115 and P/N 26-116



108-97

Vacuum Passage Gasket – Cork Part # 108-67-20

Seals vacuum passages to vacuum secondary and automatic choke housings, 20/pkg



108-67-20

Throttle Body Gasket . . Part # 108-40

Model: 2300 carburetor List R4412. (single)



108-40

Throttle Body Gasket . . Part # 108-74

Model: 2300 carburetor List R7448 (single)



108-74

Throttle Body Gasket . . Part # 108-61

Models 4150/4160 carburetors (single)
Bore Size:
1-7/16" x 1-7/16"

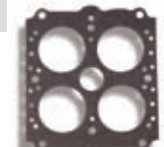

108-61

Throttle Body Gasket . . Part # 108-3

Models 4150/4160 carburetors (single)
Bore Size:
1-9/16" x 1-9/16"

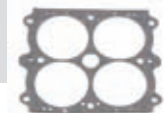

108-7

Throttle Body Gasket . . Part # 108-5

Models 4150/4160 carburetors (single)
Bore Size:
1-11/16" x 1-11/16"

Throttle Body Gasket . . Part # 108-57

Models 4180 carburetor (single)



108-92-2

Blue Non-Stick Fuel Bowl Gasket Part # 108-92-2

For model 4165 and some 4150/4160 (primary side) & 2300. Primary bowl gasket for 4175, except computer-controlled. Available in 2/pkg or bulk orders of 100 or more



108-83-2

Blue Non-Stick Fuel Bowl Gasket Part # 108-83-2

Models 2300, 4150/60 & 4500 two circuit carbs. Available in 2/pkg or bulk orders of 100 or more



108-28-2

Metering Block Gasket . Part # 108-28-2

Primary metering block gasket for Model 4160 Chrysler applications beginning in 1968. Available in 2/pkg or bulk orders of 100 or more



108-34-2

Metering Block Gasket . Part # 108-34-2

For Model 4160, list 0-6270-1 for 340 Chrysler Available in 2/pkg or bulk orders of 100 or more



108-35-2

Metering Block Gasket . Part # 108-35-2

For Model 2300, list 6425, 650 CFM two barrel Available in 2/pkg or bulk orders of 100 or more



108-100

Metering Block Gasket . Part # 108-100

3-circuit Model 4150 competition carburetor

Metering Block Gasket . Part # 108-36-2

Primary & Secondary metering block gasket for Model 4500's w/ intermediate systems, Available in 2/pkg or bulk orders of 100 or more



108-36-2

HOW TO CHOOSE A CARB
STREET CARBURETORS
SUPERCHARGER CARBURETORS
RACE CARBURETORS
MARINE CARBURETORS
CARB SERVICE PARTS & ACCESSORIES
FUEL INJECTION
THROTTLE BODIES
FUEL PUMPS
INTAKE MANIFOLDS
CYLINDER HEADS
SYSTEMAX
ENGINE DRESS-UP
MERCHANDISING
TECHNICAL INFORMATION
INDEX

HOW TO CHOOSE A CARB
STREET CARBURETORS
SUPERCHARGER CARBURETORS
RACE CARBURETORS
MARINE CARBURETORS
CARB SERVICE PARTS & ACCESSORIES
FUEL INJECTION
THROTTLE BODIES
FUEL PUMPS
INTAKE MANIFOLDS
CYLINDER HEADS
SYSTEMAX
ENGINE DRESS-UP
MERCHANDISING
TECHNICAL INFORMATION
INDEX



108-55-2

Metering Block Gasket . Part # 108-55-2
Primary metering block gasket for Model 4180 Part # **8R1915**
Available in 2/pkg or bulk orders of 100 or more.



108-89-2

Blue Non-Stick Metering Block Gasket . . Part # 108-89-2
For most Model 4150's, some 4160's early 4165's . . Part # **8R1907-1**
& most 2300's Secondary metering block gasket on double pumpers. Not used w/ accelerator pump transfer tube. Used on 4500's w/o intermediate idle system. Available in 2/pkg or bulk orders of 100 or more.



108-90-2

Blue Non-Stick Metering Block Gasket . . Part # 108-90-2
Used as a secondary bowl & metering plate gasket on many 4160's & 4175's Part # **8R1908-1**
Available in 2/pkg or bulk orders of 100 or more.



108-91-2

Blue Non-Stick Metering Block Gasket . . Part # 108-91-2
Used as primary & secondary metering block gaskets on 4165/75 & a few 4150 carburetors. Used on primary side of some 4160's Used on same carburetors as 108-29 when equipped w/ accelerator pump transfer tube. Not interchangeable with 8R1907 or 108-89-2. Available in 2/pkg or bulk orders of 100 or more.



108-121

Blue Non-Stick Metering Block Gasket . . Part # 108-121
Primary & Secondary metering block gasket for Model 4500's w/ intermediate systems, Available in 2/pkg or bulk orders of 100 or more



108-200

These **gasket assortments** have been selected to cover popular Holley four barrels. Each contains the quantities of gaskets shown.

PART # 108-200	PART # 108-201	PART # 108-202	PART # 108-203
(2) 108-89	(1) 108-27	(1) 108-27	(2) 108-91
(2) 108-83	(1) 108-89	(1) 108-90	(2) 108-92
	(1) 108-90	(1) 108-91	
	(1) 108-83	(1) 108-92	

Fuel Bowl Gasket Part # 108-56-2
Primary-bowl gasket for Model 4180. Available in 2/pkg or bulk orders of 100 or more. . . . Part # **8R1916**
100 or more.

Fuel Bowl Screw & Gasket Kits

Primary Side (Models 4500, 4175, 4150, 4160) Part # 26-124
Consist of:
(1) 8R1911-1 primary fuel bowl gasket for 2-circuit metering
(1) 8R1910-1 primary fuel bowl gasket models 4165 & 4175
(4) primary fuel bowl screws & (4) 8R657 fuel bowl screw gaskets

Secondary Side (Models 4160 and 4175) Part # 26-125

Consist of:
(1) 8R1908-1 secondary metering body gasket
(4) secondary side fuel bowl screws & (4) 8R657 fuel bowl screw gaskets

Secondary Side (Models 4165) . . Part # 26-126

Consist of:
(1) 8R1910-1 secondary metering body gasket
(4) secondary side fuel bowl screws & (4) 8R657 fuel bowl screw gaskets



26-125

Metering Plate Screws/Gaskets Part # 26-123

This kit contains (6) metering plate screws & (1) each of two styles of metering plate gaskets used in Holley 4160 & 4175 carbs. They are also used on model 2300 carbs used on the outboard side of a tri-power set-up.



108-27-2

Secondary Metering Plate Gasket Part # 108-27-2
For some Model 4160s. same pattern used on metal 1034-1993 metering body plate. Available in 2/pkg or bulk orders of 100 or more. Part # **8R1899**
100 or more



108-13-2

Secondary Metering Plate Gasket Part # 108-13-2
For Model 4160 Chrysler & outboard Model 2300 on some 3 x 2 applications with diaphragm-operated throttles.

Trick Kit®

- One kit services all Holley performance carburetors
- Uses genuine Holley quality service parts
- Extra parts provided for performance tuning (pump cams, squirters, etc.)
- Explicit step-by-step instructions
- Includes detailed tuning guide
- Packaging serves as a handy parts tray
- Designed as a master parts package for the serious tuner



37-933

Fast Kit®

- Five kits service all Holley performance carburetors
- Uses genuine Holley quality service parts
- Explicit step-by-step instructions
- Includes detailed tuning guide
- Packaging serves as a handy parts tray
- Competitively priced
- Ideal for a quick carburetor freshening



37-1542

Renew Kit®

- Eleven kits service all Holley performance carburetors
- Uses genuine Holley quality service parts
- Explicit step-by-step instructions
- Includes detailed tuning guide
- Packaging serves as a handy parts tray
- Competitively priced
- Includes small parts for a complete detailed rebuild



37-119

Note: Photos may not be representative of complete kit.

HOW TO CHOOSE A CARB
STREET CARBURETORS
SUPERCHARGER CARBURETORS
RACE CARBURETORS
MARINE CARBURETORS
CARB SERVICE PARTS & ACCESSORIES
FUEL INJECTION
THROTTLE BODIES
FUEL PUMPS
INTAKE MANIFOLDS
CYLINDER HEADS
SYSTEMAX
ENGINE DRESS-UP
MERCHANDISING
TECHNICAL INFORMATION
INDEX

Holley Trick Kit® Part # 37-933

When your Holley performance carburetor is due for a performance rebuild, it's time to get the Holley Trick Kit®, P/N 37-933. This Holley Trick Kit® contains all the parts that you'll need to perform a complete carburetor rebuild on your Holley vacuum secondary or double pump carburetor. Plus it's got extra parts related to carburetor calibration that are required to accomplish a real performance tune. These include accelerator pump discharge nozzles, accelerator pump cams, vacuum secondary springs and extra gaskets. A carburetor exploded view and a detailed tuning guide is also included. The packaging serves as a handy parts tray. This Holley Trick Kit® has it all.

R1848-1	R4056-1	R4776-1	R4779-8	R6129	R6772	R7410	R8879	R9976	R80453	R80535-1	R80781
R1849	R4118	R4776-2	R4780	R6210-1	R6773	R7411	R8896	R80095	R80454	R80540	R80783
R1850-2	R4144-1	R4776-3	R4780-1	R6210-2	R6774	R7413	R8896-1	R80098	R80457	R80541	R80870
R1850-3	R4224	R4776-4	R4780-2	R6210-3	R6853	R7448	R9002	R80099	R80457-1	R80542	R81570
R1850-4	R4235	R4776-5	R4780-3	R6211	R6895	R7855	R9040	R80111	R80457-2	R80555	R81670
R1850-5	R4236	R4776-6	R4780-4	R6211-1	R6909	R7985	R9188	R80112	R80460	R80556	R81770
R2818-1	R4295	R4777	R4780-5	R6212	R6910	R7986	R9210	R80120	R80496	R80570	R81850
R3124	R4296	R4777-1	R4780-6	R6213	R6919	R7987	R9219	R80128	R80496-1	R80572	R82750
R3247	R4346	R4777-2	R4781	R6238-1	66979	R8004	R9254	R80133	R80497	R80573	R82751
R3310-1	R4365-1	R4777-3	R4781-1	R6239-1	R6979-1	R8005	R9375	R80134	R80498	R80574	R83310
R3310-2	R4412	R4777-4	R4781-2	R6262	R6989	R8006	R9375-1	R80135	R80498-1	R80575	R83310-1
R3310-3	R4412-1	R4777-5	R4781-3	R6270-1	R7001	R8007	R9377	R80136	R80507	R80576	R83311
R3310-4	R4412-2	R4777-6	R4781-4	R6291	R7002-1	R8059	R9377-1	R80137	R80508	R80577	R83312
R3310-5	R4412-3	R4778	R4781-5	R6299-1	R7004-1	R8059-1	R9377-2	R80139	R80508-1	R80578	R84412
R3310-5	R4452-1	R4778-1	R4781-6	R6464	R7004-2	R8060	R9379	R80145	R80509	R80670	R84776
R3310-6	R4490	R4778-2	R4781-7	R6468-1	R7005-1	R8060-1	R9380	R80155	R80511	R80670-1	R84777
R3367	R4514-1	R4778-3	R4782	R6468-2	R7005-2	R8082	R9381	R80163	R80512	R80672	R84778
R3370	R4548	R4778-4	R4783	R6497	R7006-1	R8082-1	R9645	R80164	R80513	R80673	R84779
R3418	R4555	R4778-5	R4788	R6498	R7006-2	R8082-2	R9646	R80165	R80514	R80674	R84780
R3613	R4575	R4778-6	R4788-1	R6512	R7009-1	R8156	R9647	R80166	R80519	R80675	R84781
R3659	R4609	R4779	R4790	R6520	R7010	R8162	R9776	R80169	R80528	R80676	R87448
R3660	R4628	R4779-1	R4791	R6528	R7053-1	R8181	R9834	R80186	R80528-1	R80770	R89834
R3807	R4647	R4779-2	R4792	R6619-1	R7054	R8276	R9834-1	R80186-1	R80529	R80770-1	R83670
R3810	R4653	R4779-3	R4800-1	R6708	R7154	R8302	R9834-2	R80431	R80529-1	R80776	R83770
R3811	R4670	R4779-4	R4801-1	R6708-1	R7320	R8546	R9837-3	R80432	R80531	R80777	R85670
R3910	R4672	R4779-5	R4802-1	R6709	R7320-1	R8679	R9895	R80436	R80532	R80778	R85770
R4053	R4742	R4779-6	R4803-1	R6710	R7351	R8700	R9923	R80450	R80533	R80779	
R4055-1	R4776	R4779-7	R6109	R6711	R7397	R8804	R9948	R80452	R80535	R80780	

Holley Fast Kit®

Five (5) Holley Fast Kits® cover the entire spectrum of Holley performance carburetors. Holley Fast Kits® include only genuine Holley parts and are also competitively priced. When your Holley is rebuilt using a genuine Holley Fast Kit®, you're assured that original Holley quality is being maintained. Detailed instructions are included. Ideal for a quick refresher of your carburetor.

37-1542

Fits model 4160

R1848-1	R6946-1	R9776
R1849	R6947	R9834
R1851-2	R6979	R9834-1
R1850-3	R6979-1	R9834-2
R1850-4	R6989	R9834-3
R1850-5	R7009-1	R50399
R3310-2	R7053-1	R50399-1
R3310-3	R7154	R80431
R3310-4	R7413	R80432
R3310-5	R7850	R80450
R3310-6	R7985	R80451
R3367	R7986	R80457
R3370	R7987	R80453
R3810	R8004	R80454
R3811	R8005	R80457
R4235	R8006	R80457-1
R4236	R8007	R80457-2
R4452-1	R8181	R80460
R4548	R8207	R80551
R6270-1	R8207	R81850
R6291	R9002	R83310
R6299-1	R9040	R83310-1
R6520	R9210	R83311
R6619-1	R9219	R83312
R6909	R9254	R89834
R6919	R9626	

37-1543

Fits model 2300

R4412
R4412-1
R4412-2
R4412-3
R7448
R9647
R84412
R87448

37-1544

Fits model 4150

R4295	R4779-6	R80573
R4776	R4779-7	R80574
R4776-1	R4779-	R80575
R4776-2	8R4780	R80576
R4776-3	R4780-1	R80576
R4776-4	R4780-2	R80577
R4776-5	R4780-3	R80670
R4776-6	R4780-4	R80670-1
R4777	R4780-5	R80770
R4777-1	R4780-6	R80770-1
R4777-2	R4781	R80776
R4777-3	R4781-1	R80777
R4777-4	R4781-2	R80778
R4777-5	R4781-3	R80779
R4777-6	R4781-4	R80780
R4778	R4781-5	R80781
R4778-1	R4781-6	R80781
R4778-2	R4781-7	R80870
R4778-3	R4781-8	R81570
R4778-4	R4781-9	R81670
R4778-5	R4781-10	R81770
R4778-6	R4781-11	R84776
R4779	R4781-12	R84777
R4779-1	R4781-13	R84778
R4779-2	R4781-14	R84779
R4779-3	R4781-15	R84780
R4779-4	R4781-16	R84781
R4779-5	R4781-17	R84782
	R4781-18	R84783
	R4781-19	R84784
	R4781-20	R84785
	R4781-21	R84786
	R4781-22	R84787
	R4781-23	R84788
	R4781-24	R84789
	R4781-25	R84790
	R4781-26	R84791
	R4781-27	R84792
	R4781-28	R84793
	R4781-29	R84794
	R4781-30	R84795

37-1546

Fits model 4150HP

R80496	R80540
R80496-1	R80540-1
R80497	R80541
R80507	R80541-1
R80507-1	R80542
R80508	R80542-1
R80508-1	R80674
R80509	R80675
R80509-1	R80676
R80511	R80677
R80511-1	R82750
R80512	R82751
R80513	R82651
R80513-1	
R80514	
R80514-1	
R80519	
R80528	
R80528-1	
R80529	
R80529-1	
R80531	
R80535	
R80535-1	

37-1547

Fits model 4500

R4575
R6214
R6464
R7320
R7320-1
R8082
R8082-1
R8082-2
R8896
R8896-1
R9375
R9375-1
R9377
R9377-1
R9377-2
R80186
R80186-1
R80532
R80532-1
R80533
R80533-1
R80556
R80556-1
R80578
R80672
R80673

Holley Renew Kit®

Purchase a Holley Renew Kit® next time a carburetor rebuild is due and you'll be assured of using only genuine Holley factory service parts. This really is the only sure way of knowing that your Holley carburetor will be brought back to original specifications and "like new" condition. The Renew Kit® package includes new gaskets, O-rings, pump diaphragm(s), needle and seat(s), power valve(s), and a detailed instruction sheet to take you step-by-step through the rebuilding process. All the parts and information necessary for a professional rebuild are included. Leave the "guessing" to others. Be assured with Holley brand Renew Kits.

37-119

R1848-1
R1849
R1850-2
R1850-3
R1850-4
R1850-5
R3367
R3370
R4452-1
R4548
R6291
R6520
R6909
R7053-1
R7154
R7413
R9040
R80431
R80432
R80457
R80457-1
R80457-2
R81850

37-1539

R3124
R3247
R3310-1
R3418
R3613
R3910
R4053
R4118
R4346
R4490
R4555
R4575
R4742
R4800-1
R4801-1
R4802-1
R4803-1
R6238-1
R6239-1
R6299-1
R6464
R6708
R6708-1
R6709
R7320
R7320-1
R8082
R8082-1
R8082-2
R8572
R8896
R8896-1
R9029
R9188
R9375
R9375-1
R9377
R9377-1
R9377-2
R9645
R9646

R75010
R75011
R80145
R80159
R80186
R80186-1
R80340
R80340-1
R80436
R80496
R80496-1
R80497
R80498
R80498-1
R80507
R80509
R80511
R80512
R80513
R80514
R80519
R80528
R80528-1
R80529
R80529-1
R80531
R80532
R80533
R80535
R80535-1
R80540
R80541
R80542
R80556
R80672
R80673
R80674
R80675
R80676
R82750
R82751

37-485

R4235
R4236
R4295
R4296
R4776
R4776-1
R4776-2
R4776-3
R4776-4
R4776-5
R4776-6
R4777
R4777-1
R4777-2
R4777-3
R4777-4
R4777-5
R4777-6
R4778
R4778-1
R4778-2
R4778-3
R4778-4
R4778-5
R4778-6
R4779
R4779-1
R4779-2
R4779-3
R4779-4
R4779-5
R4779-6
R4779-7
R4779-8
R4780
R4780-1
R4780-2
R4780-3
R4780-4
R4780-5
R4780-6
R4781
R4781-2
R4781-3
R4781-4

37-605

R6210-1
R6210-2
R6210-3
R6211
R6211-1
R66262
R6468-1
R6468-2
R6497
R6498
R6512
R6528
R6711
R6772
R6773
R6774
R6853
R7054

37-1540

R7454
R7455
R7456
R7555
R7556
R7955
R7956
R7957
R7958
R8001
R8002
R8003
R8149
R8149-1
R8158
R8203
R8204
R8206
R8479
R8516
R8517
R8642
R8677
R8771
R8874
R8914
R8958
R9112
R9162
R9185
R9192
R9192
R9193
R9694
R9777
R9931
R9935
R9973

37-720

R6619-1
R8007
R9013
R9015
R9834
R9834-1
R9834-2
R9834-3
R89834

37-1541

R82010
R82011
R82012
R84010
R84010-1
R84010-2
R84010-3
R84011
R84011-1
R84011-2
R84011-3
R84012
R84012-1
R84012-2
R84012-3
R84013
R84013-1
R84013-2
R84013-3
R84014
R84014-1
R84014-2
R84014-3
R84015
R84015-1
R84015-2
R84015-3
R84016
R84016-1
R84016-2
R84016-3
R84017
R84017-1
R84017-2
R84017-3
R84018
R84018-1
R84018-2
R84020
R84020-1
R84020-2

37-754

R3310-2
R3310-3
R3310-4
R3310-4
R3310-5
R3310-6
R80508
R80508-1
R83310
R83310-1
R83311
R83312

37-1536

R6270-1
R6895
R6919
R6989
R7009-1
R7410
R7411
R7448
R7985
R7986
R7987
R8004
R8005
R8006
R8181
R9002
R9210
R9219
R9254
R9647
R9776
R80095
R80098
R80099
R80111
R80112
R80120
R80133
R80134
R80135
R80136
R80137
R80163
R80164
R80165
R80166
R80450
R80451
R80452
R80453
R80454
R80460
R87448

37-1537

R2818-1
R3659
R3660
R3807
R3810
R3811
R4055-1
R4056-1
R4144-1
R4224
R4365-1
R4514-1
R4609
R4628
R4647
R4653
R4670
R4672
R4782
R4783
R4790
R4791
R4792
R6105
R6106
R6107
R6107-1
R6129
R6212
R6213
R6499
R6710
R6910
R7002-1
R7004-1
R7004-2
R7005-1
R7005-2
R7006-1

37-934

R80570
R80870

37-935

R80670
R80670-1
R80770
R80770-1
R81670

37-936

R80681
R90470
R90670

R7006-2
R7010
R7351
R7397
R7855
R8059
R8059-1
R8060
R8060-1
R8276
R8302
R8546
R8679
R8700
R8879
R9023
R9895
R9923
R9948
R9976
R80128
R80139
R80155
R80169
R80491
R80555



Marine Carb Renew Kits®

Renew Kit® original equipment marine rebuild kits are available for all Holley marine carburetors as well as Carter and Rochester. Each kit contains all parts and gaskets that are necessary to restore "like new" performance to your marine carburetor. Detailed instructions are also included to guide you through the rebuilding process. Start off the season with a quality Holley Renew Kit® marine repair kit. It's your guarantee for trouble-free cruising.

Part #	Holley Marine Carburetors
3-396	R6105, R6105-1, R6106, R6107, R6107-1
3-474	R9011
3-485	R9022, R80427, R80466
3-606	R9023
3-720	R9013, R9015, R80341
3-888	R6150
3-1184	R6361, R8572, R9029, R80159
3-1445	R84018, R84018-1, R84018-2, R84023, R84023-1, R84023-2, R84028, R84038, R84039, R84044, R84044-1
3-1447	R84022, R84022-1, R84024, R84024-1, R84026, R84026-1, R84026-2, R84040, R84040-1, R84041, R84041-1, R84042
37-1539	R75010, R75011, R80340, R80340-1
703-1	R4473, R6151, R6152, R6407, R80551
703-28	R9393, R9394, R9399, R9399-1, R50405, R50405-1, R50418, R50462, R50462-1, R50468, R50468-1, R80262, R80264, R80364
703-29	R50419, R50419-1, R50419-2, R50463, R50463-1, R80265, R80315, R80315-1, R80403, R80403-1, R80473, R80473-1, R80492
703-30	R50417, R50417-1, R50461, R50461-1, R50467, R50467-1, R80263, R80320-1
703-32	R7036
703-33	R7128, R7159, R7163, R8159, R9392, R50464, R50470, R80318-1
703-34	R80310, R80310-1, R80310-2, R80391, R80552
703-35	R80311, R80311-1, R80311-2, R80330, R80330-1, R80444
703-36	R80312, R80312-1, R80402, R80402-1
703-40	R80328, R80328-1, R80328-2

Part #	Holley Marine Carburetors
703-41	R80313, R80313-1, R80316, R80316-1, R80321, R80321-1, R80385
703-45	R80309, R80408
703-46	R80180
703-47	R50469, R50469-1, R80319-1, R80383, R80383-1, R80456-1
703-48	R80378, R80378-1
703-49	R80382, R80382-1, R80382-2, R80386, R80386-1
703-50	R80390
703-51	R82020, R82021, R82028, R82028-1, R82029
703-53	R50483, R50483-1, R84046, R84046-1
703-55	R80434
703-58	R80443
703-59	R84037
703-60	R84050
703-66	R80487 Carter
3-352	4695
3-358	6478
3-588	3213, 3214, 3392, 3543, 3980, 4476, 4699, 6130, 6212
3-592	2955, 3660, 6310 Rochester
3-466	7023080, 7023186, 7023188, 7023189, 7024080, 7024081, 7024187, 7024188
3-539	7020994, 7020996, 7024083, 7024087, 7024089, 7024180, 7024181, 7025183, 7025184, 7025638, 7025662
3-555	7023182, 7024088
3-670	7044187
703-39	17080560, 17080561, 17080563, 17080564, 17080565, 17084516, 17085013



Electric Fuel Pressure Gauge

Features

- Allows you to monitor fuel pressure while driving
- Dash mounting
- Includes sending unit
- Eliminates guesswork helps pinpoint fuel delivery problems
- Easily plumbs near carburetor fuel inlet

Electric Fuel Pressure Gauge Kit 0-15 psi Part # **26-503**

90° elbow to attach to Holley fuel lines Part # **26-69**



26-503

Mechanical Fuel Pressure Gauge

Holley offers two (2) types of mechanical fuel pressure gauges: dry and liquid filled. The "dry" gauges are offered in 0-15 and 0-30 PSI increments and are budget priced but not short on quality. The "liquid filled" gauges are also offered in the 0-15 and 0-30 PSI ranges. They contain a liquid glycerin which dampens the needle movement and makes it more linear in operation. Liquid gauges are premium quality instruments which will give years of service.

Features

- 1 1/2" Diameter
- Chromed steel case
- 1/8" NPT brass fitting
- Includes elbow fitting on non-liquid filled (P/N 26-500 & 26-502 only)
- Fits Holley chromed fuel lines and fuel block

0-15 psi gauge (non-liquid filled) Part # **26-500**

0-30 psi gauge (non-liquid filled) Part # **26-502**

0-15 psi gauge (liquid filled) Part # **26-504**

0-30 psi gauge (liquid filled) Part # **26-505**

90° elbow to attach to Holley fuel line Part # **26-69**



26-504

Vacuum Boost Gauge Part # 90520

Reads 0-30 inches of vacuum and 0-15 lbs. of boost. Fits standard 2-1/16" diameter gauge hole.

Mounting hardware is included.



90520

Vacuum Gauge Part # 26-501

Features

- 2" Diameter
- 0-30 in. HG
- Chromed steel case
- 1/8" NPT brass fitting
- Hose fitting included



26-501

CARBURETOR SMALL PART KITS

Hard-to-find parts are no longer "hard to find" with Holley parts kits. Available carburetor and electric fuel pump small parts kits now eliminate the problem of finding the correct components when rebuilding. The following kits are available:



34-10

Carburetor Small Parts Kit Part # 34-10

This kit consists of a selection of commonly used O-rings, E-rings, C-rings, check balls, washers, cotter pins and rod retainers.



20-124

Universal Carb Install Kit Part # 20-124

The kit contains all the hardware necessary for most installations of a new 4 bbl carburetor including: mounting studs (including an extra long one for securing throttle cable / kickdown cable brackets), washers, nuts, air cleaner stud, vacuum caps, 3 different throttle cable balls, bushing adapter for large hole of throttle lever, air cleaner gasket and base gaskets for square and spread bore carbs.



36-117

Carburetor Small Gasket & Plug Kit Part # 36-117

This kit consists of various small gaskets, plugs and seals for transfer tubes, power valves, vacuum secondary housing, needle and seat hardware and pump discharge nozzles.



36-118

Carburetor Hardware Parts Kit Part # 36-118

This kit consists of carburetor hardware components such as throttle shaft bushings, idle needles, check balls, rods, retainers, screws and plugs.



26-105

Vacuum Cap Assortment Part # 26-105

A selection of different size vacuum tube caps. An indispensable addition to any professional tool kit.

CARBURETOR SMALL PART KITS (cont'd)

**Tuning/Calibration Kit
Double pump carburetors . . . Part # 36-182^(B)**



36-182

This tuning kit contains a selection of main jets, pump nozzles and power valves, in popular sizes, all contained in a handy and durable, compartmentalized plastic case. Ideal for track-side tuning, this kit provides a quick and easy way to accomplish your carburetor tuning with the correct parts. In addition, the parts case allows you to keep parts organized and readily at hand. A handy parts guide is affixed to the inside case cover. Numbers referenced on the parts guide will assist in reordering components when necessary. Gaskets are included to facilitate carburetor reassembly.

The following parts are included:

Qty	Description
4 each of	Eight (8) metering jet sizes ranging from #70 to #84
2	#35 Pump Nozzle
2	#37 Pump Nozzle
1	#35 Power Valve
1	#45 Power Valve
1	#50 Power Valve
12	Metering Block Gaskets
12	Fuel Bowl Gaskets
—	Miscellaneous pump nozzle, power valve and fuel bowl screw gaskets



36-184

**Accelerator Pump Tuning Kit
Holley 2-bbl & 4-bbl
Performance Carburetors . . . Part # 36-184**

This tuning kit is composed of a selection of accelerator pump hardware components including pump diaphragms, pump nozzles, pump cams and related parts. Contained in a convenient plastic parts case, this kit has all that is required to properly tune and calibrate the accelerator pump circuit(s) for your street, drag or circle track car or tow vehicle. A handy parts guide is affixed to the inside case cover to assist in reordering components when necessary.

The following parts are included:

Qty	Description
2 each of	Twelve (12) pump discharge nozzle sizes ranging from .025 to .052
2 each of	Ten (10) accelerator pump cam profiles (colors)
5	50cc GFLT pump diaphragm
5	30cc GFLT pump diaphragm
—	Miscellaneous screws, gaskets, check valves and weights



Alcohol Jets

5/16-32 UNF thread

Holley alcohol jets are specially designed to work only with the following model 4150 HP carburetors: 0-80542 (650 CFM), 0-80535 (750 CFM) and 0-80498 (950 CFM). The unique metering blocks used with these carburetors are designed to accept the physically larger size of this main jet.

There are two (2) jets per package. The following sizes are available:

STANDARD LENGTH	JET NO.	DRILL SIZE
	122-132	.132
	122-136	.136
	122-138	.138
	122-140	.140
	122-142	.142
	122-144	.144
	122-146	.146
	122-148	.148
	122-150	.150
	122-152	.152
	122-154	.154
	122-156	.156
	122-158	.158
	122-160	.160
	122-164	.164
	122-168	.168
	122-172	.172
	122-176	.176
	122-180	.180
	122-184	.184
	122-188	.188
	122-192	.192
	122-196	.196
	122-200	.200

NOTE: Alcohol jet kits are available. A selection of alcohol jet sizes can be ordered under P/N 36-201.

Main Jet Tap Part # 26-1

Used for "cleaning up" main jet threads in the metering block



Emulsion Jets

(6/32 UNF Thread)

P/N	Hole Size
142-00	.000"
142-20	.020"
142-21	.021"
142-22	.0225"
142-24	.024"
142-25	.025"
142-26	.026"
142-28	.028"
142-29	.0292"
142-31	.031"
142-32	.032"
142-33	.033"
142-35	.035"
142-36	.036"
142-37	.037"
142-38	.038"
142-39	.039"
142-40	.040"
142-41	.041"
142-42	.042"
142-43	.043"
142-46	.0465"
142-52	.052"
142-55	.055"
142-59	.0595"
142-62	.0625"
142-64	.0635"
142-67	.067"
142-70	.070"
142-73	.073"
142-76	.076"
142-78	.078"



Standard Main Jets

(1/4-32 UNF Thread)

P/N	Hole Size	P/N	Hole Size
122-40	.040"	122-78	.0870"
122-41	.041"	122-79	.0890"
122-42	.042"	122-80	.0890"
122-43	.043"	122-81	.0920"
122-44	.044"	122-82	.0940"
122-45	.045"	122-83	.0975"
122-46	.0465"	122-85	.0985"
122-47	.047"	122-86	.1000"
122-48	.048"	122-87	.1015
122-49	.048"	122-88	.1025"
122-50	.049"	122-89	.1045"
122-51	.050"	122-90	.1055"
122-52	.052"	122-91	.1085"
122-53	.052"	122-92	.1100"
122-54	.053"	122-93	.1125"
122-55	.054"	122-94	.1155"
122-56	.055"	122-95	.1165"
122-57	.056"	122-96	.1195"
122-58	.057"	122-97	.1210"
122-59	.058"	122-98	.1240"
122-60	.060"	122-99	.1260"
122-61	.060"	122-100	.1285"
122-62	.061"	122-101	.1260"
122-63	.062"	122-102	.1280"
122-64	.064"	122-103	.1300"
122-65	.065"	122-104	.1340"
122-66	.066"	122-105	.1370"
122-67	.0663"	122-106	.1410"
122-68	.0685"	122-107	.1450"
122-69	.0693"	122-108	.1470"
122-70	.0735"	122-109	.1500"
122-71	.0750"	122-110	.1560"
122-72	.0755"		
122-73	.0790"		
122-74	.0800"		
122-75	.0820"		
122-76	.0840"		
122-77	.0855"		

Note: Jet hole sizes provided for reference only. All Holley jets are sized by actual flow and may vary from sizes above.

Air Bleeds



126-55-10

Models 4150 HP and 4500 DOMINATOR HP

Replaceable air bleeds for the idle, intermediate and high speed circuits. All bleeds are #10-32 UNF thread. Note: the "-10" indicates a quantity of ten (10) bleeds per package.

Air Bleed	Drill Size	Air Bleed	Drill Size
126-23-10	.023	126-47-10	.047
126-24-10	.024	126-49-10	.049
126-25-10	.025	126-51-10	.051
126-26-10	.026	126-53-10	.053
126-27-10	.027	126-55-10	.055
126-28-10	.028	126-57-10	.057
126-29-10	.029	126-59-10	.059
126-30-10	.030	126-61-10	.061
126-31-10	.031	126-63-10	.063
126-32-10	.032	126-65-10	.065
126-33-10	.033	126-67-10	.067
126-34-10	.034	126-69-10	.069
126-35-10	.035	126-70-10	.070
126-36-10	.036	126-71-10	.071
126-37-10	.037	126-72-10	.072
126-38-10	.038	126-73-10	.073
126-39-10	.039	126-74-10	.074
126-40-10	.040	126-75-10	.075
126-41-10	.041	126-76-10	.076
126-43-10	.043	126-77-10	.077
126-45-10	.045	126-78-10	.078

Air Bleed Specifications 4150 HP and 4500 DOMINATOR HP

CARBURETOR LIST NO.	IDLE BLEED	INTERMEDIATE BLEED	HIGH SPEED
R7320-1	53	N/A	28
R8082-2	71	N/A	37
R8896-1	53	63	40
R9375	39	N/A	25
R9375-1	53	63	34
R9377-1	40	61	28
R75010	40	61	33
R75011	49	61	28
R80186-1	73	N/A	36
R80340-1	71	N/A	34
R80496	72	N/A	32
R80496-1	74	N/A	32
R80498	55	N/A	30
R80507	73	N/A	OPEN CHANNEL
R80509	72	N/A	32
R80511	73	N/A	33
R80513	75	N/A	25
R80514	73	N/A	32
R80528-1	75	N/A	36
R80529-1	72	N/A	32
R80532	51	61	28
R80533	53	65	36
R80535-1	61	N/A	31
R80540	74	N/A	45
R80541	72	N/A	45
R80542	59	N/A	33
R80556	51	59	31
R80586	28	54	28
R80672	59	51	32
R80673	59	51	31
R80674	72	N/A	45
R80675	75	N/A	36
R80676	68	N/A	32
R80785	72	N/A	32
R82750	75 (primary) 28 (secondary)	N/A N/A	25 36
R82751	71 (primary) 28 (secondary)	N/A N/A	25 36

Air Bleed Assortment Kit Part # 36-240^(B) 4500 DOMINATOR HP and 4150 HP Carburetors

This air bleed kit is a must when track-tuning a 4500 DOMINATOR HP carburetor for maximum performance. The kit includes four (4) of each air bleed size from #23 to #78. All bleeds are #10-32 UNF thread. Air bleeds are contained in a plastic case that is designed to keep them separated and make them easily accessible.



Jet Assortment Kit Part # 36-181^(B)

Holley 2-bbl and 4-bbl Performance Carburetors

The Holley jet assortment kit is the professional way to track-tune your Holley carburetor for top performance. This kit consists of two (2) each of thirty-six (36) different jet sizes, ranging from #64 to #99. The jets are contained in a plastic case that is designed to keep them separated and make them easily accessible. Jet sizes selected will give the broadest range of adjustment and tuning for most performance carburetor applications. 1/4 - 32 thread.



Emulsion Bleed Kit Part # 36-322^(B)

This kit contains a selection of emulsion bleeds that can be used for tuning the 0-80507-1 & 0-80507-2 carburetor. 6 - 32 thread. It consist of the following:

OPTIONAL PARTS & KITS

DESCRIPTION	Qty
Emulsion Jet Blank	10
Emulsion Jet 0.020	10
Emulsion Jet 0.031	10
Emulsion Jet 0.040	10
Emulsion Jet 0.046	10
Emulsion Jet 0.052	10



Alcohol Jet Kit Part # 36-201^(B)

This Holley jet assortment kit consists of 4 EA. of 24 standard length jets that range in size from .132" to .200". These jets will not fit the standard Holley metering block; they are designed to fit only the 750 and 950 CFM HP and 0-80586 HP DOMINATOR alcohol carburetors featured elsewhere in this catalog. The assortment is packaged in a durable plastic carrying case. 5/16 - 32 thread.



Jet Holder Kit Part # 20-111

The handy way to keep your jets organized. The Holley Jet Holder contains twenty (20) individual compartments that can hold two (2) jets. Therefore twenty (20) different jet sizes can be conveniently held for immediate access. The rotating top prevents spillage and the clear plastic allows for easy viewing.



(B) Not legal for sale or use in California on any pollution controlled motor vehicles.

Metering Plates

Many Holley performance carburetors use a secondary metering plate, with drilled restrictions, rather than a secondary metering block, with removable jets. When recalibrating the secondary side on such a carburetor a change of the secondary metering plate is required.

The picture, below, shows a typical secondary metering plate. Noted are the secondary idle feeds (Hole "B") and the secondary main metering restrictions (Hole "A"). These, in turn, relate to the chart with which the metering plate specifications can be determined.

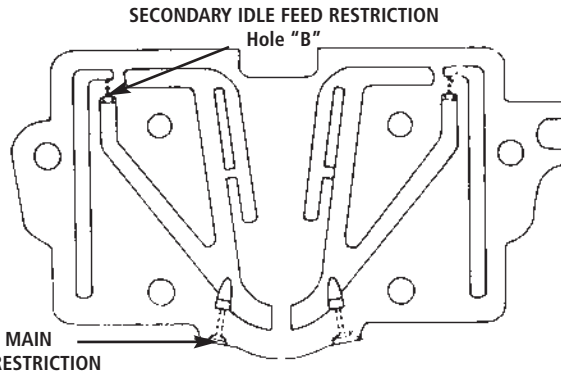

Holley Secondary Metering Plates

MAIN HOLE "A"	IDLE HOLE "B"	HOLLEY P/N	PART STAMPED
.052	.029	34R9716-34	34
.055	.026	34R9716-3	3
.059	.029	34R9716-32	32
.067	.026	134-8	8
.067	.031	134-9	9
.070	.026	34R9716-6	6
.073	.029	134-39	39
.073	.031	134-37	37
.076	.028	34R9716-22	22
.076	.031	34R9716-12	12
.076	.035	34R5113-3	3
.081	.040	134-21	21
.089	.040	34R9716-27	27
.096	.040	34R9716-45	45

Metering-Plate-to-Main-Jet Correlation Chart

The chart below can be used as a guide when correlating main metering jet part numbers to secondary metering plates. This is necessary when converting the secondary metering plate to a metering block, with replaceable jets, as with the conversion kits listed above.

SECONDARY METERING PLATE PART #	EQUIVALENT MAIN JET PART #
134-8	122-64
134-9	122-64
134-21	122-75
134-37	122-69
134-39	122-69
34R5113-3	122-65
34R9716-3	122-56
34R9716-6	122-69
34R9716-12	122-73
34R9716-22	122-65
34R9716-27	122-79
34R9716-32	122-59
34R9716-34	122-53
34R9716-54	122-75
34R9716-59	122-56

Metering Block Service Parts



Main Jet Extensions

Part # 122-5000 (1/4 - 32 thread)

An improved jet extension design that actually screws into the metering block. The main metering jet then threads into the end of the extension. The installation effectively moves the fuel entry point for the main jet out into the fuel bowl. In this location it cannot be uncovered by fuel, causing a lean condition, during periods of hard acceleration or braking. 2/Pkg.

WARNING: Requires the use of special notched" floats to achieve proper clearance and enable the float to operate normally.



Idle Mixture Screw

Part # 26-101

Accessible, large head style



Idle Mixture Screw Gasket

Part # 26-110-10

Replacement cork gasket (Pkg. 10)



Metering Block Plugs

Part # 26-111-10

Main well plugs (Pkg. 10)
.258" diameter



Metering Blocks

Model 4160 to 4150 Conversion Kits

NOTE: Illustrated is a typical kit. Fuel bowls are not included and the metering block has no provision for a power valve. Both a "shiny finish" and a "standard finish" are available as denoted right.

Part #	FINISH	APPLICATION
34-6	standard	0-1850 or most any model 4160 with side hung float bowls
34-6S	shiny	0-1850S & 0-80457S
34-13	standard	0-3310 or most any model 4160 with center hung float bowls
34-13S	shiny	0-3310S & 0-80508S

HOW TO CHOOSE A CARB
STREET CARBURETORS
SUPERCHARGER CARBURETORS
RACE CARBURETORS
MARINE CARBURETORS
CARB SERVICE PARTS & ACCESSORIES
FUEL INJECTION
THROTTLE BODIES
FUEL PUMPS
INTAKE MANIFOLDS
CYLINDER HEADS
SYSTEMAX
ENGINE DRESS-UP
MERCHANDISING
TECHNICAL INFORMATION
INDEX

Needle & Seat Assemblies

Holley offers a number of needle and seat assemblies for its carburetors. The configuration of the needle and seat assembly and its seat size depend on carburetor application, CFM size and type of fuel bowl used. Operation is simple. Needle movement is controlled by a metal tang on the float arm. Upward movement of the float causes the needle to close the seat; downward float movement causes the needle to open the seat. Seat size determines how much fuel can flow at a certain pressure. A bigger seat size will flow more fuel; a smaller seat size will flow less fuel at a given pressure.

"Viton®" Inlet Needles

Most Holley performance carburetors come equipped with a Viton®-tipped needle. The Viton® needle design is resistant to dirt and conforms nicely to the shape of the seat for superior sealing. **For this reason it is not recommended to use a steel or titanium needle, except for racing.** Thread diameter 3/8 - 32

Seat Size	Type*	Part#
.097"	Adjustable (single pack)	6-506
.097"	Adjustable (single pack)	6-508
.110"	Adjustable (single pack)	6-504
.120"	Adjustable (2 pack)	6-518-2
.0785"	Non-Adjustable (single pack)	6-511
.110"	Non-Adjustable (single pack)	6-510
.097"	Off-Road (single pack)	6-513

Viton® is a registered trademark of Dupont Performance Elastomers

"Titanium" Inlet Needle

Part # 6-521

With a .150" seat, this needle and seat assembly is about as big as you can get. What's really trick, though, is that the needle is made of titanium! This needle design is very responsive to changes in flow rates and has excellent sealing capabilities.



6-506



6-511



6-513



6-502



6-521

"Steel" Inlet Needles

"Steel-tipped" inlet needles are necessary when using exotic racing fuels or alcohol or when using benzine or acetone additives. A .097" seat size should be used for small four barrel carburetors; a .110" seat size should be used for carburetors up to 735 CFM; larger seat sizes should be used with carburetors 750 CFM and larger. The following steel inlet needle and seat assemblies are available from Holley.

Seat Size	Type*	Part#
.097"	Adjustable (2 pack)	6-501-2
.110"	Adjustable (2 pack)	6-500-2
.120"	Adjustable (2 pack)	6-502-2
.130"	Adjustable (2 pack)	6-515-2
.150"	Adjustable (2 pack)	6-519-2

* "Type" refers to the needle and seat design. The "adjustable" needle and seat design allows external float adjustment, without removing the fuel bowl. The "non-adjustable" needle and seat design does not provide for external float adjustment. The fuel bowl must be removed for this procedure. All Holley model 2010, 2300, 4010, 4011, 4150, 4160, 4165, 4175 and 4500 DOMINATOR carburetors will take either one version or the other. Center hung fuel bowls use only the "adjustable" style needle and seat, as do all model 2010, 4010, 4011 and 4500 DOMINATOR carburetors. Side hung fuel bowls have come in a variety of styles over the years and have used both the "adjustable" and "non-adjustable" styles needle and seats.

Adjustable Needle and Seat Hardware Kit Part # 34-7

This Kit contains:

- 1 EA Adjusting nut with gasket
- 1 EA Locking screw with gasket
- 1 EA O-ring



The Truth About The Power Valve

POWER VALVE IDENTIFICATION

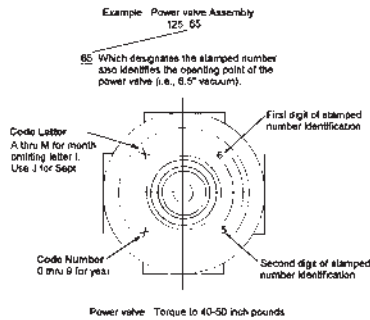

Cut-away of power valve blow-out protection.

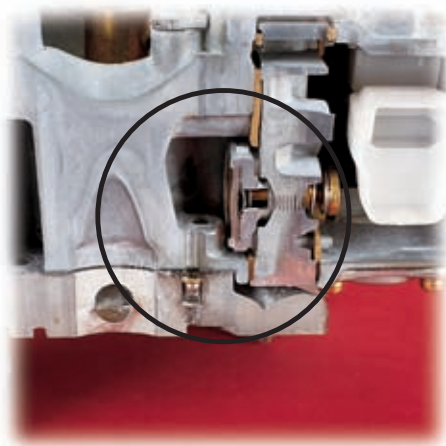

TECH TIP

Power Valves and Carburetors for Superchargers

Holley carburetors that are intended for use with superchargers, have a unique capability that allows their power valves to reference the intake manifold vacuum below the supercharger. This allows the power valve to operate as it should, based off intake manifold vacuum. A power valve provides further enrichment to the main metering system under load (low vacuum) conditions. Without this external referencing, the power valve would be "reading" the supercharger boost pressure, which has no bearing on the engine load.

Power Enrichment System

The power enrichment system supplies additional fuel to the main system during heavy load or full power situations. Holley carburetors utilize a vacuum operated power enrichment system and a selection of power valves is available to "time" this system's operation to your specific needs. Each Holley power valve is stamped with a number to indicate the vacuum opening point. For example, the number "65" indicates that the power valve will open when the engine vacuum drops to 6.5" or below. An accurate vacuum gauge, such as Holley P/N 26-501, should be used when determining the correct power valve to use. A competition or race engine which has a long duration high overlap camshaft will have low manifold vacuum at idle speeds. If the vehicle has a manual transmission, take the vacuum reading with the engine thoroughly warmed up and at idle. If the vehicle is equipped with an automatic transmission, take the vacuum reading with the engine thoroughly warmed up and idling in gear. In either case, the power valve selected should be 1/2 the intake manifold vacuum reading taken. EXAMPLE: 13" Hg vacuum reading divided by 2 = 6.5 power valve. If your reading divided by 2 lands on an even number you should select the next lowest power valve. EXAMPLE: 8" Hg vacuum reading divided by 2 = 4 power valve. Since there is no #4 power valve you should a 3.5.

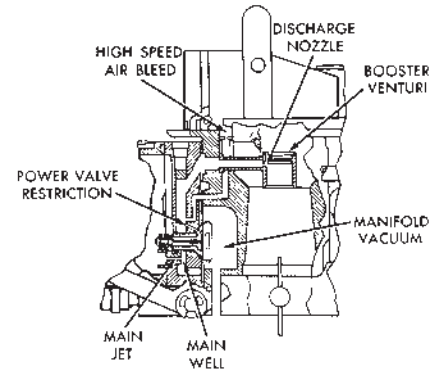

Power Enrichment System.

Most of the popular Holley "Street Legal" and "Street Performance" carburetors incorporate a power valve blow-out protection system. A special check valve is located in the throttle body expressly for this purpose. This check valve is designed to be normally open but will quickly seat to close off the internal vacuum passage when a backfire occurs. Once closed, the check valve interrupts the pressure wave caused by the backfire, thus protecting the power valve.

If you have a carburetor older than 1992 (or you have experienced an extreme backfire) and expect a blown power valve, use this simple test. TEST: At idle turn your idle mixture screws (found on the side of the metering block) all the way in. If your engine dies the power valve is not blown.

THE TRUTH ABOUT POWER VALVES USED WITH HOLLEY CARBURETORS

There still seems to be a lot of misconception about Holley carburetors blowing power valves. Nothing could be further from the truth. Holley performance carburetors built since 1992 have utilized a power valve check system that effectively eliminated this infrequent problem. Consisting of a spring, brass seat and check ball, the check ball system is 100% effective protecting the power valve diaphragm from damage due to engine backfire.

The power valve check ball is designed to be normally open but quickly seals to close off the internal vacuum passage when a backfire occurs. Once closed, the check valve interrupts the pressure wave generated by the backfire, thus protecting the power valve diaphragm. There is no way that the power valve's diaphragm can rupture due to an engine backfire!

Power Valves

Single-Stage (includes gasket)

PART #	OPENING VACUUM
Standard Flow	
125-10	1.0" Hg
125-25	2.5" Hg
125-35	3.5" Hg
125-45	4.5" Hg
125-50	5.0" Hg
125-55	5.5" Hg
125-65	6.5" Hg
125-75	7.5" Hg
125-85	8.5" Hg
125-95	9.5" Hg
125-105	10.5" Hg
High Flow	
125-125	2.5" Hg
125-135	3.5" Hg
125-145	4.5" Hg
125-155	5.5" Hg
125-165	6.5" Hg
125-185	8.5" Hg
125-1005	10.5" Hg



125-65

Two-Stage* (includes gasket)

PART #	1ST STAGE OPENING	2ND STAGE OPENING
Model 4160		
125-206	12.5" Hg	5.5" Hg
125-207	10.5" Hg	5.0" Hg
125-208	10.5" Hg	5.5" Hg
125-213	11.5" Hg	5.0" Hg
Model 4175		
125-209	11.0" Hg	6.0" Hg
125-210	9.0" Hg	2.5" Hg
125-211	10.5" Hg	5.5" Hg
125-212	12.0" Hg	6.5" Hg
125-215	10.0" Hg	6.0" Hg
125-216	8.0" Hg	1.5" Hg

* Two-stage power valves ARE NOT RECOMMENDED for performance applications.

Power Valve Check Ball Kit

Part # 125-500

Power valve "blowout" protection can now be added to pre '92 model 2300, 4150 and 4160 carburetors. Consisting of a spring, brass seat and check ball, this kit will effectively protect the power valve and is easy to install. Included is the proper drill bit size, with stop, to facilitate installation. Detailed instructions are included.



125-500

Power Valve Plug and Gasket

Part # 26-36

Racers sometimes will prefer to run without a power valve. In these cases a power valve plug must be used to block the power valve circuit. Furthermore, jet sizes must be increased to compensate for loss of the fuel enrichment provided by the power valve. An increase of 6 to 8 jet sizes will, in most cases, be enough compensation. It's advisable, however, to "read" the spark plugs and verify proper jetting. Power Valve Thread: 1/2-28



26-36

Tools

Heli-Coil Inserts Part # 26-3

Use to repair stripped fuel bowl screw threads in a carburetor main body

Installation Tool Kit with Inserts & Tap Part # 26-2

NOTE: need 15/64" drill bit

Main Jet Removal Tool . . . Part # 26-68

Used for jet removal



26-2



26-68

Main Jet Tap Part # 26-1

Used for "cleaning up" main jet threads in the metering block

Rich/Lean Indicator with Oxygen Sensor Part # 534-51

For carbureted, non-oxygen-sensor-equipped vehicles. Mounts on the dash and allows the monitoring of the air/fuel ratio of your engine while you drive. Enables more exact tuning.

Rich/Lean Indicator with out Oxygen Sensor Part # 534-50

For fuel injected vehicles or those that already are equipped with an oxygen sensor. Enables more exact tuning.



26-1



534-51

HOW TO CHOOSE A CARB
STREET CARBURETORS
SUPERCHARGER CARBURETORS
RACE CARBURETORS
MARINE CARBURETORS
CARB SERVICE PARTS & ACCESSORIES
FUEL INJECTION
THROTTLE BODIES
FUEL PUMPS
INTAKE MANIFOLDS
CYLINDER HEADS
SYSTEMAX
ENGINE DRESS-UP
MERCHANDISING
TECHNICAL INFORMATION
INDEX

Vacuum Secondary Diaphragms

Carburetor number	Diaphragm
R1848-1	135-2
R1849	135-4
R1850(ALL)	135-4
R2929	135-3
R2953-1	135-3
R2973	135-3
R3116	135-3
R3220	135-2
R3259-1	135-3
R3300	135-3
R3301	135-3
R3310(ALL)	135-4
R3410	135-3
R3411	135-3
R3418-1	135-3
R3659	135-6
R3977	135-3
R4118	135-3
R4168	135-3
R4174	135-3
R4201	135-3
R4202	135-3
R4235	135-3
R4236	135-3
R4279	135-3
R4280	135-3
R4365-1	135-6
R4382-1	135-6
R4383-1	135-6
R4393-2	135-6
R4394-2	135-6
R4452-1	135-4
R4548	135-4
R4671	135-6
R4672	135-6
R4789	135-6
R4790	135-6
R6127	135-3
R6128	135-3

Carburetor number	Diaphragm
R6129	135-3
R6291-1	135-4
R6299-1	135-2
R6520	135-4
R6619	135-4
R6909	135-4
R6919	135-4
R6979	135-4
R6989	135-4
R7002	135-4
R7004	135-4
R7005	135-4
R7006	135-4
R7009	135-4
R7010	135-4
R7053-1	135-4
R7154	135-4
R7351	135-4
R7397	135-4
R7855	135-4
R7985	135-4
R7986	135-4
R7987	135-4
R8004	135-4
R8005	135-4
R8006	135-4
R8007	135-2
R8059	135-4
R8060	135-4
R8181	135-4
R8207	135-4
R8276	135-4
R8302	135-4
R8546	135-4

Carburetor number	Diaphragm
R8679	135-4
R8700	135-4
R8879	135-4
R9002	135-4
R9040	135-4
R9188	135-4
R9219	135-4
R9210	135-4
R9626	135-4
R9834	135-4
R9895	135-4
R9923	135-4
R9948	135-4
R9976	135-4
R80073	135-4
R80098	135-4
R80099	135-4
R80111	135-4
R80112	135-4
R80128	135-4
R80133	135-4
R80134	135-4
R80135	135-4
R80136	135-4
R80137	135-4
R80139	135-4
R80140	135-4
R80145	135-4
R80155	135-4
R80163	135-4
R80164	135-4
R80165	135-4
R80166	135-4
R80169	135-4
R80431	135-4

Carburetor number	Diaphragm
R80432	135-4
R80436	135-4
R80450	135-4
R80451	135-4
R80452	135-4
R80453	135-4
R80454	135-4
R80457	135-4
R80460	135-4
R80476	135-4
R80491	135-4
R80497	135-3
R80508	135-4
R80512	135-3
R80519	135-3
R80529	135-3
R80670	135-4
R80681	135-4
R80770	135-3
R80870	135-3
R81850	135-4
R82750	135-3
R83310	135-4
R83311	135-4
R83312	135-4
R84010	135-4
R84011	135-4
R84014	135-3
R84015	135-3
R84020	135-4
R84021	135-3
R84035	135-4
R84047	135-4
R89834	135-4
R90570	135-4
R90670	135-4
R90770	135-4
R83670	135-4
R83770	135-3
R85670	135-4
R85770	135-3
R93670	135-4
R93770	135-4

Vacuum Secondary Operation

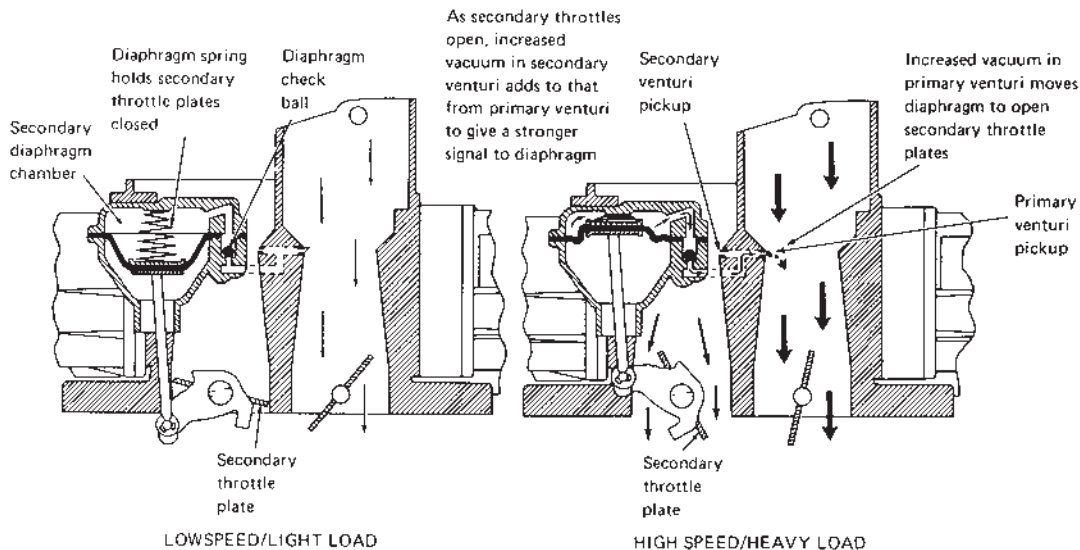

Vacuum secondaries are activated by venturii velocity through the primary venturii and further aided by secondary venturii velocity. Engine/manifold vacuum is not related and has no effect on the operation of the carburetors secondary system.

Secondary Diaphragm Spring Kit Part # 20-13^(B)

Color	Relative Load	SECONDARY THROTTLE OPERATING RANGES			
		350 CID Eng. Opening RPM		402 CID Eng. Opening RPM	
		Initial	Full	Initial	Full
White	Lightest	—	—	—	—
Yellow*	Lighter	1620	5680	1410	4960
Yellow	Light	1635	5750	1420	5020
Purple	Med. Light	1915	6950	1680	6050
Plain	Medium	2240	8160	1960	7130
Brown	Med. Heavy	2710	8750	2380	7650
Black	Heavy	2720	Not Fully Open	2390	Not Fully Open

* Short Spring



Clamp Kit -

Choke Control Cable . . . Part # 45-456

For manual chokes. Required when changing over from plastic to metal diaphragm cover.



45-456

Cover -

Diaphragm Housing. . . Part # 20-28

2 x 4 bbl. applications. Allows vacuum hookup between carburetors for more even and balanced secondary operation. (2 covers included)



20-28

Cover -

Diaphragm Housing . . . Part # 20-77

1 x 4 applications. Replacement plastic cover for 4 bbl. carburetor.



20-77

Cover Diaphragm Housing

Part # 20-85 Standard; Part # 20-85S Shiny

1 x 4 applications. Replacement metal cover for 4 bbl. carburetor.



20-85

Secondary Diaphragm

Housing and Cover. . . Part # 34-503

Replacement chrome housing and cover for vacuum secondary carburetors.



34-503

Cover Diaphragm

Housing Adjustable . . . Part # 20-99^(B)

A must for bracket racers! This unique kit is designed to limit the opening of vacuum-actuated, secondary throttle plates. This is accomplished easily and accurately by turning a specially calibrated knob. Now you can have the ability to speed up or slow down your race car and thus compensate for changing track and atmospheric conditions. Keep running on your "dial-in" with this kit! Cannot be used with stock air cleaners.



20-99

Gasket (cork) Part # 108-67-20

Seals vacuum passage between vacuum secondary housing and main body. Also is used with automatic choke housings.



108-67-20

Cover Diaphragm Housing

(Quick Change). Part # 20-59^(B)

1x 4 bbl. – without balance tube. Expedites changing of vacuum spring.



20-59

Cover Diaphragm Housing

(Quick Change). Part # 20-73^(B)

2 x 4 bbl. – with balance tube. Expedites changing of vacuum spring. (2 covers included)



20-73

Venturii Booster Kits For DOMINATOR Carburetors



Old style Dominator. Short-style booster. Includes 4 boosters and

4 retaining pins. Part # 34-32



34-32

Old style Dominator. Annular-style booster. Includes 4 boosters

and retaining pins. Part # 34-9



34-9

Annular/skirt-style booster for HP-style DOMINATOR 750 CFM. Includes 4 boosters

and 4 retaining pins. Part # 34-36



34-34

Annular-style booster for HP-style DOMINATOR. Includes 4 boosters and

4 retaining pins. Part # 34-34

Booster Pins Part # 20-110-10

HP Dominator booster pins. 10/pkg.



20-110-10

(B) Not legal for sale or use in California on any pollution controlled motor vehicles.

HOW TO CHOOSE A CARB
STREET CARBURETORS
SUPERCHARGER CARBURETORS
RACE CARBURETORS
MARINE CARBURETORS
CARB SERVICE PARTS & ACCESSORIES
FUEL INJECTION
THROTTLE BODIES
FUEL PUMPS
INTAKE MANIFOLDS
CYLINDER HEADS
SYSTEMAX
ENGINE DRESS-UP
MERCHANDISING
TECHNICAL INFORMATION
INDEX



**STEALTH
RAM**

"Just got back from our 3-1/2 week trip to our final three ACES Regional events (Kansas City, Denver, and Seattle), and put over 7000 miles on the wagon. The Holley Stealth Fuel Injection unit performed flawlessly!"

— **Chuck Hanson**
Horsepower TV Host



FUEL INJECTION



FUEL INJECTION 98 - 118

Commander 950® Pro Overview	98-99
Commander 950® Engine Systems	100
Stealth Ram™ Multi-Point Fuel Injection Systems	101
Commander 950® MPFI Specific	102-103
Commander 950® Systems & Hardware	104
Commander 950® Hardware & MPFI Power Packs	105
MPFI Power Packs.	106
Stealth Ram™ MPFI Power Packs	107
Commander 950® Service Parts	108-109
Commander 950® 4-bbl Throttle Body Fuel Injection.	110-112
Marine Commander 950® 4-bbl Throttle Body Fuel Injection . .	112
670 CFM Pro-Jection®	113
Marine Pro-Jection® 2-bbl Throttle Body Fuel Injection.	113
Throttle Body Service Parts	114-117
Fuel Rails & Injector Kits	118

Commander 950® PRO Overview

The Holley Commander 950 ECU provides the customer with a high level of tuning flexibility to control engines from mild to wild. From stock, naturally aspirated engines, to high horsepower supercharged engines, the Commander 950 gives you the power to precisely tune all functions of an engine.

The Commander 950 allows for real-time tuning of all parameters. The Windows-based software is simple to use for the beginner and has all the features necessary for experienced tuners.

All Commander 950 Systems come standard with the Pro Software. Pro Software comes with many features that help allow the precise tuning of any street or race engine.



Features and Engine/Hardware Compatibility











- Compatible with 4, 6 and 8 cylinder even fire engines
- Operates as speed density or alpha-N
- Can be programmed to run alpha-N at idle only
- 16 x 16 fuel and timing maps
- Uses 1, 2 or 3 Bar MAP sensors
- Programmable load and RPM scales
- Maximum RPM of 12,750
- Controls GM and Chrysler stepper IAC valves
- Compatible with GM knock sensor
- Controls 8 high or 4 low impedance injectors
 - will control 8 low impedance injectors with P/N 534-122
- Controls TBI fuel injection with 1 to 1 or progressive linkage
- Operates in closed and open loop
- Controls narrow band and any wide band O₂ sensor with 0-5 volt output
 - 8 x 8 target air/fuel ratio chart
 - 8 x 8 + and - closed loop compensation limits
- Full tuning for:
 - startup and warm-up fuel enrichment
 - acceleration fuel enrichment based on MAP and TPS sensors
 - timing vs coolant temperature
 - deceleration fuel cut-off
 - fueling strategy
- Timing control feature can be achieved through the use of:
 - small cap computer controlled GM HEI (stock GM or Holley P/N 890-160)
 - large cap computer controlled GM HEI
 - Ford TFI distributor
 - magnetic crank trigger
 - hall effect crank trigger
- Integrated rev limiter
- PC and internal datalogger (logs to ECU) standard. Fully programmable operation
- Programmable inputs and outputs (timing retards, RPM activated switches, etc.)
- ECU size is 5.5" x 4.75" x 2.0"



Commander 950® Engine Management System Kits

These Holley kits are intended to replace and upgrade existing fuel injection electronics or to provide a state-of-the-art electronic control module, if none is currently available. The Holley Commander 950 is the most powerful and capable ECU available on the market today. Capable of driving up to 8 high impedance and 4 low impedance injectors, the Commander 950 can provide all the power and sophistication required for any street or strip fuel injected motor. These Holley engine management system kits contain the Commander 950 ECU, wiring harness and sensors, where applicable, that you'll need to make a customized fuel injection installation.

NOTE: These systems are designed only for fuel and spark management. Items such as cruise control, transmission control, AC, ABS, etc are not controlled by the Commander 950.

Application	Part#
Holley 1D/2D Pro-Jection systems (replaces and upgrades existing Pro-Jection electronics)	950-113 (B) 
Holley 4D and 4Di Pro-Jection systems (replaces and upgrades existing Pro-Jection electronics)	950-100 (B) 
Holley MPI Pro-Jection II systems (replaces and upgrades existing Pro-Jection electronics)	950-103 (B) 
1985-92 GM TPI (tuned port injection) engine applications	950-101 (B) 
1992-97 GM LT1/LT4 engine applications (requires a custom crank trigger installation)	950-105 (B) 
1986-95 Ford 5.0L EFI V8 engine applications	950-106 (B) 
Universal V8 multi-point fuel injection	950-109 (B) 
Universal V6 multi-point fuel injection	950-110 (B) 
Universal 4cyl. & import multi-point fuel injection	950-104 (B) 
Universal engine controller kit for customized applications (includes 20' long, non-terminated harness for cut-to-length flexibility)	950-115 (B) 

SERVICE PARTS

Cable, communication, laptop computer; Provides ECU to laptop computer connection **Part # 534-140**

Distributor wiring harness adapter, Chevrolet HEI; Small cap distributor **Part # 534-138**

Distributor wiring harness adapter, Ford TFI **Part # 534-139**

ECU, Commander 950 (except LS1 kit) . . **Part # 534-120**
Marine **Part # 534-181**

Relay kit, cooling fan; Includes relay & wiring for cooling fan **Part # 534-134**

Sensor, knock, wiring connector kit; Does not include module or sensor **Part # 534-136**

Software, Commander 950
Mapping & set up. **Part # 534-144**

Software, Commander 950 PRO; Mapping & set up & ECU firmware upgrade **Part # 534-191**

Wiring harness, injectors
Universal 4cyl. kit P/N 950-104 **Part # 534-153**
Ford 5.0L V8 kit, P/N 950-106 **Part # 534-131**
Universal V6 kit, P/N 950-110 **Part # 534-152**
Universal S/B V8 (over the fuel rail). **Part # 534-129**
Universal B/B V8 (over the plenum). **Part # 534-130**
Universal 4 cyl. **Part # 534-182**

Wiring harness, magnetic pick up; Provides wiring for magnetic pick up installation **Part # 534-135**

Wiring harness, main

Used with kit, P/N 950-100 **Part # 534-146**
Used with kit, P/N 950-101 **Part # 534-128**
Used with kit, P/N 950-102 **Part # 534-147**
Used with kit, P/N 950-103 **Part # 534-142**
Used with kit, P/N 950-104 **Part # 534-182**
Used with kit, P/N 950-105 **Part # 534-148**
Used with kit, P/N 950-106 **Part # 534-149**
Used with kit, P/N 950-109 **Part # 534-142**
Used with kit, P/N 950-114 **Part # 534-157**
Used with kit, P/N 950-115 **Part # 534-143**

Auxiliary Injector Driver Kit **Part # 534-195**

Designed to work with ECUs (like the Holley Commander 950) that have four (4) "peak to hold drivers". What this module does is expand the ECU's capability to control eight (8) "peak & hold drivers", allowing the use of eight (8) low impedance injectors. With this additional capability, running either a 2x4 throttle body setup (requires additional harness 534-196) or plug and play in a multi point system running 8 low impedance injectors is possible.



































2X4 TBI wiring harness. Part # 534-196



STEALTH RAM™ Multi-Point Fuel Injection Systems

Want to get "Oooos" and "Ahhhs" every time you open the hood? Want to feel real power every time you step on the loud pedal? Then you'd better get Holley's new STEALTH RAM™ MPFI system on your street machine. Tunnel ram design helps to build power. The plenum and runner designs promote excellent mid-range torque along with outstanding high RPM power. The available polished finish makes you look good. Commander 950™ software and electronics helps you get down the road in no time.

STEALTH RAM™ MPFI systems are complete and include a 2x58mm billet throttle body. The following are available:

Part #	Part# with Wide Band O ₂	Vortec Applications	Vortec w/ WBO ₂ Applications	Description	HP Range*
91503201 ^(B) 	91503211 ^(B) 	91703201 ^(B) 	91703211 ^(B) 	Satin w/ 24 lb/hr injectors	300 - 385
91504201 ^(B) 	91504211 ^(B) 	91704201 ^(B) 	91704211 ^(B) 	Satin w/ 30 lb/hr injectors	385 - 480
91505201 ^(B) 	91505211 ^(B) 	91705201 ^(B) 	91705211 ^(B) 	Satin w/ 36 lb/hr injectors	480 - 575
91506201 ^(B) 	91506211 ^(B) 	91706201 ^(B) 	91706211 ^(B) 	Satin w/ 42 lb/hr injectors	575 - 670
91403201 ^(B) 	91403211 ^(B) 	91603201 ^(B) 	91603211 ^(B) 	Polished w/ 24 lb/hr injectors	300 - 385
91404201 ^(B) 	91404211 ^(B) 	91604201 ^(B) 	91604211 ^(B) 	Polished w/ 30 lb/hr injectors	385 - 480
91405201 ^(B) 	91405211 ^(B) 	91605201 ^(B) 	91605211 ^(B) 	Polished w/ 36 lb/hr injectors	480 - 575
91406201 ^(B) 	91406211 ^(B) 	91606201 ^(B) 	91606211 ^(B) 	Polished w/ 42 lb/hr injectors	575 - 670
	91500011 ^(B) 			Satin w/ no injectors or fuel pump	_____

(*) A brake specific fuel consumption (BSFC) of .45 and 90% duty cycle is used for the maximum horsepower recommendation.

System features:

- Fits early and late(**) model 23° Chevrolet cylinder heads and Vortec heads
 - Computer controlled timing available using 1984-1996 GM external coil distributor (billet Holley version available under P/N 890-160).
 - Base maps for various combinations to get you started
 - Designed to use GM TPI throttle and transmission cables and brackets
- (**) Requires angled bolt spacers, P/N 90748

Systems include:

- Upper and lower intake manifolds
- 58mm billet throttle body
- Bright clear anodized aluminum fuel rails
- Fuel injectors
- Fuel pressure regulator
- 255 LPH fuel pump and fuel filters
- Commander 950™ ECU
- All wiring harnesses
- Software and communications cable
- TPS, MAP, coolant, air temperature and oxygen sensors
- No EGR provision
- No 9th injector port
- Detailed installation and tuning manuals
- WBO₂ kits include NTK sensor

Specifications:

- Height is 10-1/4"
- Shipping weight is approximately 45 lbs.



Commander 950® Multi-Point Fuel Injection Systems

Commander 950 Multi-Point Fuel Injection Systems are intended for carbureted, non-emission, non-computerized Chevrolet small block and big block V8 engines. Ford small block V8 engines are not forgotten, as some very special systems are also available for them.

These are complete systems that are engineered to provide all the components and hardware needed for your custom installation. The intake manifold, billet throttle body, billet fuel rails, injectors and related miscellaneous parts are partially pre-assembled and tested prior to packaging. Holley takes this extra step in quality assurance to verify the performance, quality and integrity of the system.



With the addition of Commander 950 electronics, Holley multi-point fuel injection systems offer more in the way of features, more in the way of performance, more in the way of system capability, more in the way of outright good looks and more in the way of value! The product features, listed below, should explain this well enough.

Whether your engine is stock, crate or custom-built, a Holley Commander 950 multi-point fuel injection system can help maximize its performance characteristics and make your cruising times a lot more enjoyable.

Features

- These stand-alone systems are partially pre-assembled at the factory and contain all components necessary for installation, including a detailed installation guide.
- Commander 950 ECU control functions are accessible with supplied Holley software and fully programmable with a personal laptop computer with WIN 3.1, '95, '98, NT.
- Throttle bodies available in the following styles:
 - 1000 CFM billet w/ 4-bbl square bore and 5-1/8" air horn
 - 2000 CFM billet w/ DOMINATOR flange
- Fits the following Chevrolet engines:
 - Small block w/ 23° standard port heads (early & late)
 - Small block w/ Vortec cylinder heads
 - Big block oval port heads
 - Big block rectangular port heads - including tall decks
- Sensors include: throttle position, MAP, engine and air temperature, exhaust oxygen and idle air control motor
- Wiring harness is designed for "plug-in" installation.
- WBO₂ kits include NTK sensor

- Adjustable timing is available with any of the following distributors:
 - 1980-1/2 - 1990 GM 7-pin (coil-in-cap)
 - 1984 - 96 GM (external coil)
 - 1984 - later Ford 7-wire TFI
 - Aftermarket computer controlled distributors (Holley P/N 890-160 - SB Chevy)











The Commander 950™ ECU's adjustable timing feature will also work with any CD ignition that does not have timing control if used with one of the above-listed distributors.











- Base fuel maps available off the Holley Web site.
- Systems available with 3-wire narrowband or wideband O₂ sensors









Benefits













- Vastly improved fuel distribution and cylinder filling
- Excellent throttle response, driveability and fuel economy
- Impressive torque and horsepower gains over standard carburetion
- Superior idle, warm up and part-throttle driving characteristics













Commander 950® Multi-Point Fuel Injection Systems

HP RANGE	CFM	Throttle Body FLANGE	INJECTOR SIZE	SYSTEM PART NUMBER	
				In-Line Fuel Pump	w/ Wide Band O ₂
Naturally Aspirated Applications:		Chevrolet Small Block V8; early/late cylinder heads			
225 - 300*	1000	square flange	19 lbs./hr.	91002101 (B) 	
300 - 385*	1000	square flange	24 lbs./hr.	91003101 (B) 	91003111 (B) 
385 - 480*	1000	square flange	30 lbs./hr.	91004101 (B) 	91004111 (B) 
480 - 575*	1000	square flange	36 lbs./hr.	91005201 (B) 	91005211 (B) 
575 - 670*	1000	square flange	42 lbs./hr.	91006201 (B) 	91006211 (B) 
670 - 800*	1000	square flange	50 lbs./hr.	91007201 (B) 	91007211 (B) 

Naturally Aspirated Applications:		Chevrolet Small Block V8; Vortec cylinder heads			
225 - 300*	1000	square flange	19 lbs./hr.	91102101 (B) 	
300 - 385*	1000	square flange	24 lbs./hr.	91103101 (B) 	91103111 (B) 
385 - 480*	1000	square flange	30 lbs./hr.	91104101 (B) 	91104111 (B) 
480 - 575*	1000	square flange	36 lbs./hr.	91105201 (B) 	91105211 (B) 
575 - 670*	1000	square flange	42 lbs./hr.	91106201 (B) 	91106211 (B) 
670 - 800*	1000	square flange	50 lbs./hr.	91107201 (B) 	91107211 (B) 

Naturally Aspirated Applications:		Chevrolet Big Block V8; Std. Deck; Oval Port cylinder heads			
385 - 480*	1000	square flange	30 lbs./hr.	92004101 (B) 	92004111 (B) 
480 - 575*	1000	square flange	36 lbs./hr.	92005201 (B) 	92005211 (B) 
575 - 670*	1000	square flange	42 lbs./hr.	92006201 (B) 	92006211 (B) 
670 - 800*	1000	square flange	50 lbs./hr.	92007201 (B) 	92007211 (B) 

Naturally Aspirated Applications:		Chevrolet Big Block V8; Std. Deck; Rectangular Port Heads			
385 - 480*	1000	square flange	30 lbs./hr.	92104101 (B) 	92104111 (B) 
480 - 575*	1000	square flange	36 lbs./hr.	92105201 (B) 	92105211 (B) 
575 - 670*	1000	square flange	42 lbs./hr.	92106201 (B) 	92106211 (B) 
670 - 800*	1000	square flange	50 lbs./hr.	92107201 (B) 	92107211 (B) 
575 - 670*	2000	Dominator flange	42 lbs./hr.	92306201 (B) 	92306211 (B) 
670 - 800*	2000	Dominator flange	50 lbs./hr.	92307201 (B) 	92307211 (B) 

Naturally Aspirated Applications:		Chevrolet Big Block V8; Tall. Deck; Rectangular Port Heads			
385 - 480*	1000	square flange	30 lbs./hr.	92204101 (B) 	92204111 (B) 
480 - 575*	1000	square flange	36 lbs./hr.	92205201 (B) 	92205211 (B) 
575 - 670*	1000	square flange	42 lbs./hr.	92206201 (B) 	92206211 (B) 
670 - 800*	1000	square flange	50 lbs./hr.	92207201 (B) 	92207211 (B) 
575 - 670*	2000	Dominator flange	42 lbs./hr.	92406201 (B) 	92406211 (B) 
670 - 800*	2000	Dominator flange	50 lbs./hr.	92407201 (B) 	92407211 (B) 

(*) A brake specific fuel consumption (BSFC) of .45 and 90% duty cycle is used for the maximum horsepower recommendation.

(**) A brake specific fuel consumption (BSFC) of .6 and 90% duty cycle is used for the maximum horsepower recommendation.

NOTE: Downloadable base fuel maps are available at www.holley.com.

Commander 950® Multi-Point Fuel Injection Universal Kits

Install multi-port fuel injection on any engine!

System includes most components necessary to retrofit multi-port electronic fuel injection on nearly any vehicle. Just use your single plane manifold of choice and you have a customized EFI motor.

Part #	Kit Description
534-183 ^(B)	1000 CFM throttle body
534-184 ^(B)	2000 CFM throttle body



Kits include:

- Commander 950 ECU
- Pre-terminated wiring harness
- 1000 or 2000 CFM billet aluminum throttle body
- Billet aluminum fuel pressure regulator
- 8 injector bungs
- aluminum fuel rails
- MAP, coolant, air temperature, and oxygen sensors
- Software

- Comprehensive installation & tuning manuals

Additional requirements:

- Fuel injectors sized to application
- Fuel pump and filters sized to application
- Machining of supplied fuel rails
- Machining & welding of injector bungs & fuel rail hold-downs
- Plumbing
- New throttle cable bracketry

Commander 950® Race MPFI Systems



- Designed for BBC Bracket and Hot Street Engines
- Economically priced with all the features a racer needs
- Wide band oxygen sensor and internal datalogger make on-track tuning simple
- 42 or 50 lb/hr injectors
- Rectangular Port BBC
- Standard or Tall Deck Blocks
- 1000 (4150) or 2000 (4500) CFM Throttle Bodies
- Includes throttle body, manifold, injectors, fuel rails, wiring harness, ECU, software, NTK Wide Band sensor and controller
- Customer supplies fuel pump, fuel filters and fuel pressure regulator

Part #	Pro Commander systems w/ wide band O2
92106011	Standard Deck Big Block Chevy, 1000 CFM, 42 lb/hr w/ Wide Band Oxygen Sensor
92306011	Standard Deck Big Block Chevy, 2000 CFM, 42 lb/hr w/ Wide Band Oxygen Sensor
92107011	Standard Deck Big Block Chevy, 1000 CFM, 50 lb/hr w/ Wide Band Oxygen Sensor
92307011	Standard Deck Big Block Chevy, 2000 CFM, 50 lb/hr w/ Wide Band Oxygen Sensor
92207011	Tall Deck Big Block Chevy, 1000 CFM, 50 lb/hr w/ Wide Band Oxygen Sensor
92407011	Tall Deck Big Block Chevy, 2000 CFM, 50 lb/hr w/ Wide Band Oxygen Sensor

Commander 950® Wide Band O2 Upgrade Hardware **Part # 534-188**



KIT CONTAINS:

- NTK Oxygen Sensor
- Sensor controller
- PRO software and Commander 950 ECU Firmware Upgrade Certificate
- Comprehensive manual

The wideband oxygen sensor is the ultimate addition to any new or existing Commander 950 EFI system. It will plug directly into all Commander 950 harness and accurately measure any air/fuel ration between 10:1 and 20:1. This allows the engine tuner to read the air/fuel ratio in real time for extremely accurate tuning. The PRO software, that is included with the upgrade, features a 64 cell target air/fuel ratio matrix. This feature enables the tuner to program the ECU to operate the engine at any target air/fuel ratio for best power and economy. All engines will benefit from this upgrade and it is a virtual "must have" for forced induction engines. NTK sensors are recommended for leaded fuel & very high EGT (exhaust gas temp) applications.

NTK replacement O2 sensors

- 534-190 1st generation
- 534-194 2nd generation

Commander 950® Wide Band O2 Upgrade Kit with BOSCH® Sensor Part # 534-197



- Small weather-sealed unit for convenient mounting
- Accurately measures air & fuel ratio between 10:1 & 18:1
- Upgrade an older Commander 950 ECU to "PRO" software compatibility with included certificate
- Includes Bosch® LSU4 sensor
- Budget-minded pricing
- Replacement Bosch O2 sensor 534-798

Commander 950™ Wide Band O2 Gauge Part # 534-200

- Features a 3-digit numeric display & 40 segment bar graph
- Uses ultra-high intensity light emitting diodes for easy viewing even under direct sunlight
- Standard 2-1/16" diameter for ease of mounting in a standard gauge pod
- Designed to operate over a temperature range of -4 to + 185° F
- Built for race environments to withstand heat, dirt & vibration
- Connects directly to Wide Band O2 controllers (p/n 534-188) by simply plugging it in and running a switched power and ground to the gauge.

Multi-Point Fuel Injection Power Pack Kits

New Holley MPI Power Packs are partially assembled and come without an ECU, wiring harness and fuel pump. They are intended for the person who may want to use, or already has, different ECU components. These Power Pack kits can be used with other aftermarket speed-density-type ECUs that are designed for use on a multi-point system.

Features

- Power Packs are complete multi-point systems except for ECU, wiring harness and fuel pump
- Fits Chevrolet small block 23° standard port (early and late) Vortec cylinder heads
- Fits Chevrolet big block oval and rectangular port V8s, including tall decks
- Includes billet throttle body with progressive linkage
- Includes high fuel flow capacity fuel rails, sensors & connectors
- Realize increased torque and horsepower
- Enjoy vastly improved throttle response and idle control



HP RANGE	CFM	Throttle Body FLANGE	INJECTOR SIZE	Part Number
Naturally Aspirated Applications:				
Chevrolet Small Block V8; Early/Late Cylinder Heads				
225 - 300*	1000	square flange	19 lbs./hr.	81002001 (B)
300 - 385*	1000	square flange	24 lbs./hr.	81003001 (B)
385 - 480*	1000	square flange	30 lbs./hr.	81004001 (B)
480 - 575*	1000	square flange	36 lbs./hr.	81005001 (B)
575 - 670*	1000	square flange	42 lbs./hr.	81006001 (B)
670 - 800*	1000	square flange	50 lbs./hr.	81007001 (B)
880 - 1050*	1000	square flange	65 lbs./hr.	81009001 (B)

Continued on next page...

(*) A brake specific fuel consumption (BSFC) of .45 and 90% duty cycle is used for the maximum horsepower recommendation.

Multi-Point Fuel Injection Power Pack Kits

HP RANGE	CFM	Throttle Body FLANGE	INJECTOR SIZE	Part Number
Naturally Aspirated Applications:				
Chevrolet Small Block V8; Vortec Cylinder Heads				
225 - 300*	1000	square flange	19 lbs./hr.	81102001 (B)
300 - 385*	1000	square flange	24 lbs./hr.	81103001 (B)
385 - 480*	1000	square flange	30 lbs./hr.	81104001 (B)
480 - 575*	1000	square flange	36 lbs./hr.	81105001 (B)
575 - 670*	1000	square flange	42 lbs./hr.	81106001 (B)
670 - 800*	1000	square flange	50 lbs./hr.	81107001 (B)
880 - 1050*	1000	square flange	65 lbs./hr.	81109001 (B)

Naturally Aspirated Applications:				
Chevrolet Big Block V8; Std. Deck; Oval Port Heads				
385 - 480*	1000	square flange	30 lbs./hr.	82004001 (B)
480 - 575*	1000	square flange	36 lbs./hr.	82005001 (B)
575 - 670*	1000	square flange	42 lbs./hr.	82006001 (B)
670 - 800*	1000	square flange	50 lbs./hr.	82007001 (B)
880 - 1050*	1000	square flange	65 lbs./hr.	82009001 (B)
1050 - 1200*	1000	square flange	75 lbs./hr.	82010001 (B)

Naturally Aspirated Applications:				
Chevrolet Big Block V8; Std. Deck; Rectangular Port Heads				
385 - 480*	1000	square flange	30 lbs./hr.	82104001 (B)
480 - 575*	1000	square flange	36 lbs./hr.	82105001 (B)
575 - 670*	1000	square flange	42 lbs./hr.	82106001 (B)
670 - 800*	1000	square flange	50 lbs./hr.	82107001 (B)
800 - 880*	1000	square flange	55 lbs./hr.	82108001 (B)
880 - 1050*	1000	square flange	65 lbs./hr.	82109001 (B)
1050 - 1200*	1000	square flange	75 lbs./hr.	82110001 (B)
575 - 670*	2000	Dominator flange	42 lbs./hr.	82306001 (B)
670 - 800*	2000	Dominator flange	50 lbs./hr.	82307001 (B)
800 - 880*	2000	Dominator flange	55 lbs./hr.	82308001 (B)
880 - 1050*	2000	Dominator flange	65 lbs./hr.	82309001 (B)
1050 - 1200*	2000	Dominator flange	75 lbs./hr.	82310001 (B)
1360 - 1520*	2000	Dominator flange	95 lbs./hr.	82312001 (B)

Naturally Aspirated Applications:				
Chevrolet Big Block V8; Tall Deck; Rectangular Port Heads				
385 - 480*	1000	square flange	30 lbs./hr.	82204001 (B)
480 - 575*	1000	square flange	36 lbs./hr.	82205001 (B)
575 - 670*	1000	square flange	42 lbs./hr.	82206001 (B)
670 - 800*	1000	square flange	50 lbs./hr.	82207001 (B)
880 - 1050*	1000	square flange	65 lbs./hr.	82209001 (B)
1050 - 1200*	1000	square flange	75 lbs./hr.	82210001 (B)
575 - 670*	2000	Dominator flange	42 lbs./hr.	82406001 (B)
670 - 800*	2000	Dominator flange	50 lbs./hr.	82407001 (B)
880 - 1050*	2000	Dominator flange	65 lbs./hr.	82409001 (B)
1050 - 1200*	2000	Dominator flange	75 lbs./hr.	82410001 (B)
1360 - 1520*	2000	Dominator flange	95 lbs./hr.	82412001 (B)

(*) A brake specific fuel consumption (BSFC) of .45 and 90% duty cycle is used for the maximum horsepower recommendation.

NOTE: Downloadable base fuel maps are available at www.holley.com.

STEALTH RAM™ MPFI Power Pack Kits

This kit simplifies the task of converting a factory EFI system to a Stealth Ram. All that's needed is any factory or aftermarket ECU, wiring harness, and fuel pump. It doesn't get much easier... or more powerful.

System features:

- Fits early and late(*) model 23° Chevrolet cylinder heads
- Designed to use GM TPI throttle and transmission cables and brackets

(*) Requires angled spacers, P/N 90748

Systems include:

- Upper and lower intake manifolds
- 58mm billet throttle body
- Bright clear anodized aluminum fuel rails
- Fuel injectors
- Fuel pressure regulator
- TPS, MAP, coolant, air temperature and oxygen sensors
- No EGR provision
- Detailed installation and tuning manuals

Specifications:

- Height is 10-1/4"
- Shipping weight is approximately 45 lbs.



Part #	STEALTH RAM™ Kit Description	Horsepower Range*
81503001 ^(B) ⚡	Satin finish kit with 24 pph injectors	300 - 385
81504001 ^(B) ⚡	Satin finish kit with 30 pph injectors	385 - 480
81505001 ^(B) ⚡	Satin finish kit with 36 pph injectors	480 - 575
81506001 ^(B) ⚡	Satin finish kit with 42 pph injectors	575 - 670
81403001 ^(B) ⚡	Polished kit with 24 pph injectors	300 - 385
81404001 ^(B) ⚡	Polished kit with 30 pph injectors	385 - 480
81405001 ^(B) ⚡	Polished kit with 36 pph injectors	480 - 575
81406001 ^(B) ⚡	Polished kit with 42 pph injectors	575 - 670

(*) A brake specific fuel consumption (BSFC) of .45 and 90% duty cycle is used for the maximum horsepower recommendation.

HOW TO CHOOSE A CARB
STREET CARBURETORS
SUPERCHARGER CARBURETORS
RACE CARBURETORS
MARINE CARBURETORS
CARB SERVICE PARTS & ACCESSORIES
FUEL INJECTION
THROTTLE BODIES
FUEL PUMPS
INTAKE MANIFOLDS
CYLINDER HEADS
SYSTEMAX
ENGINE DRESS-UP
MERCHANDISING
TECHNICAL INFORMATION
INDEX



534-120

ECU-Commander

The most advanced fuel management / engine controller available today. See elsewhere for a complete description of features and capabilities of this remarkable unit **Part # 534-120** (Automotive)
Part # 534-181 (Marine)



890-160

Distributor Part # 890-160

- Billet construction
- Performance pick-up
- Plug & play with Commander 950 (requires 534-138 harness and Factory GM coil connector)
- Direct replacement for 1985-up GM small cap computer controlled HEI
- Allows complete timing control using Commander 950



534-83

Fuel Injector Bungs

- 1/pkg **Part # 534-82**
- 4/pkg **Part # 534-83**
- 6/pkg **Part # 534-84**
- 8/pkg **Part # 534-85**



534-112

Fuel Injector Connectors & Terminals

8/ pkg. (for Holley top feed injectors) **Part # 534-112**



534-104

Fuel Injector O-ring & Retainers

- Delphi/Holley fuel injector O-ring 16/pkg **Part # 534-104**
- Bosch fuel injector retainer 8/pkg **Part # 534-102**
- Delphi/Holley fuel injector retainer 8/pkg **Part # 534-103**



534-102

Fuel Lines & Rails

Fuel Line, Fuel Rail Crossover – Small Block Chevrolet V-8 Fits Holley MPI Manifolds **Part # 9900-144**



534-103

Fuel Line, Fuel Rail Crossover – Big Block Chevrolet V-8 Fits Holley MPI Manifolds **Part # 9900-145**



9900-144

Left & Right Hand Fuel Rails – Small Block Chevrolet V-8 Fits Holley MPI Manifolds **Part # 9900-147**

Left & Right Hand Fuel Rails – Big Block Chevrolet V-8 Fits Holley MPI Manifolds **Part # 9900-149**

Left & Right Hand Fuel Rails, Crossovers, Fittings, Hardware Small Block Chevrolet V-8 - Fits Holley MPI Manifolds. **Part # 9900-172**



9900-173

Fuel Lines & Rails

Left & Right Hand Fuel Rails, Crossovers, Fittings, Hardware Big Block Chevrolet V-8 - Fits Holley MPI Manifolds. **Part # 9900-173**

STEALTH RAM™ fuel rail kit . . . **Part # 534-185** w/ non-adjustable regulator
Part # 534-186 w/ adjustable regulator

STEALTH RAM™ fuel rail kit for vortec kits **Part # 534-192** w/ non-adjustable regulator
Part # 534-193 w/ adjustable regulator



108-4

Universal fuel rail kit - 12" length **Part # 534-78**

Universal fuel rail kit - 18" length **Part # 534-79**

Universal fuel rail kit - 36" length **Part # 534-80**



12-920

Air Cleaner Gasket . . . Part # 108-4

Electric Fuel Pump . . . Part # 12-920

See page 132 for specifications



534-26

40 Amp. Relay Part # 534-26

Sensors

Air Temperature **Part # 9920-107**
Coolant Temperature **Part # 534-10**



538-13

Map Sensor

Naturally-aspirated motors - (1 bar) **Part # 538-24**

Forced induction - up to 14.7 PSI boost - (2 bar) . . . **Part # 538-13**

Forced induction - 14.7 to 29.4 PSI boost - (3 bar) . . . **Part # 538-23**



43-106

Oxygen Sensor

Oxygen sensor **Part # 43-106**

Wide Band Oxygen sensor replacement (NTK 1st generation) **Part # 534-190**

Wide Band Oxygen sensor replacement (NTK 2nd generation) **Part # 534-194**

Wide Band Oxygen sensor replacement (Bosch) **Part # 534-198**

Sensor bung. **Part # 534-49**



534-49

Throttle Position Sensor

2000 CFM throttle body . . . **Part # 9920-110**



9920-104

Software

Commander 950 ECU (Mapping & Set-up) **Part # 534-144**

Pro-Jection MPFI w/ E-Prom. . **Part # 534-117**

Pro-Jection (version 3.38) . . **Part # 534-74**

Pro-Jection TBI w/ E-Prom . . **Part # 534-77**



534-74

Throttle Body Assemblies

Universal 1000 CFM w/ IAC . . . Part # 9900-171

Universal 2000 CFM. Part # 112-538



112-538

Commander 950 ECU Primary

Wiring Harness Part # 534-142

ECU-to-sensors (Holley MPI systems)



534-129

Commander 950 ECU Injector

Wiring Harness

Holley MPI system
(over fuel rail routing) Part # 534-129

Holley MPI system (over intake
plenum routing) Part # 534-130



534-138

Commander 950 ECU Accessory

Wiring Harness

Cooling fan relay Part # 534-134

Crank trigger w/
magnetic pick up Part # 534-135

Knock sensor Part # 534-136

Chevrolet HEI Distributor. Part # 534-138

Ford TFI distributor. Part # 534-139



508-17

Base Plate & Gasket Sealing Kit

1000 CFM throttle body Part # 508-17

2000 CFM throttle body Part # 508-18



112-560

Block-off Plate, IAC . . . Part # 112-560

Morse Throttle Cable Bracket
(marine item only). Part # 9902-108



9902-108

MAP Sensor Bracket . . . Part # 9902-104

TH-700R4
Transmission Bracket. . . . Part # 20-113



20-113

Fuel Filter -
TBI post filter (metal) . . Part # 562-1

Fuel Filter Element
Prefilter (plastic) Part # 562-3



562-1

Fittings
90° & Schrader Valve
has 1/8" NPT Tap) Part # 9900-163

Regulator Part # 9906-127

Swivel #6 to 3/8" Hose Barb. Part # 9906-143

Swivel 90° Male to SAE 37° #6. Part # 9906-118

Tee 180° Male to 2x SAE 37° #6. Part # 9906-126



9900-163

Base Throttle Body Gasket

1000 CFM throttle body Part # 9910-101

2000 CFM throttle body Part # 9910-102



9910-101

INTAKE MANIFOLDS SMALL BLOCK CHEVROLET V-8

350 Early & Late Cylinder Heads

4bbl square flange design
(automotive) Part # 9901-101-1



9910-102

STEALTH RAM™

Satin finish. Part # 7540

Polished finish Part # 7540P

Vortec satin finish Part # 7542

Vortec polished finish Part # 7542P

350 Vortec/Gen 1 Cylinder Heads

4 bbl square flange. Part # 9901-107



9910-101-1

INTAKE MANIFOLDS BIG BLOCK CHEVROLET V-8

Oval Port Cylinder Heads

Standard deck w/ square
flange (automotive) Part # 9901-209



9910-201

Rectangular Port Cylinder Heads

Standard deck w/ square
flange (automotive) Part # 9901-201

Standard deck w/ DOMINATOR
flange (automotive) Part # 9901-202

Tall deck w/ square
flange (automotive) Part # 9901-203

Tall deck w/ DOMINATOR
flange (automotive) Part # 9901-204

Fuel Pump Block-Off Plate

Chevrolet Small Block V8,
Chevrolet Big Block V8. Part # 12-814



12-814

HOW TO CHOOSE A CARB
STREET CARBURETORS
SUPERCHARGER CARBURETORS
RACE CARBURETORS
MARINE CARBURETORS
CARB SERVICE PARTS & ACCESSORIES
FUEL INJECTION
THROTTLE BODIES
FUEL PUMPS
INTAKE MANIFOLDS
CYLINDER HEADS
SYSTEMAX
ENGINE DRESS-UP
MERCHANDISING
TECHNICAL INFORMATION
INDEX

Holley Throttle Body Fuel Injection Systems

General Information

Holley offers two barrel and four barrel universal stand-alone throttle body injection systems that will replace a carburetor on a non-computerized vehicle.

Two barrel systems are available with either the Holley digital "D" ECU or the new Commander 950 ECU. The "D" ECU does not have the ability to be programmed or mapped with a customized fuel map via lap top computer. Rather it uses a basic, pre-programmed performance fuel curve that has a wide range of adjustability. It is intended primarily for stock or very mildly modified vehicles with V8 engines that can maintain at least 15" vacuum at idle (A/T idling in gear). The Commander 950 ECU is a highly versatile and sophisticated ECU design that enables the user to program a customized fuel map for the motor, through use of a lap top computer.

Two barrel throttle body systems equipped with Commander - 950 can work on any 4 cylinder, even fire 6 cylinder or V8 engines rated not more than 275 horsepower. Special design Holley small block Chevrolet V8 manifolds are also available to accept the two barrel throttle body bolt pattern which is the same as the GM throttle body. Two barrel manifold adapter kits are available for those who wish to retain their stock two barrel intake manifold. Experience, however, has shown that the best performance results are obtained using a aftermarket dual plane intake manifold.

Four barrel systems are available only with the Commander 950 ECU. The Commander 950 ECU can program a multitude of engine parameters with the use of Windows-based software and a lap top computer. A complete explanation of the 950 Commander ECU is contained elsewhere in this section.

Holley four barrel throttle bodies utilize a square flange and are available in four sizes:

- 650 CFM for engines rated 150 - 325 horsepower
- 700 CFM for engines rated 250 - 440 horsepower
- 900 CFM for engines rated 375 - 525 horsepower
- 900 CFM for engines rated 450 - 600 horsepower



Pro-Jection 2D Electronics

Pro-Jection "D" electronics contain a basic performance fuel curve that has a wide range of adjustability. "D" electronics monitor engine RPM and processes a stream of information inputs from the throttle position and engine temperature sensors. From these inputs the "D" system automatically changes, adjusts and modifies the fuel delivery to maintain the fuel curve. Further refinement of the fuel curve is possible by adjusting the knobs on the ECU. The payoff for all this electronic capability is excellent start up, driveability, power and economy. "D" Pro-Jection is designed to be used on stock, or mildly modified engines with at least 15" vacuum at idle (A/T idling in gear).

Commander 950® Electronics

The awesome power and capability of the Holley Commander 950 ECU is available with any of the Holley throttle body fuel injection systems. The advantages of the 950 are especially obvious for those who need or want a customized fuel curve. Such capability would be desirable when installing a fuel injection system on a modified motor. Stock fuel curves, in such instances, may not have enough functional variability to accommodate the fuel requirements of such an engine over its operational range. The Commander 950 ECU, however, has all the power and capability needed to accomplish this task. The software included with each Commander 950 enables the user to view the fuel map on his laptop computer and modify it, accordingly. Pre-set, downloadable, base fuel maps are available at www.holley.com. A true, custom fuel map is required for the ultimate in performance and driveability. Features and benefits of the Commander 950 have been detailed earlier in this section.



Commander 950® 4-bbl Throttle Body Fuel Injection Systems



Features

- Commander 950 ECU
- Complete stand-alone, speed-density systems
- Square flange throttle body
- Die cast aluminum throttle body has a tumble-polished finish
- Allows infinite adjustment of the fuel map via your IBM-compatible PC
- Programmable spark curve (see system requirement)
- MAP, coolant and air temp. sensors
- Oxygen sensor
- Idle air control valve
- 45 PPH injectors used with 650 CFM throttle body
- 65 PPH injectors used with 700 CFM throttle body
- 75 PPH injectors used with 900 CFM throttle body (950-24S)
- 85 PPH injectors used with 900 CFM throttle body (950-21S)
- Self-priming, in-line electric gerotor fuel pump
- 5" airhorn facilitates use of performance carburetor air cleaner assembly
- Designed for bolt on, plug-in installation
- Installed height of throttle body is no greater than a carburetor
- Detailed installation/instruction booklet is included

System Requirements

- Four barrel (square flange) intake manifold (see Intake manifolds in this catalog)
- IBM-compatible personal laptop computer with WIN 3.1, 95, 98, NT, 2000ME, XP software
- The programmable timing feature of this system is available either by:
 1. Using one of the following distributors: 1980-1/2 through 1990 GM 7-pin (coil-in-cap); Holley 890-160 distributor, see pg 108; 1984-96 GM (external coil); 1984 - later Ford 7-wire TFI. Use wiring harness adapter P/N 534-138 for GM distributors and P/N 534-139 for the Ford distributor.
 2. Using a magnetic or Hall Effect crank trigger system when used in conjunction with an after market CD ignition system.

Available Separately

- GM TH-700R4 transmission cable bracket **Part # 20-121**
- Holley 4-bbl intake manifold (see Intake manifolds in this catalog)
- Dual tank installation kit for light duty trucks and motor homes, **Part # 534-38**
- Performance air cleaner (a selection of Holley air cleaners is listed elsewhere in this catalog)

Holley offers a complete line of 4 bbl Commander 950 TBI systems for engines from 150 to 600 horsepower*.

Throttle body fuel injection offers all of the benefits of electronic fuel injection in an easy to install and cost effective package. The Commander 950 provides complete laptop programmability of all fuel and ignition timing parameters.

The throttle body utilizes a progressive linkage for optimum off-idle driveability. The throttle body includes an adjustable regulator and high quality fuel injectors to guarantee years of trouble-free service.

Systems include most components needed for installation including ECU, wiring harness, software, throttle body, fuel pump and filters, sensors, and other misc. components.

NOTE: These systems are designed only for fuel and spark management. Features such as cruise control, transmission control, air conditioning, ABS, etc., are not controlled by the Commander 950.

Description	CFM	Part#
4 cyl., even fire 6 cyl., V8 engine rated 150-325 horsepower*	650	950-23S (B)
4 cyl., even fire 6 cyl., V8 engine rated 250-440 horsepower*	700	950-22S (B)
4 cyl., even fire 6 cyl., V8 engine rated 375-525 horsepower*	900	950-24S (B)
4 cyl., even fire 6 cyl., V8 engine rated 450-600 horsepower*	900	950-21S (B)

Benefits

- Fantastic driveability
- Unbelievable throttle response
- Increased power
- Improved engine efficiency
- Great looks

Commander 950® 2-bbl Throttle Body Fuel Injection Systems

Commander 950 two barrel throttle body fuel injection systems offer the owners with smaller engines the same opportunity of precise fuel and ignition timing control that others enjoy. Any 4, 6, or 8 cylinder even fire engine can be retrofitted with these systems. Two systems are available, a 670 CFM unit with two 85 lb/hr injectors for engines up to 275 horsepower and a 400 CFM unit with two 65 lb/hr injectors for engines up to 225 horsepower. Both units have an adjustable regulator.

These systems offer all the same features as all other Commander 950 systems such as idle air control motors, closed loop control, speed density operation, ignition timing control, and full laptop programmability.

Adapters are included for both square and spread bore intake manifolds. Other applications will require adapters.

NOTE: These systems are designed only for fuel and spark management. Features such as cruise control, transmission control, air conditioning, ABS, etc., are not controlled by the Commander 950.

Available Separately

- GM TH-700R4 transmission cable bracket
 - Part # 20-96 (factory 4-bbl intake manifold)
 - Part # 20-97 (aftermarket performance 4-bbl intake manifold) and # 20-121 (all)
- Holley 2-bbl throttle body intake manifold adapters
 - Part # 17-47 (Holley 2300/Motorcraft 2-bbl flange)
- Holley 2-bbl throttle body small block Chevrolet
 - aluminum intake manifolds Part # 300-49 (1957-86 all and 1987-later with aluminum cylinder heads)
 - Part # 300-66 (1987-later with cast iron cylinder heads)
- Dual tank installation kit for light-duty trucks - Part # 534-37



Description	CFM	Part#
4 cyl., even fire 6 cyl., V8 engine rated not more than 225 horsepower*	400	950-19S (B)
4 cyl., even fire 6 cyl., V8 engine rated not more than 275 horsepower*	670	950-20S (B)

System Requirements

- 4 cylinder, Even Fire 6 cylinder or V8
 - 400 CFM: not more than 225 horsepower
 - 670 CFM: not more than 275 horsepower
- IBM-compatible personal laptop computer with WIN 3.1, 95, 98, NT, 2000ME, and XP software
- The programmable timing feature of this system is available either by:
 1. Using one of the following distributors: 1980-1/2 through 1990 GM 7-pin (coil-in-cap); 1984-96 GM (external coil); 1984 - later Ford 7-wire TFI. Use wiring harness adapter P/N 534-138 for GM distributors and P/N 534-139 for the Ford distributor.
 2. Using a magnetic or Hall Effect crank trigger system when used in conjunction with a aftermarket CD ignition system.

Marine Commander 950® 4-bbl Throttle Body Fuel Injection Systems



For technical information on this system ,see page 199

650 CFM	Part # 950-53
Any carbureted, Even-Fire V6* or V8 engine Engines rated 150 - 300 horsepower	
700 CFM	Part # 950-52
Any carbureted, Even-Fire V6* or V8 engine Engines rated 225 - 400 horsepower	
900 CFM	Part # 950-51
Any carbureted, Even-Fire V6* or V8 engine Engines rated 350 - 500 horsepower	

HOW TO CHOOSE A CARB
 STREET CARBURETORS
 SUPERCHARGER CARBURETORS
 RACE CARBURETORS
 MARINE CARBURETORS
 CARB SERVICE PARTS & ACCESSORIES
 FUEL INJECTION
 THROTTLE BODIES
 FUEL PUMPS
 INTAKE MANIFOLDS
 CYLINDER HEADS
 SYSTEMS
 ENGINE DRESS-UP
 MERCHANDISING
 TECHNICAL INFORMATION
 INDEX

670 CFM Pro-Jection® Part # 502-20S

GM, Chrysler, Ford & AMC V-8s



Application

- Small block V-8s up to 275 H.P.
- Big block V-8s up to 275 H.P.
- No 4 or 6 cylinders

Features

- A complete "stand-alone" system.
- Retro-fits only carbureted, non-computerized V-8 engines.
- Die cast aluminum throttle body.
- Dual 85 lb./hour injectors.
- 12 - 22 PSI adjustable pressure regulator.
- Digital ECU is user-adjustable for: Idle, Accelerator pump, Main, High RPM, Choke
- Self-priming, in-line electric gerotor fuel pump is rated at 300 lb./hr. @ 15 PSI.
- Wiring harness is designed for "plug-in" installation. It's temperature-insulated & weather-sealed.
- Adjustable fast idle solenoid.
- Installed height of TBI is no greater than standard carburetor.
- Detailed installation instruction booklet is included

Benefits

- Improved driveability
- Fantastic throttle response
- Greater fuel economy
- Increased power

No Laptop Required!

System Requirements

- Non-computerized V-8 engine of not more than 275 H.P.

Available Separately

- GM TH-700R4 transmission cable bracket
 - P/N: **20-96** (factory 4-bbl. intake manifold)
 - P/N: **20-97** (aftermarket 4-bbl. intake manifold)
- Holley 2-bbl.-manifold-2 bbl.-Pro-Jection adapters
 - P/N: **17-47** (Holley 2300/Motorcraft 2-bbl. flange)
- Holley 2-bbl. Pro-Jection intake manifold for small block Chevrolet V-8s
 - P/N: **300-49** (1957-86 all & 1987-later with aluminum cylinder heads)
 - P/N: **300-66** (1987-later with cast iron cylinder heads)
- Dual tank installation kit for light-duty trucks
 - P/N: **534-37**
- Closed loop kit
 - P/N: **534-54**
- Rich/Lean indicator for vehicles w/o oxygen sensor
 - P/N: **534-50**
- Rich/Lean indicator for vehicles with oxygen sensor
 - P/N: **534-51**

Marine Pro-Jection® 2-bbl Throttle Body Fuel Injection Part # 700-21



Features common to both 2-bbl systems

- 85 lb./hr. injectors
- Fuel pressure regulator , fuel pressure is pre-set at 21 PSI fuel pressure is adjustable from 12 - 25 PSI
- Gerotor-type 12-Volt electric marine fuel pump flows 300 lbs. of fuel per hour at 15 PSI
- Stainless steel flame arrestor (5 3/4" x 3") is included
- Adapters included for either spread bore or square flange 4-bbl intake manifolds
- Wiring harness is designed for "plug-in" installation, temperature insulated & weather sealed
- Includes complete and detailed installation instructions.

All carbureted V8 engines

- Complete stand-alone system
- Engines w/o computer control
- Engines rated up to 275 horsepower
 - At least 15" of engine vacuum at idle
- 670 CFM die cast aluminum throttle body
- Digital "2D" computer (ECU) is rugged and reliable
- ECU provides adjustments for
 - Idle, Accelerator pump
 - Main jet, High RPM jet, Choke

System Requirements

- Adequate hatch clearance — overall height of the installed system is approximately 1" higher than the carburetor.



HOW TO CHOOSE A CARB
STREET CARBURETORS
SUPERCHARGER CARBURETORS
RACE CARBURETORS
MARINE CARBURETORS
CARB SERVICE PARTS & ACCESSORIES
FUEL INJECTION
THROTTLE BODIES
FUEL PUMPS
INTAKE MANIFOLDS
CYLINDER HEADS
SYSTEMAX
ENGINE DRESS-UP
MERCHANDISING
TECHNICAL INFORMATION
INDEX



A

A. Adapter - Air Cleaner Part # 17-14
4-bbl Pro-Jection systems



B.

B. Adapter - TBI (spread bore to TBI flange) Part # 17-41
2-bbl Pro-Jection



C.

C. Adapter - TBI (square bore to TBI flange) Part # 17-45
2-bbl Pro-Jection



D.

D. Adapter - TBI (square bore to spread flange) . . . Part # 17-6
2-bbl Pro-Jection



E.

E. Adapter - TBI (2300 2-bbl flange to TBI flange) Part # 17-47
2-bbl Pro-Jection



F

F. Bracket - Transmission Cable (GM TH-700R4) Part # 20-96
2-bbl Pro-Jection, P/Ns 502-1, 502-2 Chevrolet small block V-8 with original equipment 4-bbl intake manifold



G.

G. Bracket - Transmission Cable (GM TH-700R4) Part # 20-97
2-bbl Pro-Jection, P/Ns 502-1, 502-2 Aftermarket 4-bbl intake manifold



H.

H. Closed Loop Kit Part # 534-27
1-bbl, 2-bbl, 4-bbl Pro-Jection analog systems



I.

I. Closed Loop Kit Part # 534-54
1-bbl, 2-bbl digital Pro-Jection



J.

J. Diaphragm, Fuel Pressure Regulator . . Part # 512-1
1-bbl, 2-bbl, 4-bbl Pro-Jection



K.

K. Distribution Ring, Air Part # 508-10



L.

L. Distribution Ring, Air Part # 508-12
4-bbl Pro-Jection systems



M.

M. Injector O-Ring Kit . Part # 508-19



N.

N. Dual Tank Fuel Pump Kit Part # 534-37
1-bbl Pro-Jection, P/Ns 501-1, 501-2
2-bbl Pro-Jection, P/Ns 502-1, 502-2



O.

O. Dual Tank Fuel Pump Kit Part # 534-38
4-bbl Pro-Jection (All), 950 MPFI/4-bbl TBI)



P.

P. Electronic Control Unit (ECU)
2-bbl Pro-jection Part # 534-55
2-bbl Pro-jection (MARINE) Part # 534-33



Q.

Q. Electronic Control Unit (ECU) Part # 534-72
1-bbl digital Pro-Jection, P/N 501-12



R.

R. Filter, Fuel - Pump (plastic) Part # 562-3
All Pro-Jection systems



S.

S. Filter, Fuel - TBI (metal) Part # 562-1
All Pro-Jection systems



T.

T. Gasket, Air Horn Part # 508-1
1-bbl replacement TBIs, P/Ns 500-1, 500-2, 500-3, 500-4, 500-5; 1-bbl Pro-Jection, P/Ns 501-1, 501-2



U.

U. Gasket, Air Horn Part # 108-4
2-bbl replacement TBIs, P/Ns 502-3, 502-4, 502-5, 502-6, 502-7, 502-8; 2-bbl Pro-Jection, P/Ns 502-1, 502-2; 4-bbl Pro-Jection systems (all)



V.

V. Gasket, 1-bbl TBI Flange (O.E. manifold/ 1.68" bore) Part # 508-2
1-bbl replacement TBIs, P/Ns 500-1, 500-2, 500-3, 500-4, 500-5



W.

W. Gasket, 1-bbl TBI Flange (Holley manifold/ 2.00" bore) Part # 508-3
1-bbl replacement TBIs, P/Ns 500-1, 500-2, 500-3, 500-4, 500-5

A. Gasket, 2-bbl TBI Flange (O.E. manifold/ 1.68" bores) Part # 508-7

2-bbl replacement TBI, P/Ns 502-3

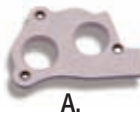

B. Gasket, 2-bbl TBI Flange (O.E. manifold/ 2.00" bores) Part # 508-11

2-bbl replacement TBI, P/Ns 502-4, 502-5, 502-6, 502-7, 502-8

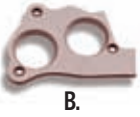

C. Gasket, Flange. Part # 508-5

2-bbl Pro-Jection, P/N 502-1 Spread bore manifold to



D. Flange Gasket

2-bbl Pro-jection, P/N 502-2 Square bore manifold to P/N 17-6 adapter. . . Part # 508-9



E. Fuel Filter. Part # 562-1

TBI (metal)



F. Gasket, 2-bbl TBI Flange / Adapter Part # 508-6

2-bbl Pro-Jection, P/Ns 502-1, 502-2; 2 x 2 Pro-Jection, P/N 502-2211; 2-bbl TBI flange to either P/Ns 17-41, 17-45 or 517-1 adapters



G. Gasket, 4-bbl TBI Flange (1/16" thick) Part # 108-10

All 4-bbl Pro-Jection systems



H. Gasket, 4-bbl TBI Flange (5/16" thick) Part # 108-12

All 4-bbl Pro-Jection systems



I. Gasket, 1-bbl TBI Flange/ Adapter Part # 508-15

1-bbl Pro-Jection, P/N's 501-2, 501-12



J. Gasket, 2-bbl Carter BBD Flange to 1-bbl TBI Adapter . . Part # 508-16

1-bbl Pro-Jection, P/N's 501-2



K. Gasket, 1-bbl TBI Air Cleaner Adapter to O.E. Air Cleaner Part # 508-14

1-bbl Pro-Jection, P/N's 501-1, 501-2



L. Gasket, Idle Air Control Motor Part # 508-8

All "D" and "Di" Pro-Jection systems



M. Idle Air Control Motor. Part # 543-2

1-bbl and 2-bbl replacement TBIs



N. Idle Air Control Motor. Part # 543-105

All digital Pro-Jection systems



O. Injector, Fuel (90 PPH). Part # 522-40

1-bbl Pro-Jection, P/Ns 501-1, 501-2



P. Injector, Fuel, Performance, Commander 950 systems

32 PPH @ 12 PSI; 45 PPH @ 21 PSI Part # 522-81

45 PPH @ 12 PSI; 65 PPH @ 21 PSI Part # 522-54

50 PPH @ 12 PSI; 72 PPH @ 21 PSI Part # 522-80

60 PPH @ 12 PSI; 85 PPH @ 21 PSI Part # 522-43



Q. Injector, O-ring Kit

Commander 950 TBI new style injector (O-rings only) Part # 508-19

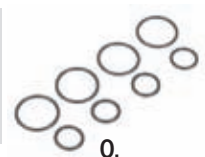

Injector, Retaining Plate with Air Cleaner Stud

2-bbl throttle body, Commander 950 systems Part # 534-165

4-bbl throttle body, Commander 950 systems Part # 534-166

R. Injector, Wiring Harness, Commander 950 Systems

2-bbl throttle body Part # 534-167

4-bbl throttle body Part # 534-168



S. Injector Pod, Replacement, Commander 950 Systems

2-bbl throttle body Part # 534-162

4-bbl throttle body (does not include injectors) . . . Part # 534-163



HOW TO CHOOSE A CARB
STREET CARBURETORS
SUPERCHARGER CARBURETORS
RACE CARBURETORS
MARINE CARBURETORS
CARB SERVICE PARTS & ACCESSORIES
FUEL INJECTION
THROTTLE BODIES
FUEL PUMPS
INTAKE MANIFOLDS
CYLINDER HEADS
SYSTEMAX
ENGINE DRESS-UP
MERCHANDISING
TECHNICAL INFORMATION
INDEX



A.

A. Injection Pod Upgrade Kit for Pro-Jection Throttle Bodies

2-bbl throttle body **Part # 534-170**

4-bbl throttle body **Part # 534-169**

(upgrades "old-style" throttle body for new performance injectors; includes injector wiring harness and retaining plate)



B.

B. Injector Caps, Replacement Part # 534-100

2-bbl Pro-Jection



C.

C. Kit, Renew Part # 503-1

1-bbl replacement TBIs; 1-bbl Pro-Jection systems

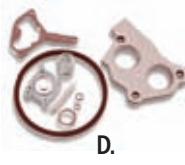

D.

D. Kit, Renew Part # 503-2

2-bbl replacement TBI, P/N 502-3



E.

E. Kit, Renew Part # 503-5

2-bbl replacement TBIs, P/Ns 502-4, 502-5, 502-6, 502-7, 502-8



F.

F. Kit, Renew Part # 503-3

2-bbl Pro-Jection (All); 2 x 2 Pro-Jection



G.

G. Kit, Renew Part # 503-6

4-bbl Pro-Jection (All)



H.

H. Lever, Throttle Extension (Chrysler) Part # 20-7

2-bbl Pro-Jection (All); 2 x 2 Pro-Jection;
4-bbl Pro-Jection (All)



J.

I. Linkage kit, 4-bbl throttle body

Progressive secondary action **Part # 534-160**

1:1 secondary action **Part # 534-161**



K.

J. Plate, Fuel Pump Block-Off Part # 12-813

Chrysler - Big Block V-8; Chrysler - Small Block V-8

K. Plate, Fuel Pump Block-Off Part # 12-814

Chevrolet - Small Block V-8;

Chevrolet - Big Block V-8



L.

L. Pump, Electric Fuel (258 PPH @ 15 PSI) . . . Part # 12-927

All 1-bbl Pro-Jection; All 2-bbl Pro-Jection



M.

M. Pump, Electric Fuel . . Part # 12-920

All 4-bbl Pro-Jection (480 PPH @ 15 PSI);
All MPI systems (402 PPH @ 45 PSI)



N.

N. Relay, 40 Amp Part # 534-26

All Pro-Jection Systems



O.

O. Rich/Lean Indicator . Part # 534-50

without oxygen sensor



P.

P. Rich/Lean Indicator . Part # 534-51

with oxygen sensor



Q.

Q. Sensor, Air Charge . . Part # 534-46

All digital Pro-Jection Systems



R.

R. Sensor, Coolant Temperature Part # 534-2

All 4-bbl analog Pro-Jection systems
P/N 502-20 digital 2-bbl Pro-Jection



S.

S. Sensor, Coolant Temperature Part # 534-10

All 4-bbl digital Pro-Jection systems



T.

T. Sensor, MAP

All digital Pro-Jection systems -
4D & 4DI 2-bar **Part # 538-13**

All Commander 950 systems -
1 bar **Part # 538-24**



U.

U. Sensor, Oxygen. Part # 43-106

All digital Pro-Jection systems;
Closed loop kit, P/N 534-27



V.

V. Sensor, Throttle Position. Part # 543-1

1-bbl replacement TBIs, P/Ns 500-1, 500-3, 500-5
1-bbl Pro-Jection, P/Ns 501-1, 501-2



A.

A. Sensor, Throttle Position Part # 543-3

1-bbl replacement TBIs, P/Ns 500-2, 500-4
2-bbl Pro-Jection, P/Ns 502-1, 502-2, 502-20
2 x 2 Pro-Jection, P/N 502-2211



B.

B. Sensor, Throttle Position Part # 543-29

2-bbl replacement TBIs, P/Ns 502-3, 502-4, 502-5, 502-6, 502-7, 502-8; 4-bbl Pro-Jection, P/Ns 504-1, 504-2, 504-11, 504-12, 504-13, 504-21, 504-22, 504-23, 950-21, 950-22, 950-23 & 950-24



C.

C. Software, Interactive Mapping Part # 534-44-1

(3.5" IBM diskette – Windows 3.x/95 and DOS 6.0)
64 point acceleration compensation map
4-bbl Pro-Jection, P/Ns 504-21, 504-22, 504-23



D.

D. Solenoid, Fast Idle . . Part # 46-74

All 2-bbl and 4-bbl analog Pro-Jection systems
1-bbl and 2-bbl Digital systems



E.

E. TBI Assembly (670 CFM). Part # 500-6S

2-bbl Pro-Jection, P/Ns 502-1, 502-2

TBI Assembly (900 CFM) Part # 500-16S

4-bbl Pro-Jection, P/Ns 504-11, 504-21



2-bbl.

TBI Assembly (700 CFM) Part # 500-17S

4-bbl Pro-Jection, P/Ns 504-12, 504-22

TBI Assembly (650 CFM) Part # 500-18S

4-bbl Pro-Jection, P/Ns 504-13, 504-23



4-bbl.

Throttle Body Assemblies, Commander 950™ Systems

650 CFM 4-bbl w/
45 PPH injectors Part # 534-171

700 CFM 4-bbl w/
65 PPH injectors Part # 534-172

900 CFM 4-bbl w/
75 PPH injectors Part # 534-187

900 CFM 4-bbl w/
85 PPH injectors Part # 534-173



F.

Throttle Body Assemblies, TBI Systems, Marine
670 CFM 2-bbl system
P/N 700-21 Part # 500-13

900 CFM 4-bbl system
P/N 700-51 Part # 500-19

700 CFM 4-bbl system
P/N 700-21 Part # 500-20

F. Wiring Harness Part # 534-25-1

1-bbl Pro-Jection, 2-bbl Pro-Jection



G.

G. Wiring Harness Part # 534-43

4-bbl Pro-Jection 4D & 4DI, P/Ns 504-11, 504-12, 504-13, 504-21, 504-22, 504-23



H.

H. Wiring Harness Adapter Part # 534-23

All analog 2-bbl Pro-Jections with old-style ECU with ribbed/finned housing. Adapter allows connection either to "newer" analog or "state-of-the-art" digital ECU.



I.

I. Wiring Harness Adapter Part # 534-47

All digital interactive (Di) Pro-Jection & 950 systems. Allows connection to GM distributor for ignition control feature.



J.

J. Wiring Harness Adapter Part # 534-48

All digital interactive (Di) Pro-Jection & 950 systems. Allows connection to Ford distributor for ignition control feature.



K.

K. Wiring Harness, Closed Loop Part # 534-56

Digital 2-bbl Pro-Jection



L.

L. Wiring Harness, Computer Cable DB-9 Part # 534-45

All digital interactive (Di) Pro-Jection systems. Allows computer hookup for tuning purposes.



M.

M. Wiring Terminals Package Part # 534-4

2-bbl Pro-Jection, P/Ns 502-1, 502-2

HOW TO CHOOSE A CARB
STREET CARBURETORS
SUPERCHARGER CARBURETORS
RACE CARBURETORS
MARINE CARBURETORS
CARB SERVICE PARTS & ACCESSORIES
FUEL INJECTION
THROTTLE BODIES
FUEL PUMPS
INTAKE MANIFOLDS
CYLINDER HEADS
SYSTEMAX
ENGINE DRESS-UP
MERCHANDISING
TECHNICAL INFORMATION
INDEX

HOW TO CHOOSE A CARB
STREET CARBURETORS
SUPERCHARGER CARBURETORS
RACE CARBURETORS
MARINE CARBURETORS
CARB SERVICE PARTS & ACCESSORIES
FUEL INJECTION
THROTTLE BODIES
FUEL PUMPS
INTAKE MANIFOLDS
CYLINDER HEADS
SYSTEMAX
ENGINE DRESS-UP
MERCHANDISING
TECHNICAL INFORMATION
INDEX

EFI Fuel Rails - Universal

These Holley CNC machined aluminum fuel rails are designed for high flow, custom applications. Holley EFI fuel rails are the perfect complement to the Holley lines of high flow in-tank fuel pumps, performance fuel injectors, intake manifolds, adjustable fuel pressure regulators and high flow billet throttle bodies for your custom installation. Universal fuel rails require machining to fit your injector mounting situation.



- Universal 12" length **Part # 534-78**
- Universal 18" length **Part # 534-79**
- Universal 36" length **Part # 534-80**

NOTE: Fuel rails are sold individually.

Performance Fuel Injector Kits

These injector kits will enable you to upgrade the fuel delivery system of your engine. This is a definite necessity when you begin modifying a stock engine with such items as a performance fuel pump and camshaft or modifying the stock cylinder heads or upgrading to new performance cylinder heads, adding headers, high-flow throttle bodies, etc.



The fuel injectors here are all top-fed, Bosch-style with various flow ratings as shown below. The chart also equates the injector fuel flow potential to a engine horsepower rating.

Part #	Application/Horsepower*	Qty.	Injector Flow (lbs/hr)	Impedance
522-1904	Universal	4	19	High
522-1906	Universal	6	19	High
522-1908	Universal; 300 HP maximum	8	19	High
522-2401	Universal	1	24	High
522-2408	Universal; 385 HP maximum	8	24	High
522-3001	Universal	1	30	High
522-3008	Universal; 480 HP maximum	8	30	High
522-3601	Universal	1	36	High
522-3608	Universal; 575 HP maximum	8	36	High
522-4201	Universal	1	42	High
522-4208	Universal; 670 HP maximum	8	42	High
522-5001	Universal	1	50	High
522-5008	Universal; 800 HP maximum	8	50	High
522-6501	Universal	1	65	Low
522-6508	Universal; 1050 HP maximum	8	65	Low
522-7501	Universal	1	75	Low
522-7508	Universal; 1200 HP maximum	8	75	Low
522-9501	Universal	1	95	Low
522-9508	Universal; 1520 HP maximum	8	95	Low

Note: To convert lbs. per hour fuel flow to cc per minute fuel flow, multiply the lbs. per hour number by 10.5092. For example, 42 lbs. per hour is equal to 441.3 cc per minute fuel flow.

(*) A BSFC of 0.45 and 90% duty cycle is used for the maximum horsepower recommendation.

THROTTLE BODIES

THROTTLE BODIES 120-123

Direct Replacement Performance Truck TBIs	120
Airfoil Kit.....	121
Universal 4-bbl Billet Throttle Bodies.....	121
High-Flow EFI Throttle Bodies	122-123

HOW TO CHOOSE A CARB
STREET CARBURETORS
SUPERCHARGER CARBURETORS
RACE CARBURETORS
MARINE CARBURETORS
CARB SERVICE PARTS & ACCESSORIES
FUEL INJECTION
THROTTLE BODIES
FUEL PUMPS
INTAKE MANIFOLDS
CYLINDER HEADS
SYSTEMS
ENGINE DRESS-UP
MERCHANDISING
TECHNICAL INFORMATION
INDEX

Direct Replacement Performance TBIs

Holley designed these throttle bodies with all relevant emission provisions and hook-ups for a true 50-State legal installation. They are engineered for a "bolt-on" installation on stock factory manifolds for the applications cataloged. The one barrel throttle bodies have been assigned California Air Resources Board (C.A.R.B.) Executive Order (E.O.) number D-115-4. The two barrel throttle replacement bodies are considered to be the functional equivalent of the original equipment throttle body and, as such, are considered to be 50-State legal. Therefore, the C.A.R.B. E.O. number is not required.

Features

- Direct replacement for O.E. units
- Bolt-on performance replacement for O.E. GM TBI units
- Can increase horsepower up to 25%
- Compatible only with stock O.E. GM electronics
- Provides increased torque and horsepower

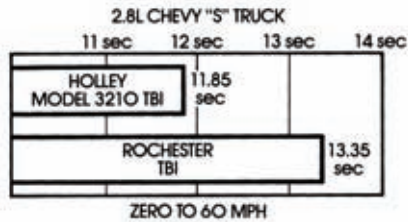

2.8L Zero-60 MPH

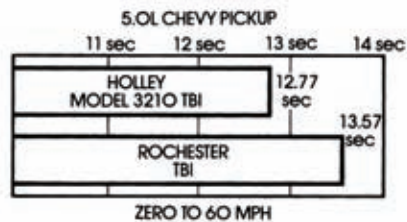

5.0L Zero-60 MPH

Make	Model	Year	Engine	# Bbl	CFM	P/N
Chevy/GMC	S/T Series Truck	1985 1/2-89	2.8L 6 cyl.	2	400	502-3
Chevy/GMC	S/T Series Truck	1988-91	4.3L 6 cyl.	2	670	502-7
Chevy/GMC	Full size Truck	1986-89	4.3L 6 cyl.	2	670	502-4
Chevy/GMC	Full size Truck	1987-89	5.0L 8 cyl.	2	670	502-5
Chevy/GMC	Full size Truck	1987-89	5.7L 8 cyl.	2	670	502-6
Chevy/GMC	Full size Truck	1990-95	5.7L 8 cyl.	2	670	502-9

* 95 w/o throttle cam

Airfoil Kit



120-140

GM Throttle Body Airfoil Kit Part # 120-140

1985-92 Camaro/Firebird w/ 5.7L TPI
 1992-98 Camaro/Firebird w/ 5.7L LT1

Talk about a smooth operator! This Holley airfoil kit easily adapts to the stock GM throttle body on Chevrolet 5.7L TPI and LT1 engines used on Camaros and Firebirds. It acts to smooth out and minimize the turbulence of the incoming flow of air into the throttle body. **The September, 2002 edition of GM HIGH-TECH PERFORMANCE magazine reported a 5.8 horsepower increase after installing this Holley airfoil kit on a stock 1994 Camaro Z28 LT1, called "The Grape Of Wrath".**

Installation is easy; simply snap it into place in the mouth of the throttle body and it's ready to work. Made from space age elastomer, the Holley airfoil will perform effectively and unobtrusively for years.

Universal 4-bbl Billet Throttle Bodies



112-538

1000 CFM (square flange) with IAC **Part # 9900-171**

2000 CFM (DOMINATOR flange) **Part # 112-538**

If you're thinking of building either a high performance or race multi-point fuel injection system for your engine, look no further than Holley for the throttle body.

Holley offers a line of universal throttle bodies that range in sizes from 1000 CFM to 2000 CFM and are available with standard square bore or DOMINATOR flanges. These billet beauties will provide all the air your motor can ingest. Sporting premium design features that enhance their ruggedness and durability, Holley performance throttle bodies are built to take the most severe usage. They'll look great as well - sitting on top of your street rod or street/strip engine. They have the looks to go with the brawn!

Features

- True cut CNC billet construction
- Progressive linkage system for more precise throttle control and better driveability.
- Idle air control (IAC) system incorporates over-sized passages to accommodate larger engines to further enhance idle quality and control.
- Throttle shafts are offset with respect to the throttle plates so engine vacuum will assist throttle plate closure.
- Provision for installing Holley P/N 20-113, TH-700R4 over-drive transmission kick-down cable bracket.
- Special machined radii on top and bottom of throttle body promotes maximum airflow and minimizes air turbulence.
- Three manifold vacuum ports are available including one for PCV.
- 1000 CFM throttle body utilizes a standard square bore while the 2000 CFM throttle body is designed with a Dominator Flange
- 1000 CFM utilizes 1.75" bores while the 2000 CFM utilizes 2.25" throttle bores.

HOW TO CHOOSE A CARB
 STREET CARBURETORS
 SUPERCHARGER CARBURETORS
 RACE CARBURETORS
 MARINE CARBURETORS
 CARB SERVICE PARTS & ACCESSORIES
 FUEL INJECTION
THROTTLE BODIES
 FUEL PUMPS
 INTAKE MANIFOLDS
 CYLINDER HEADS
 SYSTEMAX
 ENGINE DRESS-UP
 MERCHANDISING
 TECHNICAL INFORMATION
 INDEX

Holley High-Flow EFI Throttle Bodies

Does your engine seem like it's out of breath? You can increase engine breathing with a Holley high-air-flow throttle body! Fully CNC machined from 6061 billet aluminum, these new Holley throttle bodies are designed to use the stock TPS and IAC to simplify installation. They are bright dipped clear anodized for long lasting good looks and corrosion protection. They also include all the necessary vacuum ports and linkage to facilitate installation. Don't get left in the dust. New Holley high-flow throttle bodies are the ticket to ride. **NOTE: Some manifold machining may be required to correctly port-match the throttle body to the intake.**



112-504 - GM LT-1



112-512 - Ford 5.0L



112-548



112-557 - Dodge Truck 5.2/5.9L



NEW 112-573 - Ford 4.6L



NEW 112-574 - GM LS2

Application	Engine	Year	Size	Color	Part #
Acura Integra	1.8L V-Tec	1992-95	1 x 62mm	Clear Coat	112-548
Acura Integra	1.8L V-Tec	1996-00	1 x 62mm	Clear Coat	112-549
Acura Integra	1.8L V-Tec	1992-95	1 x 68mm	Clear Coat	112-532*
Acura Integra	1.8L V-Tec	1996-00	1 x 68mm	Clear Coat	112-554*
Buick GN/Race	3.8L w/ IAC	1984-87	1 x 95mm	Clear Coat	112-512
Buick GN/Race	3.8L w/o IAC	1984-87	1 x 95 mm	Clear Coat	112-513
Buick GN/Race	3.8L w/o IAC	1986-93	1 x 105mm	Clear Coat	112-535
Chevrolet Camaro	5.7L TPI	1985-88	2 x 52mm	Clear Coat	112-502
Chevrolet Camaro	5.7L TPI	1985-88	2 x 58mm	Clear Coat	112-503
Chevrolet Camaro	5.7L TPI	1989-92	2 x 52mm	Clear Coat	112-506
Chevrolet Camaro	5.7L TPI	1989-92	2 x 58mm	Clear Coat	112-507
Chevrolet Camaro	5.7L LT1	1993	2 x 52mm	Clear Coat	112-504
Chevrolet Camaro	5.7L LT1	1993	2 x 58mm	Clear Coat	112-505
Chevrolet Camaro	5.7L LT1	1994-97	2 x 52mm	Clear Coat	112-508
Chevrolet Camaro	5.7L LT1	1994-97	2 x 58mm	Clear Coat	112-509
Chevrolet Camaro	NEW LS w/ LS2, Fast™ or Weiland Street Warrior Intake (cable driven)		1 x 80mm	Clear Coat	112-574
Chevrolet Camaro	NEW LS w/ LS2, Fast™ or Weiland Street Warrior Intake (cable driven)		1 x 90mm	Clear Coat	112-576
Chevrolet Corvette	NEW LS w/ LS2, Fast™ or Weiland Street Warrior Intake (cable driven)		1 x 80mm	Clear Coat	112-574
Chevrolet Corvette	NEW LS w/ LS2, Fast™ or Weiland Street Warrior Intake (cable driven)		1 x 90mm	Clear Coat	112-576
Chevrolet Corvette	5.7L LT1	1992-93	2 x 52mm	Clear Coat	112-504
Chevrolet Corvette	5.7L LT1	1992-93	2 x 58mm	Clear Coat	112-505
Dodge Truck (all)	3.9L V6	1994-99	2 x 52mm	Clear Coat	112-556
Dodge Truck (all)	5.2/5.9L	1994-95	2 x 52mm	Clear Coat	112-555
Dodge Truck (all)	5.2/5.9L	1996-01	2 x 52mm	Clear Coat	112-557

HOW TO CHOOSE A CARB
STREET CARBURETORS
SUPERCHARGER CARBURETORS
RACE CARBURETORS
MARINE CARBURETORS
CARB SERVICE PARTS & ACCESSORIES
FUEL INJECTION
THROTTLE BODIES
FUEL PUMPS
INTAKE MANIFOLDS
CYLINDER HEADS
SYSTEMAX
ENGINE DRESS-UP
MERCHANDISING
TECHNICAL INFORMATION
INDEX

Application	Engine	Year	Size	Color	Part #
Ford Mustang	5.0L EFI	1986-93	1 x 70mm	Clear Coat	112-500
Ford Mustang	5.0L EFI	1986-93	1 x 75mm	Clear Coat	112-501
Ford Mustang	5.0L EFI	1986-93	1 x 80mm	Clear Coat	112-510
Ford Mustang	5.0L EFI w/ IAC	1986-93	1 x 95mm	Clear Coat	112-512'
Ford Mustang	5.0L EFI w/o IAC	1986-93	1 x 95mm	Clear Coat	112-513'
Ford Mustang	5.0L EFI w/o IAC	1986-93	1 x 105mm	Clear Coat	112-535'
Ford Mustang	2V 4.6L EFI	1996-04	1 x 70mm	Clear Coat	112-573
Ford Mustang	2V 4.6L EFI	1996-04	1 x 75mm	Clear Coat	112-575
Honda Civic	1.6L VTEC	1992-95	1 x 62mm	Clear Coat	112-546
Honda Civic	1.6L VTEC	1992-95	1 x 68mm	Clear Coat	112-511*
Honda Civic	1.6L VTEC	1996-00	1 x 62mm	Clear Coat	112-547
Honda Civic	1.6L VTEC	1996-00	1 x 68mm	Clear Coat	112-540*
Jeep Grand Cherokee	5.9L	1997-98	2 x 52mm	Clear Coat	112-555
Pontiac Firebird	5.7L TPI	1985-88	2 x 52mm	Clear Coat	112-502
Pontiac Firebird	5.7L TPI	1985-88	2 x 58mm	Clear Coat	112-503
Pontiac Firebird	5.7L TPI	1989-92	2 x 52mm	Clear Coat	112-506
Pontiac Firebird	5.7L TPI	1989-92	2 x 58mm	Clear Coat	112-507
Pontiac Firebird	5.7L LT1	1993	2 x 52mm	Clear Coat	112-504
Pontiac Firebird	5.7L LT1	1993	2 x 58mm	Clear Coat	112-505
Pontiac Firebird	5.7L LT1	1994-97	2 x 52mm	Clear Coat	112-508
Pontiac Firebird	5.7L LT1	1994-97	2 x 58mm	Clear Coat	112-509
Pontiac Firebird	LS w/ LS2, Fast™ or Weiand Street Warrior Intake		1 x 80mm	Clear Coat	112-574
Pontiac Firebird	LS w/ LS2, Fast™ or Weiand Street Warrior Intake		1 x 90mm	Clear Coat	112-576
Universal**			1 x 105mm	Clear Coat	112-535'

* Intake manifold modifications may be necessary on stock manifolds. † Uses Ford Mustang style linkage
 ** 5.0L Ford bolt pattern

Holley LS2 Throttle Bodies

Got an LS engine retrofitted with an LS2, FAST™ or Weiand Street Warrior™ intake manifold? Need more air? How about an 80mm or 90mm billet aluminum throttle body? Here they are - the finest LS throttle bodies on the market! They are throttle cable actuated and feature a full roller bearing supported throttle shaft to prevent sticking and improve longevity. Their contoured throttle bore design provides smooth and predictable performance from idle to WOT. They also feature factory style stamped steel throttle linkage and an included throttle cable bracket for a precise fit. They feature a clear anodized finish for long lasting good looks!



FAST™ is a trademark of the Comp Performance Group.

Application	Engine	Size	Color	Part #
Universal	LS w/ LS2, Fast™ or Weiand Street Warrior Intake	1 x 80mm	Clear Coat	112-574
Universal	LS w/ LS2, Fast™ or Weiand Street Warrior Intake	1 x 90mm	Clear Coat	112-576

Throttle Body Service Parts

- Gasket, GM TPI & LT1 Throttle Body
- Plate, IAC Block-off Part # 108-116
- Ford throttle bodies. Part # 112-560

- Spacers, EGR, Ford Throttle Bodies
- 1-bbl throttle body (1 x 70mm) Clear Coat. Part # 112-550

- Throttle Plate Service Kits
- 2000 CFM throttle body Part # 9925-103
- 1 x 65mm Ford throttle body Part # 26-134
- 1 x 75mm Ford throttle body (stainless steel plate) Part # 26-131
- 1 x 80mm Ford throttle body (stainless steel plate) Part # 26-132



or See page 223 for symbol explanation.

HOW TO CHOOSE A CARB
 STREET CARBURETORS
 SUPERCHARGER CARBURETORS
 RACE CARBURETORS
 MARINE CARBURETORS
 CARB SERVICE PARTS & ACCESSORIES
 FUEL INJECTION
 THROTTLE BODIES
 FUEL PUMPS
 INTAKE MANIFOLDS
 CYLINDER HEADS
 SYSTEMAX
 ENGINE DRESS-UP
 MERCHANDISING
 TECHNICAL INFORMATION
 INDEX

43 CARS

It's the same scene at every NASCAR® race, NHRA®, IHRA®, NMCA™, NMRA™, ARCA®, IMCA® and hundreds of others each weekend across the country - Holley carbs dominating the track. In fact, Holley carbs are the winningest in racing history! Don't settle for weak performance gains or imitations.

**THERE'S ONLY ONE
HOLLEY - THE FUEL
SYSTEMS LEADER
FOR OVER
100 YEARS.**

43 HOLLEY carbs

STREET TO RACE - Holley Delivers Performance!

Street Avenger™ Carbs

- Street-ready carbs loaded with "No Trouble" features for killer bolt-on performance
- Available in 570, 670, 770 & 870 CFM

4150 Double Pumpers®

- Mechanical secondaries offer awesome tire-turning performance for lightweight vehicles, manual transmission vehicles and/or cars with low gearing
- Available in 600, 650, 700, 750, 800 & 850 CFM

4150 Street HP™ Carbs

- Street/Strip performance with budget-minded pricing
- Available in 650 (mechanical secondaries) & 750 CFM (mechanical or vacuum secondaries)

4150 HP™ & 4500 HP Dominator® Carbs

- Race-ready out-of-the-box with contoured venturii, screw in air bleeds, stainless steel throttle plates and more
- 4150 HP (standard flange) available in 390, 600, 650, 750, 830, 950 & 1000 CFM
- 4500 HP Dominator® available in 750, 1050, 1150 & 1250 CFM
- Ultra HPs & Ultra Dominators® feature adjustable billet metering blocks

Tech Line: 270-781-9741
www.holley.com

For nearest dealer,
call 1-800-HOLLEY-1
then punch ext. 1074

NASCAR® and NASCAR Performance® are registered trademarks of the National Association for Stock Car Auto Racing, Inc.
NHRA is a registered trademark of the National Hot Rod Association
All race association abbreviations are registered trademarks of their respective owners



**Holley Carbs Power
Every NASCAR® SPRINT®
Cup Series team!**



FUEL PUMPS

FUEL PUMPS 126 - 140

Mechanical Fuel Pumps.....	126-127
Electric Fuel Pumps.....	128-132
Marine Mechanical Fuel Pumps.....	133
Marine Electric Fuel Pumps.....	134
Regulators & Accessories.....	135-137
VoluMAX® Filters & Accessories.....	138-140
Electric Fuel Pump Service Kits.....	139-140

Mechanical Fuel Pumps



Application	80 GPH	110 GPH	130+ GPH	170+ GPH	170 GPH Billet	200 GPH Billet	225 GPH Billet (Alcohol)
Chevy S/B V-8	12-834 (B) 2	12-327-11 (B) 2	12-327-13 (B) 2	12-327-20 (B) 3	12-327-25 (B) 3	12-327-30 (B) 3	12-327-35 (B) 3
Chevy B/B V-8	12-835 (B) 2	12-454-11 (B) 2	12-454-13 (B) 2	12-454-20 (B) 3	12-454-25 (B) 3	12-454-30 (B) 3	12-454-35 (B) 3
Chevy B/B Marine						12-454-40 (B) 3	
Chrysler S/B V-8	12-838 (B) 2	12-360-11 (B) 2 *					
Chrysler B/B V-8		12-440-11 (B) 2 *					
Ford 289/302/351W	12-833 (B) 2	12-289-11 (B) 2	12-289-13 (B) 2	12-289-20 (B) 3	12-289-25 (B) 3	12-289-30 (B) 3	12-289-35 (B) 3
Ford 351C/351M	12-854 (B) 2						
Ford 390, 427, 428 FE	12-832 (B) 2	12-390-11 (B) 2 *					
Ford 429/460 V-8	12-860 (B) 2	12-460-11 (B) 2	12-460-13 (B) 2				
Oldsmobile All V-8	12-836 (B) 2						
Pontiac All V-8	12-837 (B) 2	12-389-11 (B) 2 *					

*Inlet & outlet tapped for 1/4" NPT

80 GPH Fuel Pump



Features

- Street Performance
- Flows 80 GPH (free flow)
- Shutoff pressure pre-set at 7-1/2 PSI
- Heavy duty construction for continuous high RPM operation
- Fuel body casting can be rotated to accommodate various plumbing situations
- Fuel pressure regulator is not required
- Inlet & outlet tapped for 1/4" NPT

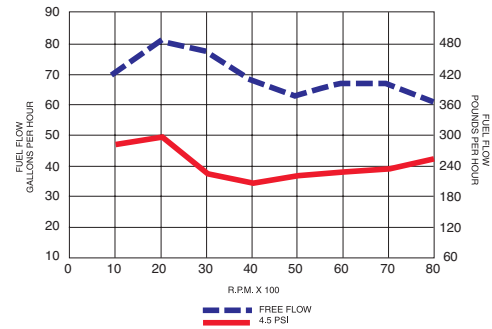

110 GPH Fuel Pump



Features

- High output fuel flow
- Flows 110 GPH (free flow)
- Shutoff pressure pre-set from 6 1/2 - 8 PSI
- Heavy duty construction for continuous high RPM operation
- Fuel body casting can be rotated to accommodate various plumbing situations
- Fuel pressure regulator is not required
- Inlet & outlet tapped for 3/8" NPT, except as noted

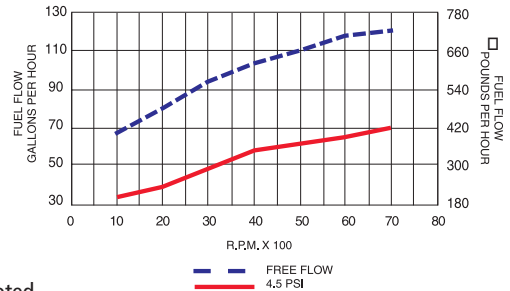

130+ GPH FUEL PUMP



Features

- High output fuel flow
- Flows 130+ GPH (free flow)
- Shutoff pressure pre-set from 7 1/2 - 9 PSI
- Heavy duty construction for continuous high RPM operation
- Redesigned high flow valves always ensure adequate fuel delivery
- Inlet & outlet tapped for 3/8" NPT
- Fuel body casting can be rotated to accommodate various plumbing situations
- Fuel pressure regulator is required. Recommend Holley P/N 12-704

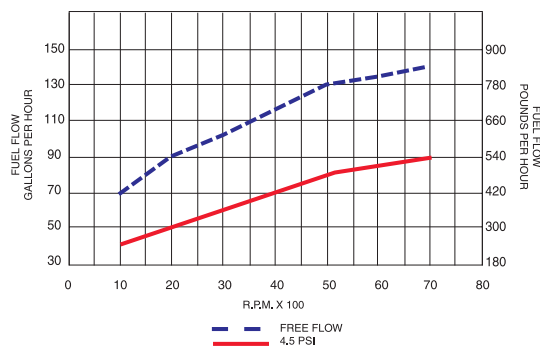

170+ GPH Fuel Pump

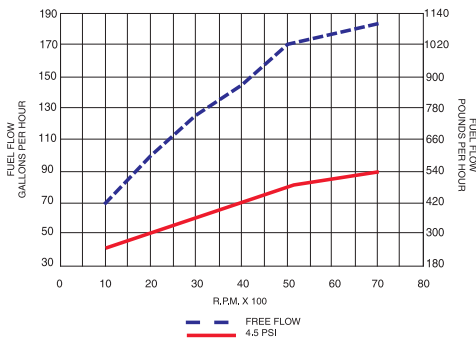

Features

- High output fuel flow
- Flows 170+ GPH (free flow)
- Shutoff pressure pre-set at 8 PSI
- Heavy duty construction for continuous high RPM operation
- Redesigned high flow valves always ensure adequate fuel delivery
- AN -10 inlet and -8 outlet ports
- Fuel body casting can be rotated to accommodate various plumbing situations
- Fuel pressure regulator is required. Recommend Holley P/N 12-704



170 GPH HP Series 3 Valve Fuel Pump

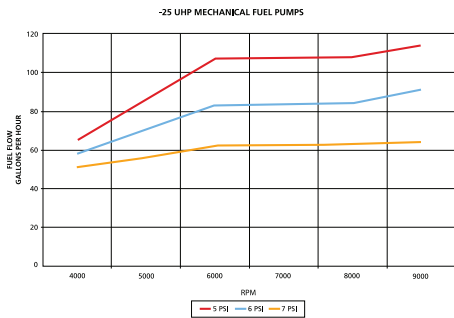

Features

- HP Series flow 170 GPH free flow
- Made from 6061-T6 billet aluminum for durability & good looks
- CNC billet finish for good looks
- -8 inlet & outlets (non-changeable)
- Pre-set idle fuel pressure of 7.5 PSI
- No fuel pressure regulator required
- Comes standard with -8 AN inlet & outlet fittings already installed
- Bases are independently rotatable from the top for ease of installation
- Inlet & outlet tapped for 5/8-18 straight
- Fittings can not be removed



200 & 225 GPH Ultra HP Series 5 Valve Fuel Pump

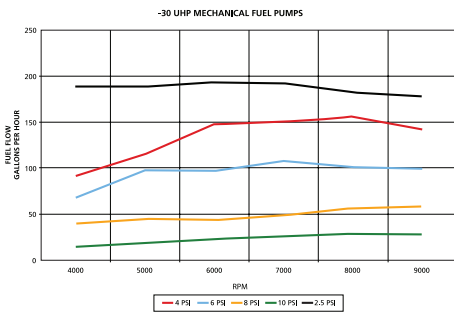

Features

- Ultra HP Series -30 flow 200 GPH free flow (gasoline), -35 flow 225 GPH (alcohol)
- Made from 6061-T6 billet aluminum for durability & good looks
- Hard coat anodized for corrosion resistance
- -10 AN inlet and -8 AN outlet fittings included
- -30 and -40 fuel pumps have a preset shutoff pressure of 10-11 PSI while -35 pumps have a preset shutoff pressure of 15.5-17 PSI
- Require fuel pressure regulator such as Holley p/n 12-704
- Bases are independently rotatable from the top for ease of installation
- All Ultra HP fuel pumps are rebuildable
- Intended for hard core strip use or are perfect for use in circle track classes
- Inlet & outlet tapped for 3/4-16 straight O-ring
- Inlet & outlet tapped for 1/2" NPT for BBC Marine

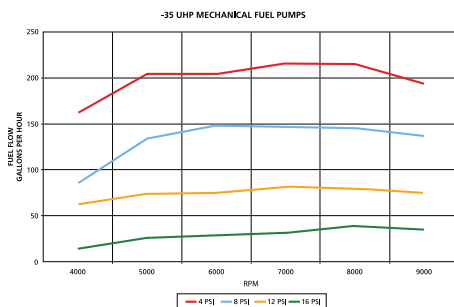

Electric Fuel Pumps - Carbureted

Part #	Free Flow Rate (GPH)	GPH Flow at Rated PSI	Application	Use With Alcohol Methanol	Holley Recommendations for Peak Performance					
					MAX PSI	Max HP*	Inlet Line Size	Outlet Line Size	Fuel Pressure Regulator	Relay Kit
12-801-1	97	71 @ 4 PSI	Street/Strip	No	7	425*	3/8"	3/8"	N/A (1)	12-753
12-802-1	110	95 @ 7 PSI	Street/Strip	No	14	550*	3/8" or -6AN	3/8" or -6AN	12-803 (included)	12-753
12-812-1	110	95 @ 7 PSI	Street/Strip	No	14	550*	3/8" or -6AN	3/8" or -6AN	12-803 or 12-803BP(2)	12-753
12-815-1	140	120 @ 9 PSI	Street/Strip	Yes	14	750*	1/2" or -8AN	3/8" or -6AN	12-704 (3) or 12-707 (4)	12-753
12-125	125	110 @ 7 PSI	Street/Strip	Yes	7	750*	3/8" or -6AN	3/8" or -6AN	12-803(1) or 12-804(1)	12-753
12-150	150	140 @ 7 PSI	Street/Strip	Yes	16	900*	1/2" or -8AN	3/8" or -6AN	12-803 (5) (included) or 12-803BP (2) or 12-707 (4)	12-753

- Footnotes:**
- 1 Applications requiring 1-4 psi should use regulator p/n 12-804, applications requiring 4-1/2 to 9 psi should use regulator 12-803 or 12-704
 - 2 12-803BP regulator is a bypass regulator and requires a minimum of a 3/8" or -6 return line back to tank
 - 3 Single 4bbl Application
 - 4 Dual 4bbl Application
 - 5 Use 12-803 if horsepower is below 750, otherwise use regulator p/n 12-704

*Horsepower recommendations are estimates based on gasoline.

Individual systems will vary depending on fuel system design, regulator type, fuel cell location and launch G's.

97 GPH - Red® Electric Fuel Pump Part # 12-801-1^(B)

See electric fuel pump chart above for additional info



Features

- New tumble polished billet look
- Improved design for street/strip applications
- Distinctive "RED" logo
- Flows 97 GPH (free flow)
- Flows 71 GPH at 4 PSI
- Maximum pressure is 7 PSI
- Regulator is not required
- Motor draws only 2 Amps current
- 7 1/2 Amp fuse recommended
- Provides constant fuel flow with no pulsation
- Has externally accessible pressure relief valve (max 7 PSI)
- Rotor/Vane pump design is more tolerant of contaminated fuels
- New lower housing casting for enhanced fuel flow and quieter operation
- Weighs only 2.88 lbs.
- Includes mounting bracket
- Repair kits are readily available
- NOT compatible with alcohol or methanol fuels
- Use of safety shut-off switch, P/N 12-810, strongly recommended
- Not designed or recommended for use with fuel injection systems
- 3/8 NPT inlet/outlet

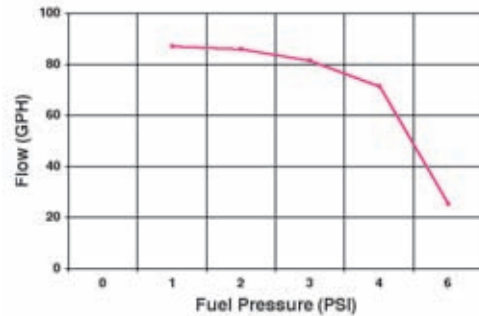

110 GPH - Blue® Electric Fuel Pump Part # 12-802-1^(B) 2

See electric fuel pump chart on page 128 for additional info

Part # 12-812-1^(B) 2
(without regulator)

Features

- New tumble polished billet look
- New lower housing casting for enhanced fuel flow
- Improved design for street/strip applications
- Distinctive "BLUE" logo
- Flows 110 GPH (free flow)
- Flows 88 GPH at 9 PSI
- Maximum pressure is 14 PSI
- Includes P/N 12-803 fuel pressure regulator
- Motor draws only 3 Amps current
- 7 1/2 Amp fuse recommended
- Provides constant fuel flow with no pulsation
- Has externally accessible pressure relief valve (max 14 PSI)
- Rotor/Vane pump design is more tolerant of contaminated fuels
- Weighs only 3 lbs.
- Includes mounting bracket
- Repair kits are readily available
- NOT compatible with alcohol or methanol fuels
- Use of safety shut-off switch, P/N 12-810, strongly recommended
- Not designed or recommended for use with fuel injection systems
- 3/8 NPT inlet/outlet

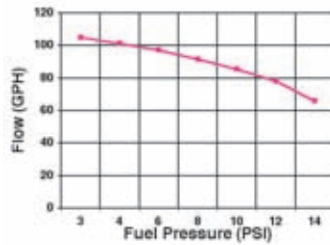

140 GPH - Black® Electric Fuel Pump Part # 12-815-1^(B) 2

See electric fuel pump chart on page 128 for additional info

Features

- New tumble polished billet look
- New lower housing casting for enhanced fuel flow
- Improved design for street/strip applications
- Distinctive "BLACK" logo
- Compatible with alcohol or methanol fuels
- Flows 140 GPH (free flow)
- Flows 120 GPH at 9 PSI
- Maximum pressure is 14 PSI
- 3/8" NPT inlet and outlet ports
- Fuel pressure regulator is required. Recommend P/N 12-704 for gasoline; P/N 12-707 for alcohol
- Motor draws only 4 Amps current
- 7 1/2 Amp fuse recommended
- Provides constant fuel flow with no pulsation
- Has externally accessible pressure relief valve (max 14 PSI)
- Rotor/Vane pump design is more tolerant of contaminated fuels
- Weighs only 3 lbs.
- Includes mounting bracket
- Repair kits are readily available
- Use of safety shut-off switch, P/N 12-810, strongly recommended
- Not designed or recommended for use with fuel injection systems
- 3/8 NPT inlet/outlet

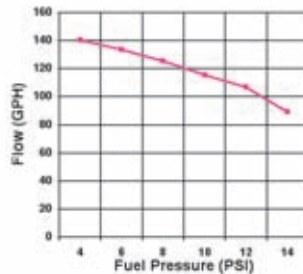

125 GPH - Billet Electric Fuel Pump Part # 12-125^(B) 2

150 GPH - Billet Electric Fuel Pump Part # 12-150^(B) 2



See electric fuel pump chart on page 128 for additional info

Ultra quiet - Powerful enough for race day. Quiet enough for everyday!

Looking for a fuel pump that is quiet, stylish, powerful and dependable? Look at the new Holley HP 125 and HP 150 series fuel pumps. The exclusive gerotor gearset quietly and efficiently pumps the fuel without the noise of traditional vane pumps. The chrome motor and trick powder coated bracket match the mil-spec hard anodized base for unmatched beauty and durability. While these pumps have the capability to feed stout race engines, they are equally at home on the street due to their design and construction techniques.

Features

- Gerotor design for quiet, smooth operation and durability
- Compatible with gas alcohol or methanol fuels
- Black Mil-spec nickel Teflon hard anodized billet base
- Show quality chrome 12V motor
- Profiled, black powdercoated mounting bracket
- Laser engraved Holley logo and inlet/outlet designations
- 3/8" NPT inlet and outlet fittings
- Regulator included (12-150 ONLY)
- Both pumps equally at home on the street as well as at the races.
- Overall height of 6-1/4"



Holley HP125 Fuel Pump Performance Data

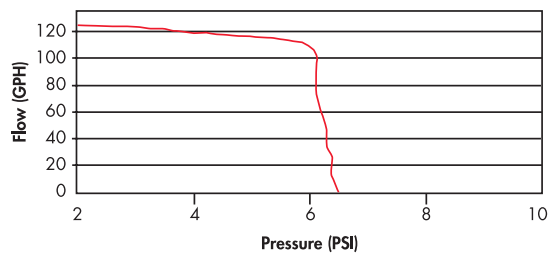

Holley HP150 Fuel Pump Performance Data

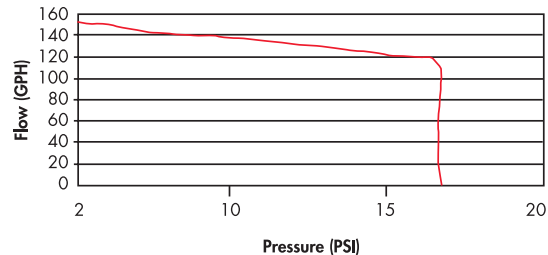

Part #	Horsepower	Description
12-125	Stock to 750	125 GPH (110 GPH @ 7 psi) and internally regulated to 7 psi
12-150	Stock to 900	150 GPH (140 GPH @ 7 psi) and internally regulated at 16 psi - includes 4 1/2-9 psi regulator # 12-803 for applications up to 750 HP. Use 12-704 (available separate) for applications above 750 HP

Electric In-Tank Fuel Pumps

The Holley line of high output in-tank electric fuel pumps is available in flow ratings of 190 and 255 liters of fuel per hour. A 155 liter per hour Mustang pump is available along with 255 liter-per-hour-rated pumps for "forced induction" applications. These particular pumps flow significantly more fuel at higher pressure. For example, at 80 PSI the standard 255 lph pump will flow around 132 liters (35 gallons) per hour. At that same 80 PSI the equivalent forced induction fuel pump will flow over 210 liters (50 gallons) per hour. The chart here aptly illustrates the capabilities of the Holley in-tank electric fuel pumps.

Holley in-tank electric fuel pumps utilize a proven gerotor design. The outside dimensions, however, are compact enough to fit existing hanger assemblies, without modification. Coverage includes most popular Ford, General Motors, Chrysler and Import applications.

These are complete fuel pump kits and include all drop parts, accessories and installation instructions. Also included is an inlet filter that meets or exceeds original equipment specifications and provides improved filtration and durability.

LITERS	GALLONS	LBS. OF FUEL	HORSEPOWER
155	41	246	491
190	50	301	600
255	67	404	800



Application	Year	Engine	155 lph	190 lph	255 lph	255 forced induction
Acura Integra	1998-94	1.8L		12-917	12-906	12-916
Buick Regal/ Grand National	1987-84	3.8L turbo V6		12-900		12-914
Chevrolet Camaro	1992-85	5.0L TPI				12-914
	1992-85	5.7L TPI				12-914
Dodge Daytona, Lancer, Shadow, Spirit	1990-85	2.2L turbo		12-905	12-904	
	1990-89	2.5L turbo		12-905	12-904	
	1990-89	3.0L V6		12-905	12-904	
Dodge Neon	1999-95	2.0L				12-921
Eagle Talon	1998-95	2.0L turbo			12-907	12-918
	1994-90	2.0L AWD/turbo			12-911	12-919
Ford Mustang (exc. Cobra)	1997-96	4.6L MPI	12-912	12-901	12-902	12-915
	1995-85	5.0L EFI	12-912	12-901	12-902	12-915
Honda Civic	1998-92	1.5L		12-917	12-906	12-916
	1998-92	1.5L VTEC		12-917	12-906	12-916
	1998-92	1.6L VTEC		12-917	12-906	12-916
	1992-89	1.3L Rotary/turbo			12-909	
	1992-89	1.3L Rotary			12-909	
Mitsubishi Eclipse	1998-95	2.0L turbo			12-907	12-918
	1994-90	2.0L AWD/turbo			12-907	12-918
Plymouth Acclaim, Caravelle, Reliant, Sundance	1990-85	2.2L turbo			12-904	
	1990-89	2.5L turbo			12-904	
	1990-89	3.0L V6			12-904	
Plymouth Neon	1999-95	2.0L				12-921
Pontiac Firebird & Fiero	1992-85	5.0L TPI				12-914
	1992-85	5.7L TPI				12-914
	1986-85	2.8L EFI				12-914
Toyota Pickup(2WD)	1995-92	2.4L			12-910	
Toyota Supra	1994-86	3.0L				12-913

Electric In-Line Fuel Pumps Part # 12-920

480 PPH @ 15 PSI

Part # 12-927

258 PPH @ 15 PSI

These Holley universal, in-line fuel pumps are intended for fuel injection systems. They are designed to work in-line, not inside the tank, so installation is a snap. They're all rated for continuous duty service and have been tested up to 2500 hours. The high output versions are great for serious performance work. These pumps should be mounted below the fuel level of the tank for a good gravity feed on the inlet side.

Features

- OE-proven design
- Lightweight, compact design
- 3/8" barbed fittings included
- Rubber isolator, mounting clamps and electrical hardware is included



OPTIONAL PARTS & KITS

P/N	DESCRIPTION
26-160	-6 AN fittings (pair)
26-180	-8 AN fittings (pair)

P/N	Throttle Body Injection	Multi-Point Injection	Forced Induction	Flow @ 15 psi (GPH)*	Flow @ 15 psi (PPH)*	Current draw @ 15 psi	Flow @ 45 psi (GPH)*	Flow @ 45 psi (PPH)*	Current draw @ 45 psi	Approximate Maximum Horsepower		
										Throttle Body Injection	Multi-Point Naturally Aspirated	Multi-Point Forced Induction
12-920	Y	Y	Y	80	480	5 Amps	67	402	8 Amps	800	700	600
12-927	Y	N	N	43	258	3.5 Amps	N/A	N/A	N/A	400	N/A	N/A

(* Flow figures at 13.5 Volts.

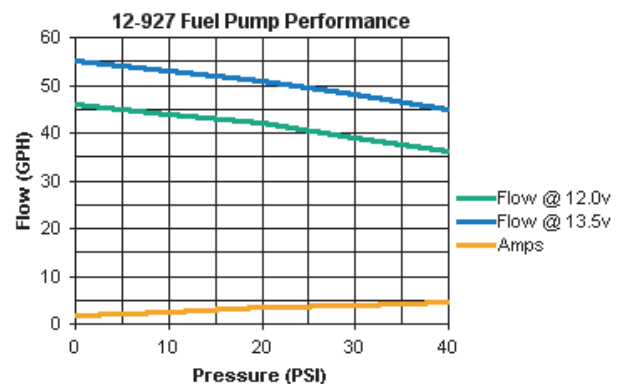
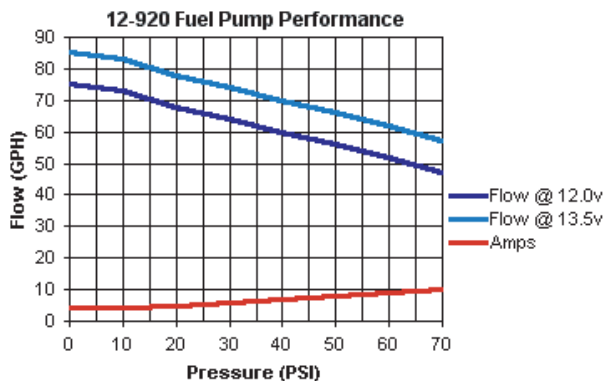

Marine Mechanical Fuel Pumps HOLLEY DESIGNED & BUILT!

The Holley line of high output mechanical fuel pumps with their new aluminum housings save weight and all components have been designed for extreme reliability and safety. Performance is there to the MAX. Available in both 110 GPH and 130+ GPH versions, either pump is your assurance that your Chevy or Ford engine will never starve for fuel. One look at the features and performance charts, should convince you. A fuel/fume tube is part of the marine design to provide a safe fuel exit in the unlikely event of a diaphragm rupture.

Application	Engine	110 GPH	130+ GPH	200 GPH Billet
Chevrolet	Small Block V-8	712-327-11		
Chevrolet	Big Block V-8	712-454-11	712-454-13	12-454-40



110 GPH Fuel Pump

Features

- High output fuel flow
- Flows 110 GPH (free flow)
- Shutoff pressure pre-set from 6 1/2 - 8 PSI
- Heavy duty construction for continuous high RPM operation
- Inlet & outlet tapped for 3/8" NPT
- Fuel body casting can be rotated to accommodate various plumbing situations
- Fuel pressure regulator is not required
- Fuel/vapor tube

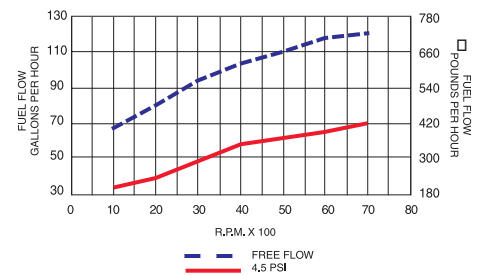

130+ GPH Fuel Pump

Features

- High output fuel flow
- Flows 130+ GPH (free flow)
- Shutoff pressure pre-set from 7 1/2 - 9 PSI
- Heavy duty construction for continuous high RPM operation
- Redesigned high flow valves always ensure adequate fuel delivery
- Inlet & outlet tapped for 3/8" NPT
- Fuel body casting can be rotated to accommodate various plumbing situations
- Fuel pressure regulator is required. Recommend Holley P/N 12-704
- Fuel/vapor tube

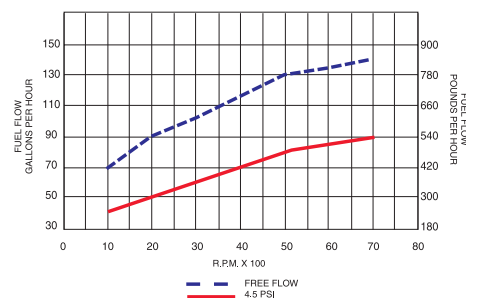

200 GPH Ultra HP Series 5 Valve Fuel Pump

Features

- Ultra HP Series flow 200 GPH free flow (gasoline)
- Made from 6061-T6 billet aluminum for durability & good looks
- Hard coat anodized for corrosion resistance
- -10 AN inlet and -8 AN outlet fittings included
- Preset shutoff pressure of 10-11 PSI
- Require fuel pressure regulator such as Holley p/n 12-704
- Bases are independently rotatable from the top for ease of installation
- All Ultra HP fuel pumps are rebuildable
- Inlet & outlet tapped for 1/2" NPT for BBC Marine

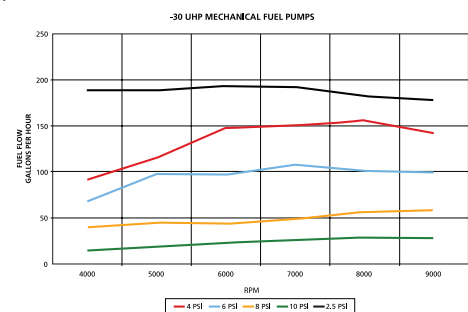

Holley Electric Marine Fuel Pumps – Carbureted Engines



67 GPH Electric Fuel Pump Part # 712-801-1

Features

- Flows 67 gallons per hour @ 5 PSI
- Pressure pre-set at 7 PSI
- Regulator not required
- Pressure relief valve is externally accessible
- Pump design is more tolerant of contaminated fuels
- Total pump weighs less than 3 lbs.
- Includes mounting bracket
- 3/8" inlet and outlet ports
- Fuel/fume tube provision
- Motor draws only 2 Amps.
- 7-1/2 Amp fuse recommended
- Gasoline and alcohol compatible
- Meets U.S. Coast Guard regulations
- Not designed or recommended for use with fuel injection systems
- 3/8 NPT inlet/outlet



70 GPH Electric Fuel Pump Part # 712-802-1

Features

- Flows 70 gallons per hour @ 9 PSI
- Pressure pre-set at 14 PSI
- Includes regulator P/N # 12-803
- Pressure relief is externally accessible
- Pump design is more tolerant of contaminated fuels
- Total pump weighs less than 3 lbs.
- Includes mounting bracket
- 3/8" inlet and outlet ports
- Fuel/fume tube provision
- Motor draws around 3 Amps.
- 7-1/2 Amp fuse recommended
- Gasoline compatible
- Meets U.S. Coast Guard regulations
- Not designed or recommended for use with fuel injection systems
- 3/8 NPT inlet/outlet



120 GPH Electric Fuel Pump Part # 712-815-1

Features

- Flows 120 gallons per hour @ 9 PSI
- Pressure pre-set at 14 PSI
- Compatible with alcohol or methanol fuel
- Pressure relief is externally accessible
- Pump design is more tolerant of contaminated fuels
- Total pump weighs less than 3 lbs.
- Includes mounting bracket
- 3/8" inlet and outlet ports
- Fuel/fume tube provision
- Motor draws around 4 Amps.
- 7-1/2 Amp fuse recommended
- Gasoline and alcohol compatible
- Meets U.S. Coast Guard regulations
- Not designed or recommended for use with fuel injection systems
- 3/8 NPT inlet/outlet



Carburetor Fuel Pressure Regulators

4-1/2 to 9 PSI, Satin finish **Part # 12-803^(B)**
 1 to 4 PSI, Satin finish **Part # 12-804^(B)**



- Features**
- 3/8" NPT ports
 - .220" (7/32") restriction
 - Includes mounting bracket
 - Low Pressure (1-4 PSI)
 - High Pressure (4-1/2-9 PSI)
 - Chrome Finish
 - Not alcohol compatible



- Features** **Part # 12-704^(B)**
- Regulates from 4-1/2 to 9 PSI
 - One 1/2" NPT inlet and two 1/2" NPT outlet ports
 - .437" (7/16") restriction
 - Includes mounting hardware and AN style fittings (one -8 and two -6)
 - Alcohol compatible



- Features** **Part # 12-707^(B)**
- Regulates from 4-1/2 to 9 PSI
 - One -8 inlet port and four -6 outlet ports
 - .437" (7/16") restriction
 - Aluminum billet body and top casting cover are hard coat anodized
 - Three fuel pressure gauge mounting options (fuel pressure gauge not included)
 - Includes mounting hardware and AN style fittings
 - Compatible for use with methanol/alcohol

Carburetor Bypass Style Fuel Pressure Regulator



- Features** **Part # 12-803BP^(B)**
- 3/8" NPT ports (1 in, 1 out, 1 bypass or return)
 - Used in systems with a return line back to the fuel tank
 - Quieter fuel pump operation
 - Designed only for carburetor use
 - Preset to 7PSI
 - Adjustable from 4-1/2 to 9 PSI
 - Electric fuel pumps only

Billet Regulator Bracket **Part # 20-120**



- Features**
- Red anodized billet construction
 - Universal design fits Holley and competitors 4150/4160 style carburetors
 - Simplifies mounting Holley fuel pressure regulators
 - Included hardware makes installation easy

HOW TO CHOOSE A CARB
 STREET CARBURETORS
 SUPERCHARGER CARBURETORS
 RACE CARBURETORS
 MARINE CARBURETORS
 CARB SERVICE PARTS & ACCESSORIES
 FUEL INJECTION
 THROTTLE BODIES
 FUEL PUMPS
 INTAKE MANIFOLDS
 CYLINDER HEADS
 SYSTEMAX
 ENGINE DRESS-UP
 MERCHANDISING
 TECHNICAL INFORMATION
 INDEX

Adjustable Fuel Pressure Regulator Part # 512-504-5

This precision adjustable fuel metering regulator is the ultimate fuel pressure control unit designed to work on all naturally aspirated EFI, turbo and supercharged applications like vehicles that run in the Pro Street, Pro Import and Outlaw classes. This is a 1:1 boost compensating return style regulator that is adjustable from 15-65 PSI + boost reference and is designed to be used in conjunction with any electric EFI fuel pump. Features built in gauge port, mounting bracket, two AN -8 O-ring fittings and a AN-6 O-ring return fitting. All racing regulators come Black hard anodized for ultimate durability.



Key Features:

- Designed to regulate high fuel demands for naturally aspirated EFI, turbo, supercharged and NOS race applications.
- Engineered to regulate extreme flow volumes generated by racing fuel systems.
- Allows adjustment from 15-65 PSI + boost reference.
- Precision CNC machined 6061 T-6 Billet aluminum.
- -8AN & -6AN O-Ring style fittings included to adapt to steel braided fuel lines.
- Includes detailed installation instructions.

Fuel Management Controller Part # 512-505

This Fuel Management unit is designed to run in conjunction with the factory fuel pressure regulator. This is the ultimate manual fuel management control unit and is installed in series with a stock regulator in the return line back to the tank. The unit increases fuel pressure in proportion to boost pressure up to a 4:1 Idle/WOT pressure ratio depending on which included adjustable disks you select. This add on upgrade is ideal to be used with aftermarket turbo and supercharger kits that require additional fuel pressure volume as the boost pressure increases. This unit is adjustable from 20-75 PSI, offers two fuel pressure slope settings and is recommended to be used in conjunction with any Holley High volume EFI fuel pump. All Fuel management units are produced from precision CNC machined billet aluminum and include detailed installation instructions.



Key Features:

- Supplies increasing fuel ratios in respect to boost produced by turbos and superchargers.
- Designed to supply additional fuel for aftermarket turbo and supercharger applications.
- Engineered to regulate extreme flow volumes generated by racing fuel systems.
- Allows adjustment from 20-75 PSI + boost reference.
- Precision CNC machined 6061 T-6 Billet aluminum.
- -6 AN fittings included.
- Includes detailed installation instructions.

EFI Fuel Pressure Regulators

Holley fuel injection pressure regulators are designed to provide the correct fuel pressure for any high performance fuel injected vehicle. Regulators for dedicated applications are offered in various colors. These each feature a range of adjustability from 35-65 PSI. They're made to bolt in the stock location, so installation is a snap!

Year	Application	Engine	P/N Clear Coat	P/N Red	P/N Blue
1997-99	Acura CL	4 cyl.	512-506	512-506-1	512-506-2
1986-00	Acura Integra	All	512-506	512-506-1	512-506-2
1986-95	Acura Legend	All	512-506	512-506-1	512-506-2
1996-00	Acura NSX	All	512-506	512-506-1	512-506-2
1995-98	Acura TL	All	512-506	512-506-1	512-506-2
1992-94	Acura Vigor	All	512-506	512-506-1	512-506-2
1984 - 87	Buick GN	3.8L Turbo	N/A	512-503-5*	N/A
1984 - 87	Buick Regal	3.8L Turbo	N/A	512-503-5*	N/A
1993 - 97	Chevrolet Camaro	LT1/LT4	512-502	512-502-1	N/A
1985 - 92	Chevrolet Camaro	5.0L TPI	512-501	N/A	N/A
1992 - 96	Chevrolet Corvette	LT1/LT4	512-507	N/A	N/A
1994 - 95	Chevrolet Impala SS	LT1	512-502	512-502-1	N/A
1986 - 94	Ford Mustang	5.0L EFI	512-500	512-500-1*†	N/A
1986 - 94	Ford Mustang	5.0L EFI	512-509	N/A	N/A
1990-00	Honda Accord	4 cyl.	512-506	N/A	N/A
1989 - 00	Honda Civic	EFI	512-506	512-506-1	512-506-2
1989-91	Honda CRX	EFI	512-506	512-506-1	512-506-2
1993-97	Honda Del Sol	All	512-506	512-506-1	512-506-2
1989-00	Honda Prelude	All	512-506	512-506-1	512-506-2
2000-01	Honda S2000	All	512-506	512-506-1	512-506-2
1993 - 97	Pontiac Firebird	LT1/LT4	512-502	512-502-1	N/A
1985 - 92	Pontiac Firebird	5.0L TPI	512-501	N/A	N/A

* Stamped steel construction with powder coated finish. All others are true CNC billet
 † Now gold zinc plated



512-506



512-509-1

Electric Fuel Pump Accessories

30 Amp Fuel Pump Relay Kit Part # 12-753



This Holley kit is intended primarily for those applications running an electric pump. The long wire runs in these kinds of installations can sometimes result in a voltage drop at the electric pump. Installation of this kit is good insurance that the fuel pump will be receiving full voltage from the battery.

Holley P/N 12-753 can be used with any electric fuel pump, as long as the current load is not above 30 Amps. It will work with 12, 16 and 24 Volt electrical systems and comes equipped with 12 AWG wires that provide extra current-carrying capacity with minimal voltage loss. A 30 Amp relay is included with a relay socket wired with long leads specifically designed to reduce the number of splices required. Quality insulated crimp connectors are provided to make the necessary splices, where required. Detailed instructions are included.

VoluMAX® Filters and Components

The Holley line of VoluMAX filters has been greatly expanded. It encompasses filter diameter sizes from 4" to 12" with single and dual inlet/outlets available. VoluMAX filters have a very high flow capacity and feature a washable, stainless steel filter screen that's available in 28, 60 and 115 micron ratings, depending on diameter.

The two-piece anodized billet aluminum housing is CNC-machined and can be rotated 360° to accommodate any required port alignment. A 3/8" mounting stud with lock washer and nut is provided to mount the filter on your bracket. VoluMAX filters can be used with gasoline, diesel fuel, oil or any fluid where the best filtration possible is required. For the ultimate filtration system, try Holley VoluMAX filters.

Flow Specs for Fuel & Engine Oil

- 28 MICRON (propane/exotic fuels)
- 60 MICRON (fuel/oil)
- 115 MICRON (transmission fluid/gear oil)



10-6002SV



10-6028S

DESCRIPTION	PART #
4" filter w/ 60 micron screen, AN -8 O-ring and 3/8 NPT ports	10-4001
4" filter w/ 60 micron/Viton® screen, AN -8 O-ring and 3/8 NPT ports	10-4001V
4" filter w/ 115 micron screen, AN -8 O-ring and 3/8 NPT ports	10-4002
4" filter w/ 115 micron/Viton® screen, AN -8 O-ring and 3/8 NPT ports	10-4002V
4" filter w/ 28 micron screen, AN -8 O-ring and 3/8 NPT ports	10-4028
4" filter w/ 28 micron Viton® screen, AN -8 O-ring and 3/8 NPT ports	10-4028V
4" 28 micron replacement screen	10-4000
4" 28 micron/Viton® replacement screen	10-4000V
4" 60 micron replacement screen	10-4010
4" 60 micron/Viton® replacement screen	10-4010V
4" 115 micron replacement screen	10-4020
4" 115 micron/Viton® replacement screen	10-4020V
4" filter housing - service replacement	10-4999
6" filter w/ 60 micron screen, AN -12 O-ring and 3/4 NPT ports	10-6001D
6" filter w/ 60 micron/Viton® screen, AN -12 O-ring and 3/4 NPT ports	10-6001DV
6" filter w/ 60 micron screen, single 3/4 NPT port	10-6001S
6" filter w/ 60 micron/Viton® screen, single 3/4 NPT port	10-6001SV
6" weld-on w/ 60 micron screen, single 3/4 NPT port	10-6001WS
6" filter w/ 115 micron screen, AN -12 O-ring and 3/4 NPT ports	10-6002D
6" filter w/ 115 micron/Viton® screen, AN -12 O-ring and 3/4 NPT ports	10-6002DV
6" filter w/ 115 micron screen, single 3/4 NPT port	10-6002S
6" filter w/ 115 micron/Viton® screen, single 3/4 NPT port	10-6002SV
6" filter w/ 28 micron screen, AN -12 O-ring and 3/4 NPT ports	10-6028D
6" filter w/ 28 micron/Viton® screen, AN -12 O-ring and 3/4 NPT ports	10-6028DV
6" filter w/ 28 micron screen, single 3/4 NPT port	10-6028S
6" filter w/ 28 micron/Viton® screen, single 3/4 NPT port	10-6028SV
6" 28 micron replacement screen	10-6000
6" 28 micron/Viton® replacement screen	10-6000V
6" 60 micron replacement screen	10-6010
6" 60 micron/Viton® replacement screen	10-6010V
6" 60 micron multi-screen kit	10-6030S
6" 115 micron replacement screen	10-6020
6" 115 micron/Viton® replacement screen	10-6020V
6" filter housing, service replacement, dual ports	10-6999D
6" filter housing, service replacement, single port	10-6999S
9" filter w/ 28 micron/Viton® screen, AN -18 and 7/8 NPT ports	10-9028DANPV
9" filter w/ 28 micron/Viton® screen, dual AN -18 ports	10-9028DANV
9" filter w/ 28 micron/Viton® screen, single AN -18 port	10-9028SANV
9" filter w/ 28 micron/Viton® screen, single 7/8 NPT port	10-9028SV
9" 28 micron/Viton® replacement screen	10-9000V
9" filter w/ 60 micron/Viton® screen, AN -18 and 7/8 NPT ports	10-9060DANPV
9" filter w/ 60 micron/Viton® screen, dual AN -18 ports	10-9060DANV
9" filter w/ 60 micron/Viton® screen, single AN -18 port	10-9060SANV
9" filter w/ 60 micron/Viton® screen, single 7/8 NPT port	10-9060SV
9" 60 micron/Viton® replacement screen	10-9010V
12" filter w/ 28 micron/Viton® screen, single 1-1/4 NPT port	10-12028SV
12" filter w/ 28 micron/Viton® screen, single AN -24 port	10-12028SANV
12" 28 micron/Viton® replacement screen	10-12000V
12" filter w/ 60 micron/Viton® screen, single 1-1/4 NPT port	10-12060SV
12" filter w/ 60 micron/Viton® screen, single AN -24 NPT port	10-12060SANV
12" filter w/ 60 micron/Viton® screen, dual AN -24 O-ring ports	10-12060DANV
12" 60 micron/Viton® replacement screen	10-12010V

Viton® is a registered trademark of Dupont Performance Elastomers

HOW TO CHOOSE A CARB
STREET CARBURETORS
SUPERCHARGER CARBURETORS
RACE CARBURETORS
MARINE CARBURETORS
CARB SERVICE PARTS & ACCESSORIES
FUEL INJECTION
THROTTLE BODIES
FUEL PUMPS
INTAKE MANIFOLDS
CYLINDER HEADS
SYSTEMAX
ENGINE DRESS-UP
MERCHANDISING
TECHNICAL INFORMATION
INDEX

VoluMAX® Fuel Filters



162-515



162-514



162-516



162-518

VoluMAX fuel filters have a very high flow capacity and feature a washable stainless steel, 60- micron filter element. The two-piece black anodized billet aluminum housing is CNC machined and can be rotated 360° to accommodate any required port alignment. A 3/8" mounting stud with lock washer and nut is provided to mount on your bracket.

Single inlet/outlet (-8 AN O-ring fittings) **Part # 162-514**
 Dual inlet/outlet (-8 AN O-ring fittings) **Part # 162-515**

This filter features a tube-style design. It holds a very fine 7 micron paper element that's capable of filtering up to 750 gallons of fuel an hour. The filter is constructed of .150" wall aluminum tubing with an outer diameter of 2.5" and a length of 10". Removable end caps have AN pipe threads and are sealed with an O-ring. The caps have female 1/2" pipe threads so any fitting can be installed. The filter is anodized for appearance and protection against corrosion. **Part # 162-517**

Replacement filter element for VoluMAX fuel filter. The fine 60 micron stainless steel screen is washable.
 One per package. **Part # 162-516**

Replacement paper filter element for 162-517 fuel filter **Part # 162-518**

Electric Fuel Pump Service Kits



B.



C.



D.



A.



E.



F.



G.

12-801-1 (red), 12-802-1 (blue), and 12-815-1 (black) Fuel Pumps

PART NO.	DESCRIPTION	APPLICATION
A. 12-805	Check valve kit	12-801-1 pump
A. 12-806	Check valve kit	12-802-1 pump
A. 12-816	Check valve kit	12-815-1 pump
B. 12-819 NEW	Check valve kit	12-125 HP pump
C. 12-820 NEW	Check valve kit	12-150 HP pump
D. 12-821 NEW	Gerotor kit	12-125 & 12-150 pumps
E. 12-807	Diaphragm repair kit	12-803, 12-804 regulators
F. 12-810	Safety pressure switch	All electric pumps
G. 12-811	Rotor and vane kit	12-801-1, 12-802-1 pumps
H. 12-818	Diaphragm repair kit	12-803BP regulator

Continued on next page 132

HOW TO CHOOSE A CARB STREET CARBURETORS SUPERCHARGER CARBURETORS RACE CARBURETORS MARINE CARBURETORS CARB SERVICE PARTS & ACCESSORIES FUEL INJECTION THROTTLE BODIES FUEL PUMPS INTAKE MANIFOLDS CYLINDER HEADS SYSTEMAX ENGINE DRESS-UP MERCHANDISING TECHNICAL INFORMATION INDEX

Electric Fuel Pump Service Kits (Cont'd)

12-705-1 and 12-706-1 VOLUMAX Fuel Pumps

PART NO.	DESCRIPTION	APPLICATION
I. 12-751	Gasket kit/Check Valve kit	12-705, 12-706 pumps

Fuel Pump Block-Off Plates – Chrome

PART NO.	DESCRIPTION	APPLICATION
J. 12-813	Mechanical fuel pump mounting pad cover	Big block Chrysler, Small block Chrysler
K. 12-814	Mechanical fuel pump mounting pad cover	Big block Chevrolet, Small block Chevrolet



I.



J.



K.

Ultra HP Mechanical Fuel Pump Service Parts

Hardware Kit

(stainless steel) **Part# 12-760**

4 socket head cap screws (8-32 x 3/8"); 6 socket head cap screws (10-32 x 5/8"); 2 socket head cap screws (1/4"-20 x 1"); 2 AN crush washers; 1 set screw (5/16"-24 x 1/4"); 1 set screw (8-32 x 1/8")

Arm Replacement Kit

1 fuel pump lever arm for small block Chevy. **Part # 12-763**

1 spring (fuel pump lever arm return) for big block Chevy. **Part # 12-764**

1 fulcrum pin for small block Ford **Part # 12-765**

Valve Body

Replacement Kit **Part# 12-762**

1 new valve body

Diaphragm Assembly (Low Pressure)

-30 & -40 pumps **Part# 12-755**

1 low pressure diaphragm assembly

Diaphragm Assembly (High Pressure)

-35 pumps **Part# 12-756**

1 high pressure diaphragm assembly

Gasket

Replacement Kit **Part# 12-757**

1 valve body to bottom gasket; 1 rubber pulsator; 1 engine mounting gasket; 1 sintered bronze breather vent; 1 brass hose barb

VoluMAX™ Regulator Service Parts for 12-704 & 12-707

PART NO.	APPLICATION
L. 12-752	Diaphragm
26-90	O-ring Kit for AN fittings
M. 26-88	(-8 AN) Fitting for 12-707



L.



M.



INTAKE MANIFOLDS

INTAKE MANIFOLDS 142-146

Chevrolet Small Block V8	142-143
Chevrolet Big Block V8	144-145
Chrysler Big Block V8	145
Ford Small Block V8	145
Service Parts	146

Chevrolet Small Block V8



Competition motors built for circle track and drag racing with 23° standard port heads **Part # 300-110^(c)**

Features

- Exclusive Keith Dorton one-piece design
- 4500-8500 RPM power band
- Holley model 4150 carburetor mounting flange
- Ideal for classes running cast iron heads with un-ported manifolds, per class rules
- Single plenum is designed to provide a highly efficient fuel charge with maximum velocity at the ports so as to maintain crisp throttle response

CARBURETOR RECOMMENDATIONS:
 0-80507-2 (390 CFM);
 0-80785 (830 CFM),

SPECIFICATIONS:
 Height- frt. 6.13"; rr 6.13"
 Port size: 2.00" height;
 1.20" width

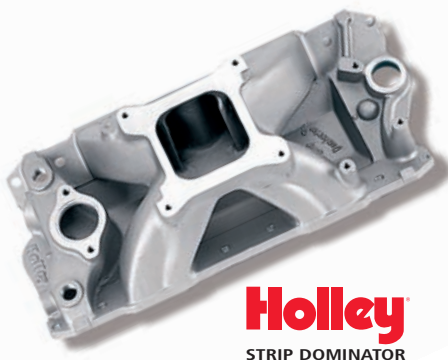

1957-86; 262, 283, 305, 327, 350, 400V8
 1987-Later w/Aluminum Heads **Part # 300-25^(B)**

Features

- 4500-7600 RPM power band
- Single plane/open deep plenum design
- Square flange carburetor mounting
- No exhaust heat crossover provision
- Ideal for drag cars with automatic transmission

CARBURETOR RECOMMENDATIONS:
 750 - 850 CFM Holley HP

SPECIFICATIONS:
 Height - frt. 5.11", rr. 5.97".
 Port size: 2.05" height; 1.22" width



1957-86; 262, 283, 305, 327, 350, 400V8
 1987-Later w/Aluminum Heads **Part # 9901-101-1^(B)**

Features

- 2000-6000 RPM power band
- Designed for port fuel injection systems
- Accepts 1000 CFM Holley 4-bbl throttle body - P/N 9900-171
- Single plane manifold design

INSTALLATION:
 Fuel Rail Kit available. Order Holley P/N 9900-172 Performance Fuel Injector Kits available.

SPECIFICATIONS:
 Height - frt. 5.5", rr. 5.5".
 Port size: 1.89" height; 1.12" width



350 V8 with Gen 1, Vortec cylinder heads **Part # 9901-107^(B)**

Features

- 2000-6000 RPM power band
- Designed for port fuel injection systems
- Accepts 1000 CFM Holley 4-bbl throttle body P/N 9900-171
- Single plane manifold design

INSTALLATION:
 Fuel Rail Kit available. Order Holley P/N 9900-172 Performance Fuel Injector Kits available.

SPECIFICATIONS:
 Height - frt. 5.75", rr. 5.75"
 Port size: 2.09" height; 1.10" width

HOW TO CHOOSE A CARB
 STREET CARBURETORS
 SUPERCHARGER CARBURETORS
 RACE CARBURETORS
 MARINE CARBURETORS
 CARB SERVICE PARTS & ACCESSORIES
 FUEL INJECTION
 THROTTLE BODIES
 INTAKE MANIFOLDS
 CYLINDER HEADS
 SYSTEMAX
 ENGINE DRESS-UP
 MERCHANDISING
 TECHNICAL INFORMATION
 INDEX

Chevrolet Small Block V8



1957-86; 262, 283, 305, 327, 350, 400V8
 1987-Later w/Aluminum Heads.....

Part # 7540^(C)
 (satin finish)

Part # 7540P^(C)
 (polished finish)

Features

- 23° Standard port heads
- Idle - 6,500 RPM power band
- Two-piece design features short individual runners and large upper plenum
- D-shaped manifold ports promote high flow rates without turbulence
- Excellent replacement for TPI engines (requires P/N 90748 angled bolt spacers)

INSTALLATION:

Great for Street Rods or Early Muscle Cars with ample hood clearance.
 Use Holley 2x58mm - P/N 112-503 throttle body or stock Chevrolet LT1 throttle body (not included) Requires use of small cap distributor

SPECIFICATIONS:

Height (w/ Plenum)
 - frt. 10.25", rr. 10.25"
 Port size: 1.92" height; 1.18" width



262-400 SB using 1996 & later
 Vortec (L31) iron heads.....

Part # 7542^(C)
 (satin finish)

Part # 7542P^(C)
 (polished finish)

Features

- Great for street machines, street rods, trucks and muscle cars with ample hood clearance
- Two-piece design features individual D shaped runners optimized for a broad power range and a large plenum area for less reversion than traditional manifolds
- Can be used for blow-through superchargers and turbochargers in custom applications
- Available in satin or polished
- Fully CNC machined for a perfect fit
- No exhaust crossover

SPECIFICATIONS:

- Power band: Idle to 6500RPM
- Overall Height - frt. 10.25", rr. 10.25"
- Weight is 25 lbs.
- 7542 port size: 2.10" height; 1.12" width

INSTALLATION NOTES:

- Use Holley 2x58mm billet throttle body (p/n 112-503 or 112-507) or stock TPI throttle body
- Requires use of small cap distributor
- Manifold features universal mounting bolt design engineered to accommodate both straight and angled center manifold bolts (requires P/N 90748 Weiland bolt kit for 1987 & later cast iron)
- Accepts stock or Lokar® TPI kickdown brackets
- May require additional sealing modifications for high boost blow through applications
- Recommended Fel-Pro gasket number: (7542) MS90131-2 (plastic body w/ o-ring seals) or MS98000T (Permadry, highly recommended)

(C) Not legal for street use with a 4-barrel in California on vehicles equipped with a 2 barrel carb, for which there was no 4-barrel option

or See page 223 for symbol explanation.

HOW TO CHOOSE A CARB
 STREET CARBURETORS
 SUPERCHARGER CARBURETORS
 RACE CARBURETORS
 MARINE CARBURETORS
 CARB SERVICE PARTS & ACCESSORIES
 FUEL INJECTION
 THROTTLE BODIES
 FUEL PUMPS
INTAKE MANIFOLDS
 CYLINDER HEADS
 SYSTEMS
 ENGINE DRESS-UP
 MERCHANDISING
 TECHNICAL INFORMATION
 INDEX

Chevrolet Big Block V8

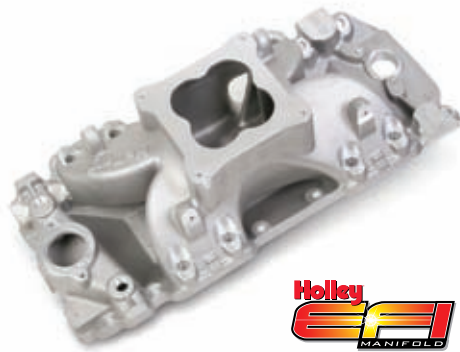

396, 402, 427, 454, 502 V8 Oval port heads **Part # 9901-209^(B)**

Features

- 2500-6000 RPM power band
- Standard deck blocks
- Single plane manifold design
- Designed for port fuel injection systems
- Accepts 1000 CFM Holley 4-bbl throttle body - P/N 9900-171

INSTALLATION:

Will fit tall blocks with use of WEIAND manifold spacer plate kit, P/N 8206.
Fuel rail kit available. Order Holley P/N 9900-173.
Performance fuel injection kits available.

SPECIFICATIONS:

Height - frt. 7.25", rr. 7.25".
Port size: 1.57" height; 1.60" width



396, 402, 427, 454, 502 V8 Rectangular port heads **Part # 9901-201^(B)**

Features

- Machined for standard deck blocks
- 2500-6000 RPM power band
- Single plane manifold design
- Designed for port fuel injection systems
- Accepts 1000 CFM Holley 4-bbl throttle body - P/N 9900-171

INSTALLATION:

Fuel rail kit available. Order Holley P/N 9900-173.
Performance fuel injection kits available.

SPECIFICATIONS:

Height - frt. 7.13", rr. 7.13".
Port size: 2.30" height; 1.60" width

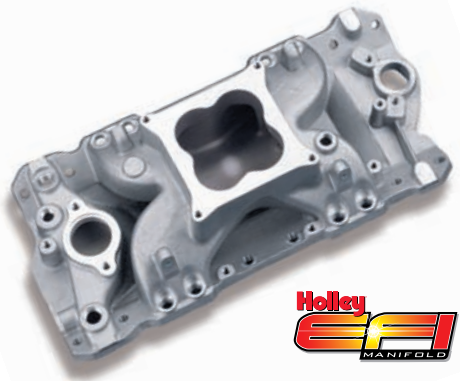

396, 402, 427, 454, 502 V8 Rectangular port heads **Part # 9901-202^(B)**

Features

- Machined for standard deck blocks
- 3000-6500 RPM power band
- Designed for port fuel injection systems
- Accepts 2000 CFM Holley 4-bbl throttle body - P/N 112-538
- Single plane manifold design

INSTALLATION:

Fuel rail kit available. Order Holley P/N 9900-173.
Performance fuel injection kits available.

SPECIFICATIONS:

Height - frt. 7.13", rr. 7.13"
Port size: 2.30" height; 1.60" width



396, 402, 427, 454, 502 Rectangular Port V8 **Part # 9901-203^(B)**

Features

- Machined for tall deck blocks
- 2500-6000 RPM power band using stock lifters
- Designed for port fuel injection systems
- Accepts 1000 CFM Holley 4-bbl throttle body - P/N 9900-171
- Single plane manifold design

INSTALLATION:

Fuel rail kit available. Order Holley P/N 9900-173.
Performance fuel injection kits available.

SPECIFICATIONS:

Height - frt. 7.123", rr. 7.13"
Port size: 2.30" height; 1.60" width

HOW TO CHOOSE A CARB
STREET CARBURETORS
SUPERCHARGER CARBURETORS
RACE CARBURETORS
MARINE CARBURETORS
CARB SERVICE PARTS & ACCESSORIES
FUEL INJECTION
THROTTLE BODIES
INTAKE MANIFOLDS
CYLINDER HEADS
SYSTEMAX
ENGINE DRESS-UP
MERCHANDISING
TECHNICAL INFORMATION
INDEX

Chevrolet Big Block V8



396, 402, 427, 454, 502 Rectangular Port V8 **Part # 9901-204^(B)** ◆

Features

- Machined for tall deck blocks
- 3000-6500 RPM power band
- Designed for port fuel injection systems
- Accepts 2000 CFM Holley 4-bbl throttle body - P/N 112-538
- Single plane manifold design

INSTALLATION:

Fuel rail kit available. Order Holley P/N 9900-173. Performance fuel injection kits available.

SPECIFICATIONS:

Height - frt. 7.13", rr. 7.13"
Port size: 2.30" height; 1.60" width

Chrysler Big Block V8



413, 426 Wedge and 440 V8 **Part # 300-14^(C)** ◆

Features

- Single plane manifold design
- 1500-6500 RPM power band
- Provision for EGR and choke
- Universal flange carburetor mounting

CARBURETOR RECOMMENDATIONS:

0-80508S (750 CFM);
0-4779S (750 CFM)

SPECIFICATIONS:

Height - frt. 4.13", rr. 5.25"
Port size: 2.14" height;
1.12" width

"Biggest average numbers" in July 2002 Mopar Muscle magazine manifold shoot-out!

Ford Small Block V8



300-74S

5.0L EFI 1986-93 Passenger Car EO# D115-11 **Part # 300-72S**
(complete manifold kit Shiny Finish)

Don't be fooled by its California emission-legal designation. This manifold will flow air like no other street/street manifold. It's fully machined and ready to bolt down on an engine.

Part # 300-74S

(upper manifold only)

Part # 300-75S

(lower manifold only)

Features

- 2000-6500 RPM power band
- Retains stock injector and water outlet locations
- External EGR passage maximized port and runner sizes
- Maximum unrestricted air flow
- Lower manifold ports match up to Holley cylinder head

INSTALLATION:

Check out Holley's new line of high-flow throttle bodies, in-tank fuel pumps, adjustable regulators, cylinder head and camshafts for the Ford 5.0L EFI passenger engine.

SPECIFICATIONS:

Shipping weight is 45 lbs.
Height - frt. 10.625", rr. 10.625"

NOTE: Must use Holley valve covers P/N 241-81 or similar

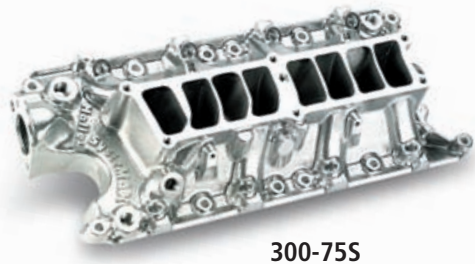

300-75S

(C) Not legal for street use with a 4-barrel in California on vehicles equipped with a 2 barrel carb, for which there was no 4-barrel option

◆ ◆ or ◆ See page 223 for symbol explanation.

HOW TO CHOOSE A CARB
STREET CARBURETORS
SUPERCHARGER CARBURETORS
RACE CARBURETORS
MARINE CARBURETORS
CARB SERVICE PARTS & ACCESSORIES
FUEL INJECTION
THROTTLE BODIES
FUEL PUMPS
INTAKE MANIFOLDS
CYLINDER HEADS
SYSTEMAX
ENGINE DRESS-UP
MERCHANDISING
TECHNICAL INFORMATION
INDEX

SPACER KITS

Chevrolet Standard Big Block Manifold to Chevrolet Tall Deck (oval port) Part # 8206

This intake manifold spacer kit allows the use of any high performance big block Chevrolet manifold on late model Chevrolet "tall deck" truck engines. This spacer fits in the gap created by the taller deck height of the truck blocks. **NOTE:** Due to the increased manifold height, use of an aftermarket distributor is necessary. Spacer plate thickness: .375". Shipping weight is 4 lbs.



Chevrolet Standard Big Block Manifold to Chevrolet Tall Deck (rectangular port) Part # 8204

This intake manifold spacer kit allows the use of any high performance big block Chevrolet manifold on late model Chevrolet "tall deck" truck engines. This spacer fits in the gap created by the taller deck height of the truck blocks. **NOTE:** Due to the increased manifold height, use of an aftermarket distributor is necessary. Spacer plate thickness: .375". Shipping weight is 4 lbs.



NOTE: Notches for manifold bolts between ports have been eliminated from these spacer plates.

Intake Manifold Choke Kits

Choke block-off pad for some Chevrolet small block engine intake manifolds. Part # 301-20



Choke adapter allows use of horizontal-mount choke element on Chevrolet manifolds with angle-mount-type choke elements. Part # 9003



Intake Manifold Choke Kits

EGR block-off plate for Chevrolet small block manifolds Part # 9007



Plenum divider plate. Used in manifold #7546. Part # 9008



Intake Manifold Gaskets

SystemAX II upper and lower manifold. Kormetal gasket used between the Holley SystemAX II Ford 5.0L upper and lower manifolds Part # 108-80

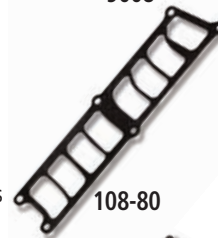

Gasket for Holley Pro Dominator 2x4 tunnel ram manifolds. Used between upper and lower sections of manifolds

- Manifold P/N 300-44 (S/B Chevrolet) Part # 108-79

- Manifold P/N 300-45 (B/B Chevrolet) Part # 108-78

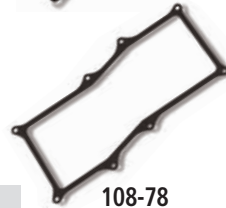

Manifold Installation Kit

Ford SystemAX II upper and lower manifold. This kit contains all the necessary items needed to install the Holley SystemAX II upper and lower manifolds on a 5.0L H.O. motor. **NOTE:** This kit is not required for manifolds manufactured after 2/01/2002 w/ internal EGR Part # 301-44



2 X 4 TUNNEL RAM CARBURETOR LINKAGE KITS

2 x 4 carburetor linkage kits utilize spherical rod bearings with stainless steel splined shafts. They are infinitely adjustable and easy to install. They all are designed to fit Holley Double Pumper™ carburetors.

LINKAGE PART #	APPLICATION	MOUNTING STYLE	CARB MODEL
4000	Universal	in-line	square bore
4021	Chevrolet 262-400	side-by-side	square bore
4022	Chevrolet 396-454-502	side-by-side	square bore
4023	Chrysler all (exc. Hemi)	side-by-side	square bore
4025	Ford 289-302 (inc. BOSS) & 351C	side-by-side	square bore
4027	429 Wedge & 460	side-by-side	square bore
4032	Chevrolet 396-454-502	side-by-side	DOMINATOR

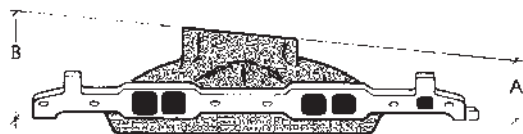
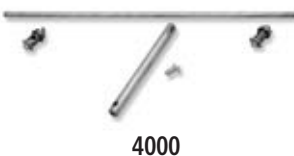

Determining Manifold Height

The manifold height measurements "A" (front) and "B" (rear), shown in the illustration (left), are determined in the following manner. Lay in a straight edge across the carburetor mounting pad. The measurements are taken from the manifold front and rear mounting surfaces to the bottom of the straight edge. To ensure adequate hood clearance, check the stock manifold height in the same manner and compare with the dimensions listed for the particular manifold of your choice.

HOW TO CHOOSE A CARB
STREET CARBURETORS
SUPERCHARGER CARBURETORS
RACE CARBURETORS
MARINE CARBURETORS
CARB SERVICE PARTS & ACCESSORIES
FUEL INJECTION
THROTTLE BODIES
INTAKE MANIFOLDS
CYLINDER HEADS
SYSTEMAX
ENGINE DRESS-UP
MERCHANDISING
TECHNICAL INFORMATION
INDEX

CYLINDER HEADS



CYLINDER HEADS 148-150

Chevrolet Small Block	148
Chevrolet Big Block – Oval Port	149
Ford Small Block	150

Small Block Chevrolet

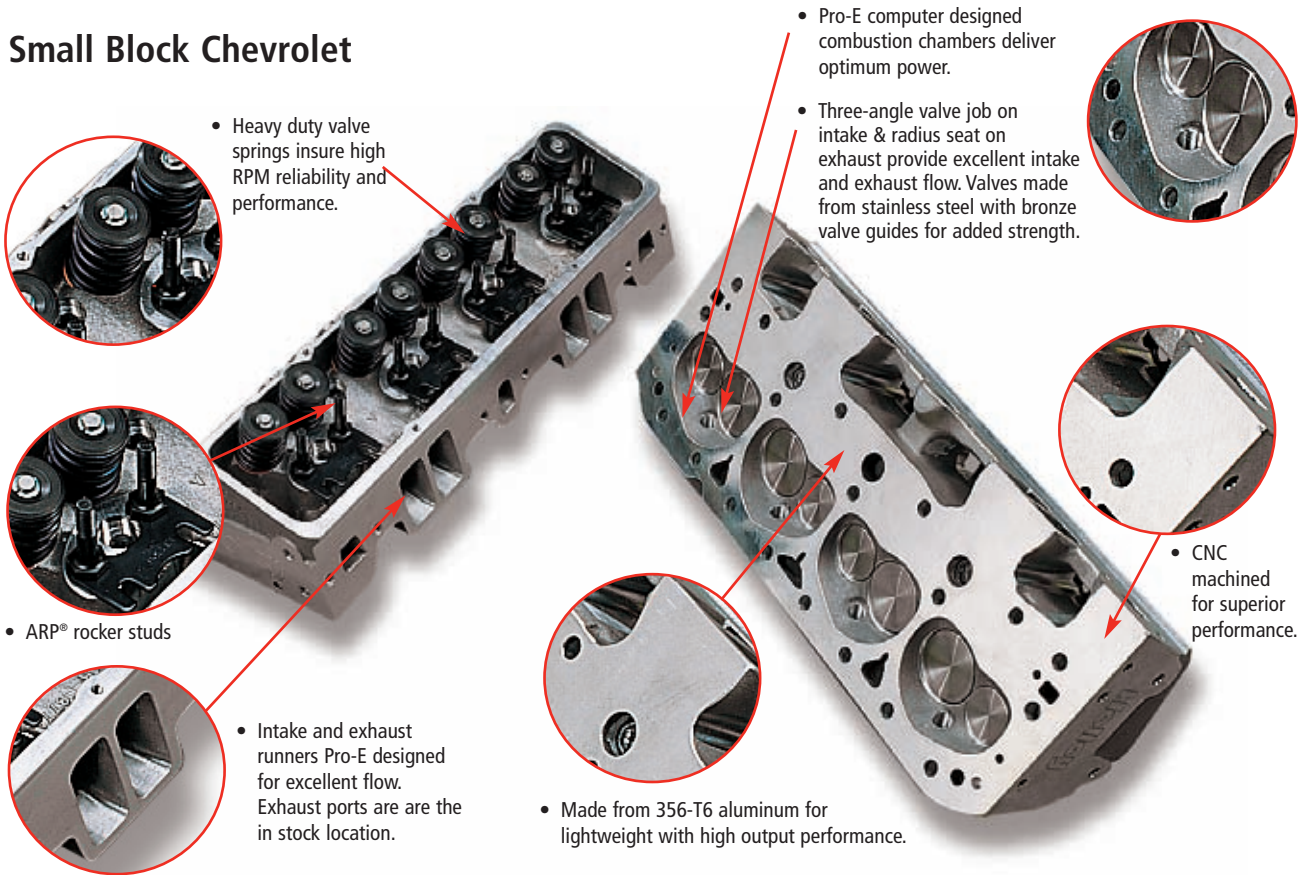

Part #	Valve Angle	Intake Runner volume	Exhaust Runner volume	Combustion chamber volume	CFM flow @ .500" lift measured @ 28" H ₂ O		Intake Valve diameter	Exhaust Valve diameter	Spark Plug angle
					Intake	Exhaust			
300-552-1	20	184cc	68cc	68cc	223	173	2.02"	1.60"	straight

Deck thickness	Exhaust Port location	Heat Crossover passage?	Rocker Arm mounting	Rocker Stud diameter	Valve Guides	Valve Spring Installed Height	Maximum lift	Valve spring seat force	Aluminum head weight
.500"	stock	yes	stud	3/8"	bronze	1.780"	.600"	132 lbs	30 lbs.

ARP cylinder head bolt kit: Holley # 301-35
 Cylinder head gaskets: Fel-Pro #1003 or equivalent
 Intake manifold gaskets: Fel-Pro #1205 or equivalent
 Exhaust manifold gaskets: Earl's # 29D03BERL or equivalent
 Valve cover gaskets: Earl's # 29E03BERL or equivalent

NOTE: Use Autolite Spark Plug: #3934 (race), #3924 (street)

425 HP @ 6150 RPM **425 LB/FT @ 4250 RPM**

— POWER — TORQUE

NOTE: Following data run at 36 degrees BTDC timing

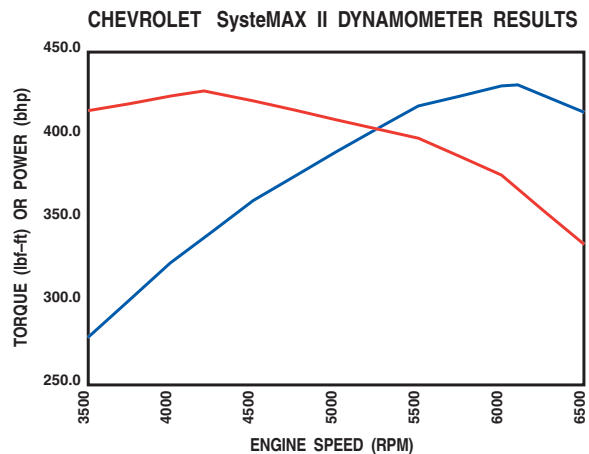

Big Block Chevrolet - Oval Port

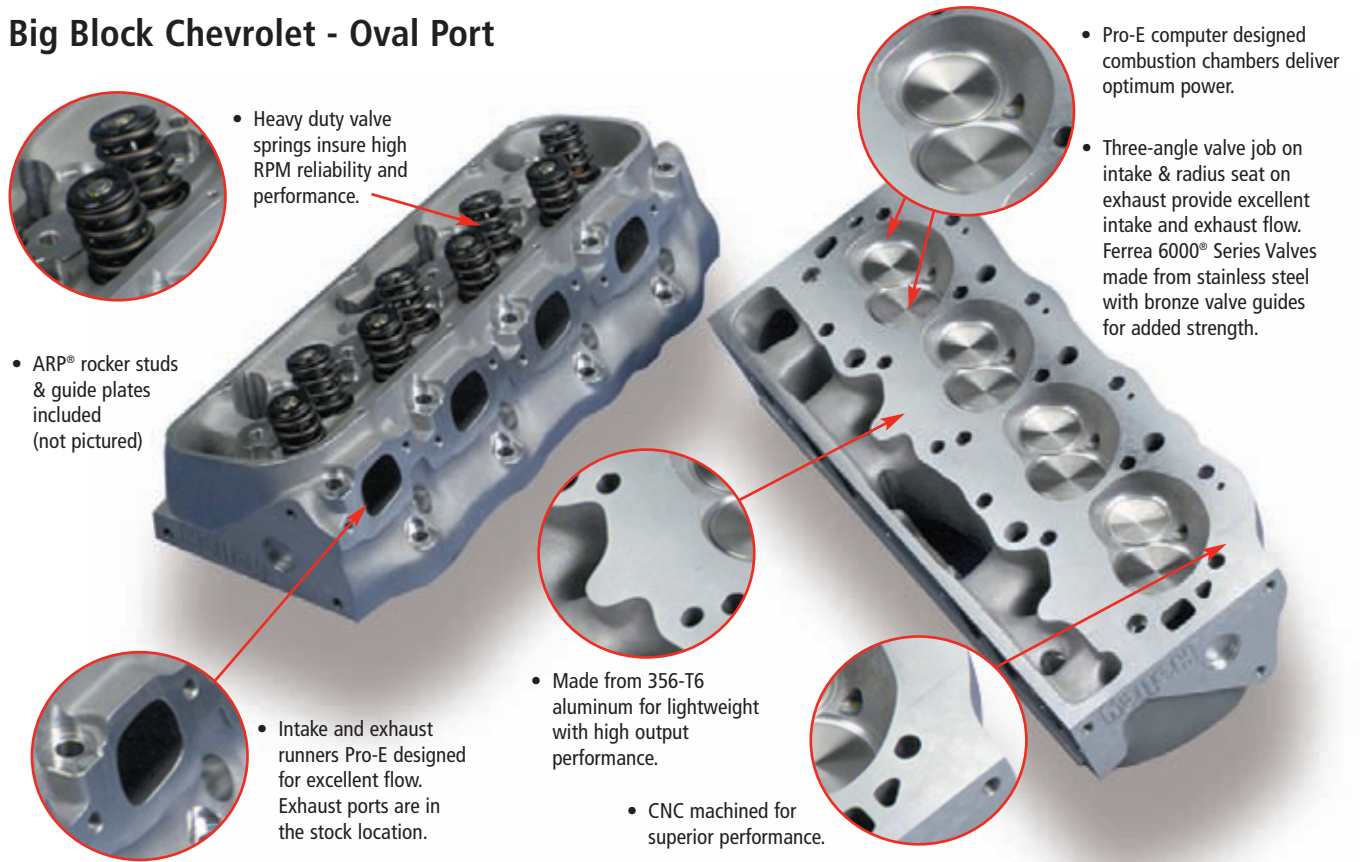

Part #	Valve Angle	Intake Runner volume	Exhaust Runner volume	Combustion chamber volume	CFM flow @ .500" lift measured @ 28" H ₂ O		Intake Valve diameter	Exhaust Valve diameter	Spark Plug angle
					Intake	Exhaust			
300-556*	24.5	274cc	119cc	110cc	292	213	2.19"	1.88"	straight

Deck thickness	Exhaust Port location	Heat Crossover passage?	Rocker Arm mounting	Rocker Stud diameter	Valve Guides	Valve Spring Installed Height	Maximum lift	Valve spring seat force	Aluminum head weight
.563"	stock	yes	stud	7/16"	bronze	1.900"	.700"	130 lbs	38 lbs.

* Includes exhaust crossover for EGR or street use.

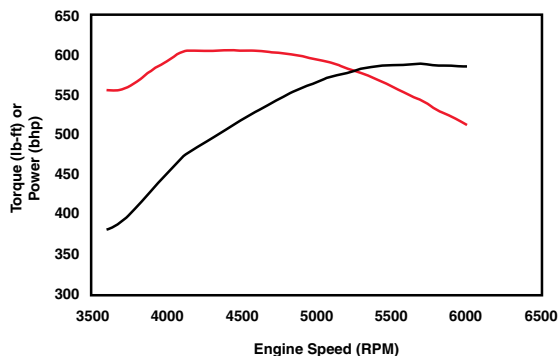

ARP cylinder head bolt kit: ARP # 135-3610
 Cylinder Head Gaskets: Fel-Pro #1017-1 or equivalent for Gen IV blocks
 Intake manifold gaskets: Fel-Pro #1212 or equivalent
 Exhaust manifold gaskets: Earl's # 29D04BERL or equivalent
 Valve cover gaskets: Earl's # 29E04BERL or equivalent

589 HP @ 5800 RPM **605 LB/FT @ 4400 RPM**
 POWER TORQUE
 Test engine: GM 502 short block

HOW TO CHOOSE A CARB FUEL PUMPS INTAKE MANIFOLDS CYLINDER HEADS SYSTEMAX ENGINE DRESS-UP MERCHANDISING TECHNICAL INFORMATION INDEX

Small Block Ford

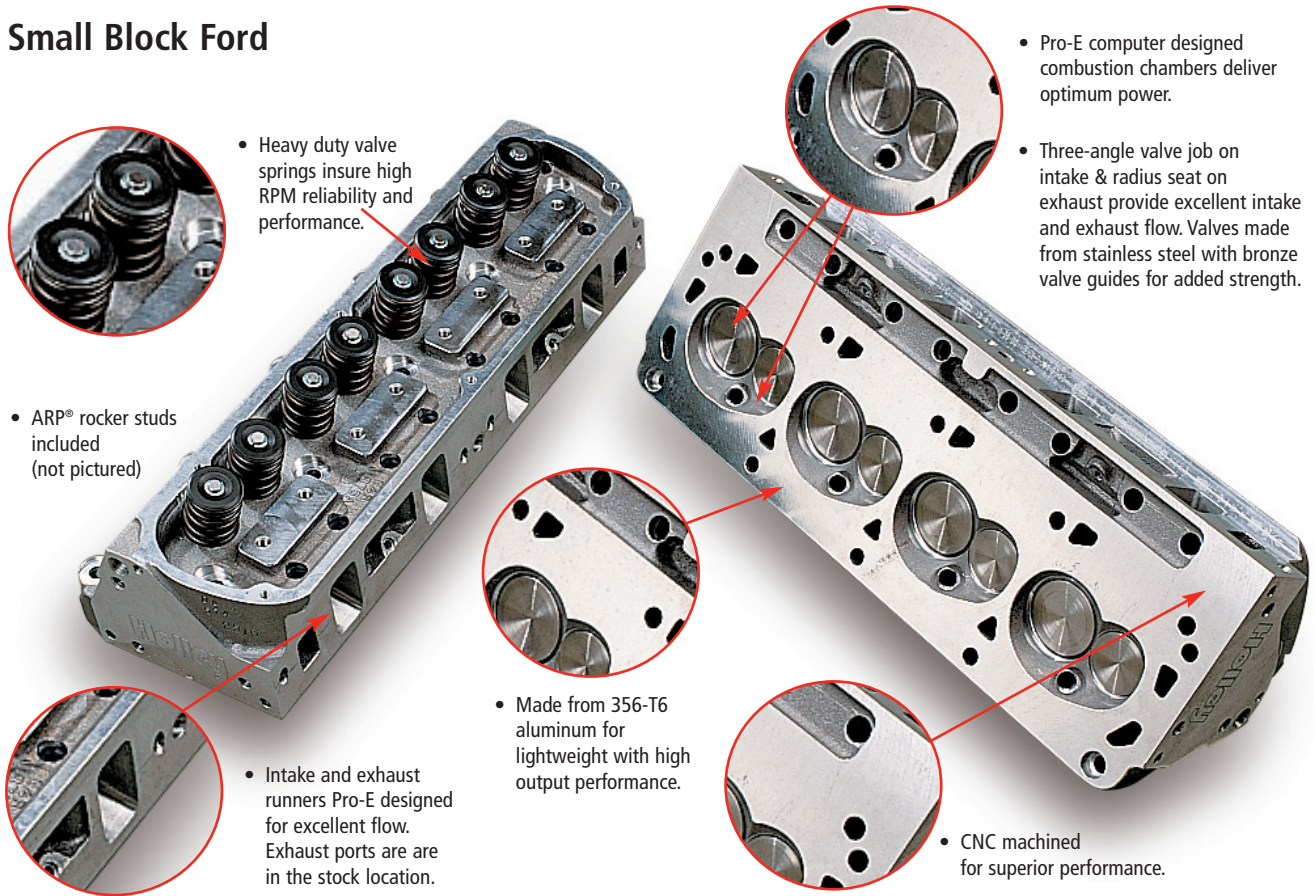

• Heavy duty valve springs insure high RPM reliability and performance.

• Pro-E computer designed combustion chambers deliver optimum power.

• Three-angle valve job on intake & radius seat on exhaust provide excellent intake and exhaust flow. Valves made from stainless steel with bronze valve guides for added strength.

• ARP® rocker studs included (not pictured)

• Made from 356-T6 aluminum for lightweight with high output performance.

• Intake and exhaust runners Pro-E designed for excellent flow. Exhaust ports are in the stock location.

• CNC machined for superior performance.

Part #	Valve Angle	Intake Runner volume	Exhaust Runner volume	Combustion chamber volume	CFM flow @ .500" lift measured @ 28" H ₂ O		Intake Valve diameter	Exhaust Valve diameter	Spark Plug angle
					Intake	Exhaust			
300-575	17	165cc	71cc	63cc	228	164	2.02"	1.60"	angled

Deck thickness	Exhaust Port location	Heat Crossover passage?	Rocker Arm mounting	Rocker Stud diameter	Valve Guides	Valve Spring Installed Height	Maximum lift	Valve spring seat force	Aluminum head weight
.500"	raised .100"	yes	stud	3/8"	bronze	1.780"	.600"	132 lbs	28 lbs.

ARP cylinder head bolt kit: Holley # 301-31

Cylinder head gaskets: Fel-Pro #1011 or equivalent

Intake manifold gaskets: Fel-Pro #1250 or equivalent

Exhaust manifold gaskets: Earl's # 29D03AERL or equivalent

Valve cover gaskets: Earl's # 29E03AERL or equivalent

NOTE: Use Autolite Spark Plug: #65

350 HP @ 5750 RPM
350 LB/FT @ 4000 RPM

— POWER — TORQUE

FORD SystemAX II Dynamometer Test Results

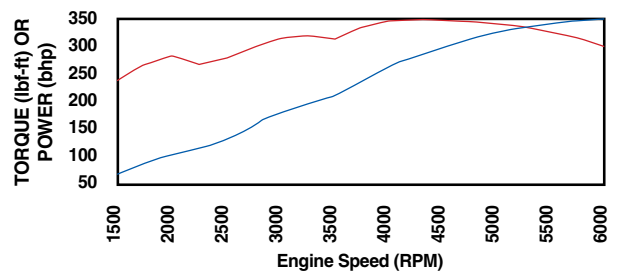

SYSTEMAX® 152 - 156

Overview	152
Chevrolet Small Block V8	153-154
Ford 5.0L EFI Kits	155
Engine Components	156

SystemAX® Engine Kits - An Overview



SystemAX engine packages are systems designed to take the guesswork out of choosing the correct combination of components that will best MAXimize the performance of a small block/big block Chevrolet engine or a small block Ford engine. They are total air flow management systems composed of matched components that, working in unison will enable you to achieve a level of performance and power that you always dreamed about.

The following are available:

SystemAX P/N	Engine Application	Horsepower
300-501-1	Ford 5.0 L (EFI)	350 @ 5750 RPM
300-502	Chevrolet 350 (carbureted)	350 @ 4500 RPM
300-503-1	Chevrolet 350 (carbureted)	425 @ 6100 RPM

The Ford 5.0 L EFI systems are designed specifically for the 1986-93 EFI engines. All kits are available either carbureted or fuel injected.

SystemAX kits feature top quality Holley, Lunati and Weiand brand components such as cylinder heads, intake manifold, timing chain and gear set and camshaft and lifters. Carburetors are not included, but a Holley carburetor recommendation is made that's based on dynamometer testing results.

SystemAX is designed to be delivered as a complete kit because it ideally matches the components for maximum performance. For those on a budget, however, Holley offers SystemAX on a component basis.



Chevrolet Small Block V8 - (1962-86) Part # 300-502^(B)

Comments/ Recommendations

A potent, but very driveable street package for a basic stock motor. Add Hooker or FlowTech headers and a 750 CFM vacuum secondary Holley carburetor to tie this package together.

Vital Statistics

Engine production years: 1962-86
 Horsepower: 350HP @ 4500 RPM
 Torque: 357 lbs./ft. @ 3500 RPM

Kit Contents

Lunati hydraulic camshaft and lifters, P/N 06108LK
 Holley dual plane aluminum intake manifold, P/N 8120
 Double roller timing chain and gears
 Assembly lube



Camshaft Specifications

Intake valve gross lift/duration: .457"/268°
 Exhaust valve gross lift/duration: .457"/268°
 Intake valve duration @ .050": 218°
 Exhaust valve duration @ .050": 218°
 Rocker arm ratio: 1.5
 Intake valve lobe centerline: 105°
 Lobe separation: 110°

CHEVROLET SystemAX I DYNAMOMETER RESULTS

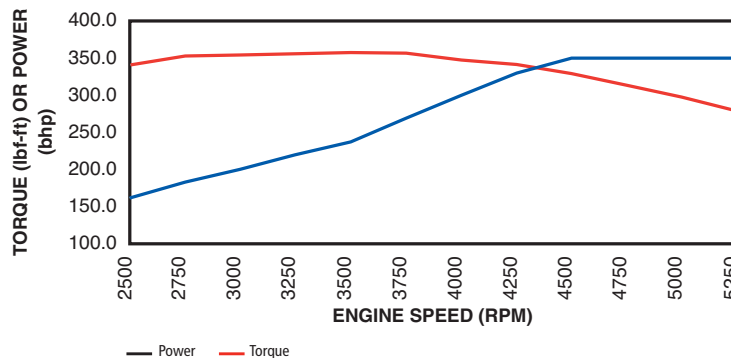

350 HP
357 ft/lbs

SystemAX Recommendations

It's recommended that a 4-bolt main short block be used, although a good 2-bolt main short block can also be used. Minimum cylinder head valve size requirement is 1.94" intake diameter and 1.50" exhaust diameter. Compression requirement is 9.8:1. Holley testing was conducted with a 750 CFM vacuum secondary carburetor, P/N 0-3310. A good set of 1-5/8" tube headers used in conjunction with some high-flow/low back pressure mufflers won't hurt you either. If you're running an automatic transmission a 2,000-2,500 RPM stall converter will help lower drag strip times. New, top quality gaskets for your specific application are required and are not part of the package.

Chevrolet 302, 327, 350 V8 - (1968-86) Part # 300-503-1^(B) 3

Comments/Recommendations

This is a maximum performance carbureted street kit that will really light your fire! A zero-decked block with 4-bolt mains and a forged steel crankshaft will get you started. Top it all off with a set of Hooker or FlowTech headers and a 750 CFM Holley and you'll have what it takes. NOS nitrous, of course, is optional.

Vital Statistics

Engine production years: 1968-86
 Horsepower: 425HP @ 6150 RPM
 Torque: 425 lbs./ft. @ 4250 RPM

Kit Contents

Lunati hydraulic camshaft and lifters, P/N 07104LK
 Holley dual plane aluminum intake manifold, P/N 8150
 Double roller timing chain and gears
 Fully assembled Holley aluminum cylinder heads, P/N 300-552-1
 Hardened push rods, P/N 301-37
 ARP® cylinder head bolts, P/N 301-35
 Assembly lube

Camshaft Specifications

Intake valve gross lift: .488"
 Exhaust valve gross lift: .510"
 Intake valve duration @ .050": 234°
 Exhaust valve duration @ .050": 244°
 Rocker arm ratio: 1.5
 Intake valve lobe centerline: 107°
 Lobe separation: 112°

CHEVROLET SystemeMAX II DYNAMOMETER RESULTS

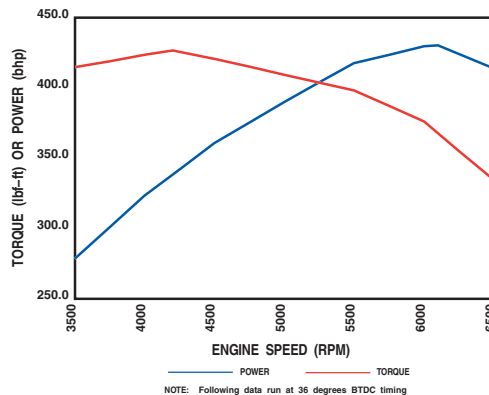

425 HP
425 ft/lbs

SystemeMAX II Recommendations

- Chevrolet 350 CID short block
- 4-bolt Mains
- Zero-Decked
- 10.0:1 Compression Ratio
- Forged Steel Crankshaft
- Autolite Spark Plug: #3934 (race), #3924 (street)



Holley testing used a 750 CFM double pump carburetor, P/N 0-4779S with a set of 1-3/4" Hooker Super Comp tube headers and high-flow, low-back-pressure mufflers. When using a TH-350 then a 3,000+ RPM stall converter will help lower drag strip times. When using a TH-700R4 transmission, a 2,500+ RPM stall converter will perform best. For all-around great street/strip performance a rear axle ratio of around 3.55 should be used. New, top quality gaskets for your specific application are required separately and are not part of the package.

HOW TO CHOOSE A CARB
 STREET CARBURETORS
 SUPERCHARGER CARBURETORS
 RACE CARBURETORS
 MARINE CARBURETORS
 CARB SERVICE PARTS & ACCESSORIES
 FUEL INJECTION
 THROTTLE BODIES
 FUEL PUMPS
 INTAKE MANIFOLDS
 CYLINDER HEADS
 SYSTEMAX
 ENGINE DRESS-UP
 MERCHANDISING
 TECHNICAL INFORMATION
 INDEX

Ford 5.0L H.O. EFI Engine (1986-93) Part # 300-501-1^(B) 

Comments/Recommendations

A maximum performance, but very streetable package for the Ford 5.0L H.O. EFI V8. This one will really let your Mustang kick up its heels! Additional parts recommendations: Holley 70mm Ford throttle body, P/N 112-500; 24 or 30 lb./hr. Holley fuel injectors; Holley 70mm EGR spacer, P/N 112-550; 70mm mass air flow meter; Holley 190 liters per hour in-tank electric fuel pump, P/N 12-901; Holley adjustable fuel pressure regulator, P/N 512-500-1. Add a set of 1-5/8" tube headers (Hooker P/N 6128 or FlowTech P/N 12110), "cat-back" system (Hooker P/N 16862 or FlowTech P/N 42604) and Hooker Aero Chamber mufflers, P/N 21502. **Note:** FlowTech's cat-back system contains mufflers but requires an H-pipe, P/N 53605.

Vital Statistics

1986-93 Ford Mustang, 5.0L H.O. EFI engine
Horsepower: 350HP @ 5750 RPM
Torque: 350 lbs./ft. @ 4000 RPM

Kit Contents

- Lunati roller camshaft, P/N 51027LUN
- Holley upper and lower shiny intake manifold, P/N 300-725
 - (Upper intake manifold only) P/N 300-74S
 - (Lower intake manifold only) P/N 300-75S
- Holley double roller timing chain and gears
- Fully assembled Holley 17° valve aluminum cylinder heads, P/N 300-575
- Hardened push rods, P/N 301-32
- ARP® cylinder head bolts, P/N 301-31

Camshaft Specifications	Intake	Exhaust
Advertised Duration (degrees)	276	280
Duration @ 0.050" (degrees)	221	223
Valve Lift (inches)	0.509	0.509
Lobe Separation Angle (degrees)		112
Opens (degrees)	3.5 BTDC	48.5 BBDC
Closes (degrees)	37.5 ABDC	-5.5 ATDC

SystemAX II Recommendations

A 3.73 axle ratio, for either automatic or manual transmission vehicles, will allow you to take better advantage of the engine's higher RPM torque and horsepower. Spark plug recommended is Autolite P/N 3924.

NOTE ON TRANSMISSIONS: Due to the increased torque and horsepower produced by SystemAX II a heavy duty manual transmission (Ford SVO) must be used. Also, the automatic transmission deserves some attention. One of the Holley engineering test Mustangs used a stock Ford AOD transmission that was modified with a B & M 2500 RPM stall speed torque converter and shift kit. The combination provided very good performance results.

FORD SystemAX II Dynamometer Test Results

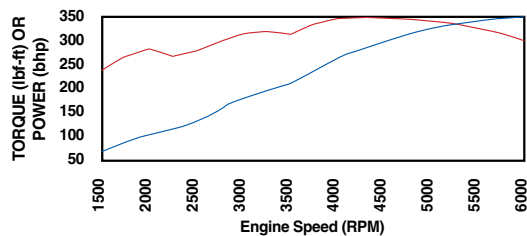

350 HP
350 ft/lbs

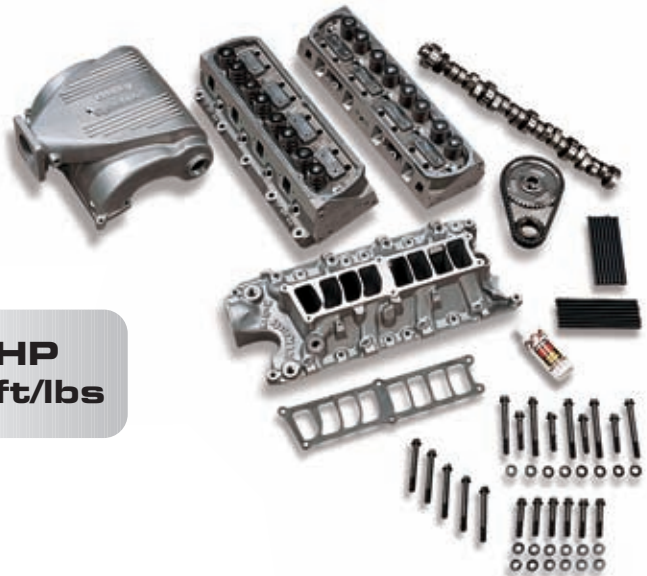

NOTE: Must use Holley 241-81 valve covers, NOS Big Shot, Plate kit or a phenolic spacer for proper manifold to valve cover clearance.

HOW TO CHOOSE A CARB
STREET CARBURETORS
SUPERCARGER CARBURETORS
RACE CARBURETORS
MARINE CARBURETORS
CARB SERVICE PARTS & ACCESSORIES
FUEL INJECTION
THROTTLE BODIES
FUEL PUMPS
INTAKE MANIFOLDS
CYLINDER HEADS
SYSTEMAX
ENGINE DRESS-UP
MERCHANDISING
TECHNICAL INFORMATION
INDEX

HOW TO CHOOSE A CARB
STREET CARBURETORS
SUPERCHARGER CARBURETORS
RACE CARBURETORS
MARINE CARBURETORS
CARB SERVICE PARTS & ACCESSORIES
FUEL INJECTION
THROTTLE BODIES
FUEL PUMPS
INTAKE MANIFOLDS
CYLINDER HEADS
SYSTEMAX
ENGINE DRESS-UP
MERCHANDISING
TECHNICAL INFORMATION
INDEX



301-33

Cylinder Head Installation Kit Part # 301-33

FORD: 5.0L Holley SystemeMAX II Cylinder Heads
Kit contains the necessary compression fitting to lengthen the stock air passage tube that connects to the back side of the heads. Also includes air passage plugs. Necessary whenever installing Holley SystemeMAX II heads.



108-80

Gasket
SystemeMAX II upper and lower manifold. Kormetal gasket used between the Holley SystemeMAX II Ford 5.0L upper and lower manifolds Part # 108-80



301-35

Head Bolt Sets* CHEVY: Small Block Engines . . . Part # 301-35

FORD: 5.0L Engines 1986-93 (7/16" size bolts) Part # 301-31

351 W Engines (1/2" size bolts) Part # 301-36

*The same top quality ARP® (Automotive Racing Products) brand hardened head bolts and washers used in the SystemeMAX II kit.



301-44

Intake Manifold Installation Kit Part # 301-44

Ford SystemeMAX II Upper and Lower Manifold
Kit contains the necessary items needed to install the Holley SystemeMAX II upper and lower manifolds on a 5.0L H.O. engine.
Note: This kit is not required for manifolds manufactured after 2/01/2002 with internal EGR.



Pushrod Set
Chevrolet Small Block V-8
Hardened pushrod set used in the SystemeMAX II kit. Made of 4130 chromoly. 5/16" dia. x 7.894" Part # 301-37
Ford Small Block V-8
Hardened pushrod set used in the SystemeMAX II kit. Made of 4130 chromoly. 5/16" dia. x 6.40" Part # 301-32





ENGINE DRESS-UP

D R E S S - U P 1 5 8 - 1 6 0

Air Cleaners	158
Air Scoops & Service Parts	159
Holley Custom Valve Covers	160
Service Parts & Accessories	160

HOLLEY AIR CLEANERS



120-146

Holley Chrome Round Air Cleaners

Features

- Triple chrome plated
- 14" x 3" & 10" x 2" sizes
- Open element style
- Low restriction
- Traditional look



PART #	DESCRIPTION
120-146 ^(R)	14" air cleaner assembly, fits 5-1/8" neck (w/ POWER SHOT™ filter element)
120-102 ^(R)	14" air cleaner assembly, fits 5-1/8" neck (w/ paper filter element)
120-145 ^(R)	10" air cleaner assembly, fits 5-1/8" neck
220-5 ^(R)	14" x 3" POWER SHOT™ filter element



120-141

Holley Custom Oval Air Cleaner

Features

- Cast aluminum with "Billet" look
- Ball-milled finish
- Fits 5-1/8" airhorn
- Minimal air flow restriction
- Low profile (11.8" x 8.4" x 3.2")
- Very high tech look

PART #	DESCRIPTION
120-141 ^(R)	Air cleaner assembly, fits 5-1/8" neck
120-144 ^(R)	Replacement element



64280

Holley HI TEK Air Cleaner

Features

- Unique low profile design (7.8" x 18.3" x 3")
- Highly polished aluminum
- Includes POWER SHOT™ filters

PART #	DESCRIPTION
64280 ^(R)	Air cleaner assembly
90633 ^(R)	Replacement POWER SHOT™ filter element



120-148

Holley Frē Flo Air Cleaner

Features

- Reusable, washable filter element - no oil required
- Minimal air flow restriction with good filtering
- Low profile for restricted under hood space (2-7/8" H x 11-3/8" W x 8-3/8" L)
- Replacement parts are available separately

PART #	DESCRIPTION
120-148 ^(R)	Air cleaner, fits 5-1/8" neck
120-149 ^(R)	Replacement foam element
1006 ^(R)	Base plate, chrome
1007WIN ^(R)	Top screen, chrome
1009WIN ^(R)	Inner frame
1010WIN ^(R)	Wire clip



120-147

Holley Sure Flo II Air Cleaner

Features

- A natural choice for 2x4 carburetor applications (3-5/16" H x 11-5/16" W x 8-3/8" L)
- Top triple chrome plated
- Replaceable polyester element
- Complete with all hardware and PCV adapter

PART #	DESCRIPTION
120-147 ^(R)	Air cleaner, fits 5-1/8" neck
3009 ^(R)	Replacement element, 2-1/2" tall

HOW TO CHOOSE A CARB
STREET CARBURETORS
SUPERCHARGER CARBURETORS
RACE CARBURETORS
MARINE CARBURETORS
CARB SERVICE PARTS & ACCESSORIES
FUEL INJECTION
THROTTLE BODIES
FUEL PUMPS
INTAKE MANIFOLDS
CYLINDER HEADS
SYSTEMAX
ENGINE DRESS-UP
MERCHANDISING
TECHNICAL INFORMATION
INDEX

Holley Carburetor Air Scoops

- Hilborn or Enderle styles are available
- Cast aluminum casings are highly polished
- Designs are available to fit either 1x4 or 2x4 carburetor installations (5-1/8" necks)
- Bases are adjustable to accommodate 8-1/2" to 10" center-to-center carburetor spacings
- Looks great on a supercharger installation or can be used on carburetor alone
- Includes air cleaner(s)

APPLICATION	PART #
Weiland Hilborn-style (1x4) Dimensions: 13" x 10" x 6"	7220 ^(B) ◆
Weiland Hilborn-style (2x4) Dimensions: 20.5" x 10" x 6"	7221 ^(B) ◆
Weiland Enderle-style (2x4) Dimensions: 20.5" x 13.3" x 4.8"	7223 ^(B) ◆



7221

Carburetor Air Horn Gaskets

APPLICATION	PART #
5" diameter x .060"	108-4
5" diameter x .200"	108-62
7" diameter x .060"	108-73
3x2 carburetors (D-shaped)	108-71



7223

Air Cleaner Spacers

APPLICATION	PART #
5" diameter x 1-3/8" high	17-13
5" diameter x 3/4" high	17-14

Air Cleaner/Air Scoop Filter Elements

APPLICATION	PART #
Replacement filter for Weiland's Enderle- and Hilborn-style air scoops	3010
Replacement filter for Holley MegaScoop air cleaner	93156
Replacement filter for Holley Hi Tek air cleaner	90633



108-4



108-71



17-13



17-14

Hood Scoop Plug

APPLICATION	PART #
Polyurethane foam plug that's designed to fit the most popular hood scoops. Resistant to gasoline.	120-139



93156



3010

Powershot™ Filters

APPLICATION	PART #
Universal - round 14" x 3"	220-5
Universal - round 14" x 4"	220-7
1986-1993 Mustang 5.0L- Panel 11.250" L x 8.875" W x 1.500" H	221-2
1998-2003 Camaro/Firebird - Panel 16.000" L x 8.000" W x 1.000" H	221-4
1996-1997 Camaro SS - Panel 13.500" L x 6.625" W x 1.000" H	221-5

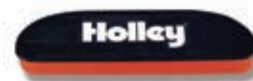

120-139

HOW TO CHOOSE A CARB
STREET CARBURETORS
SUPERCHARGER CARBURETORS
RACE CARBURETORS
MARINE CARBURETORS
CARB SERVICE PARTS & ACCESSORIES
FUEL INJECTION
THROTTLE BODIES
FUEL PUMPS
INTAKE MANIFOLDS
CYLINDER HEADS
SYSTEMAX
ENGINE DRESS-UP
MERCHANDISING
TECHNICAL INFORMATION
INDEX

Holley Custom Valve Covers



241-81



241-80

Application

Chevrolet Engines

Small Block V8 4-bolt - old style - Chrome Stamped Steel-Short **241-80**

Ford Engines

All - Chrome Stamped Steel-Short **241-81***

* Fits with SystemeMAX intake P/N 300-725 and includes oil fill tube and breather cap

Valve Cover Service Parts & Accessories



241-201

Chrome Plated "T" Bar Valve Bolts Part # 241-201

Customize your Holley covers while providing convenient removal without tools. 4 per package, includes studs. 1/4-20 Thread

Grommets

Used on Ford die cast covers Part # 241-215



241-213



241-209

Breather Caps

Universal with tube Part # 241-213

Universal without tube. Part # 241-209



241-218



241-217

Oil Baffles (for Holley / MT valve covers)

1.68 center to center Part # 241-218

MERCHANDISING

MERCHANDISING 162-170

Header Cards & Plan-o-gram	162
Apparel	163-165
Holley Brand Metal Signs	165
Holley Brand Neon Wall Clocks.....	166
Banners	167-169
Service/Tuning Manuals	170
Holley Carburetor Installation & Tuning DVD.....	170

Core Holley® Header Card Part # 36-335



Holley Street Avenger™ Header Card Part # 36-337



Performance Parts Center Plan-o-gram Part # 36-192



The Holley Performance Parts Center is a versatile retail display of the fastest moving Holley performance tuning and service parts. Included in the parts assortment are 59 of the most popular Holley part numbers for needle and seat assemblies, jets, power valves, brackets, floats, gaskets, chokes, diaphragms, pumps, cams, springs, etc. A colorful pegboard and header complete the display. What's more, the complete package is priced less than what the parts would cost if bought individually.

These shirts feature full color artwork on the back and the front chest. Shirts are printed on Hanes Beefy Tees, 100 % cotton & pre-shrunk. Available in sizes from SM-XXXL. When placing an order, replace the "xx" with the size desired. For example, a small Holley retro shirt would be 10005-SMHOL. (Use SM, MD, LG, XL, XXL, XXXL)

Holley Retro T-Shirt - Part # 10000-xxHOL

The Holley retro t-shirt features a traditional rat rod style, chopped and channeled '32 Ford pickup. The truck is outfitted with a full race flathead equipped with lakes headers and a trio of Holley 94 carbs. Halibrand® wheels, dirt track tires and the prerequisite Moon® tank give this truck the attitude and look every hot rodder loves.



Weiland Retro T-Shirt - Part # 10000-xxWND

The Weiland retro t-shirt features a classic front engine fuel dragster powered by a Weiland equipped, blown, and injected HEMI®. You can almost hear the cackle of the Nitro in the flaming zoomies as the pilot readies for his pass. The classic Weiland logos take you back to the good old days with a large dragster print on the back and a pocket sized HEMI® on the front chest.



Hooker Retro T-Shirt - Part # 10148-xxHKR

Features a classic image of a '55 Chevy 2 door post assuming the 1960's gasser pose clapped out with a solid axle, American® Torque Thrust rollers, and M&H Racemasters® on the backside. Powered by a nasty rat motor sporting 2 Holley Double Pumpers® perched atop a Weiland Hi Ram. To wake up the neighbors, it's running Hooker Super Competition equal length fenderwell headers, snaking through the fiberglass flip front end. Up front, you have the classic logo that proudly proclaims how much you love your Hookers.



Earl's Retro T-Shirt - Part # 10001-xxERL

The back of the shirt features a vintage sprint® car complete with knock off wheels, wrapped in Firestone® dirt track tires, and sporting big chrome side pipes. This little number is on its way to the races behind a customized '56 GMC pickup with candy apple scallops, chrome reverse wheels, and a spare mill in the bed. A stack-injected small block is printed on the front of the shirt proudly displaying its Earl's plumbing and Weiland accessories. Classic Earl's logos with that famous "Little Guy" complete the look and let everyone know whose high-performance plumbing you run on your ride.



HOW TO CHOOSE A CARB
STREET CARBURETORS
SUPERCHARGER CARBURETORS
RACE CARBURETORS
MARINE CARBURETORS
CARB SERVICE PARTS & ACCESSORIES
FUEL INJECTION
THROTTLE BODIES
FUEL PUMPS
INTAKE MANIFOLDS
CYLINDER HEADS
SYSTEMAX
ENGINE DRESS-UP
MERCHANDISING
TECHNICAL INFORMATION
INDEX



NEW 75th Anniversary Deuce T-Shirt - Part # 10005-xxHOL

Since its introduction 75 years ago, the '32 Ford has been an icon in the world of hot-rodding. In recognition of the Deuce's place in hot rod history, Holley had Chris Froggett whip up a baker's dozen of the most recognizable Deuce hot rods of all time. Printed in full color on a white Hanes Beefy T, the large print on the back pays homage to some of our favorite Deuces down through the ages.



NEW Weiland Belly Tanker Retro T-Shirt - Part # 10002-xxWND

Flashback to Bonneville, 1955...legendary Tom Beatty pushes his supercharged flathead powered belly tanker equipped with Weiland Power and Speed parts to an astounding two-way average of 211.144 mph. Famed artist Chris Froggett vividly captures the action in his classic style on the latest Retro Series T-shirt. In addition to the large print on the back, Weiland's historic "Power and Speed" logo adorns the front chest area of the navy blue, high quality Hanes Beefy-T shirt.



NEW NOS Bottle Rocket T-shirt - Part # 19070-xxNOS

Do you dig hot bikes, hotter women and NOS? With the latest T-design from NOS, you get all three! The new NOS "T" features original artwork by Chris Froggett and comes alive in vivid colors on a black Hanes Beefy T. The large print on the back depicts an NOS equipped Suzuki Hayabusa getting ready to make another pass by the sexy umbrella girl, NOS Nikki. The small front pocket artwork again showcases Nikki's fantasy of taking a midnight ride to the moon on the NOS Express Rocket.



NEW Holley Rebirth of an American Icon T-shirt - Part # 10006-xxHOL

American Icons! Holley and Camaro are two of the biggest names in performance and racing, and both have played a major role in automotive performance history. Celebrate the re-birth of the Camaro with this special edition T-Shirt from Holley. The back features Chris Froggett artwork showcasing the new Camaro with a 1969 Camaro cleverly mirrored in the pavement below on a navy blue Hanes Beefy-T T-Shirt. On the front, modern and vintage Holley logos show everyone that you're serious about automotive performance!

Holley Since 1903 Hooded Sweatshirt
Part # 10002-xxHOL

Hooded sweatshirt in gray preshrunk fleece. Front pocket and drawstring hood. Available in sizes SM-3XL



Holley Since 1903 T-shirt
Part # 10001-xxHOL

100% preshrunk t-shirt in gray, with the Holley logo screened in two colors. Available in sizes SM-3XL



NEW Holley Caps



Part # 10007HOL



Part # 10008HOL



Part # 10009HOL

Holley Brand Metal Signs

Designed to dress up your garage, shop or office in a cool way! They're the perfect item for die-hard enthusiasts.

Key Features & Benefits

- New metal signs for retail locations, garage or office
- Great gift idea
- High shine embossing
- Die cut for "one of a kind" look
- Earl's sign features the current logo & popular Earl's mascot
- Flowtech sign introduces its brand new logo!
- Holley Retro signs blasts you into the past with the world's most famous performance brand
- Hooker sign is all fired up with its classic logo & zoomie headers
- NOS Refill blends classic with current power
- NOS sign heats up any wall & tells you sell the #1 brand in nitrous
- Weiland Retro sign takes another look at a classic logo & Weiland's rich history

Part #	Description	Size
10000ERL	Earl's metal sign	24" x 8.25"
10000FLT	Flowtech metal sign	18" x 7"
10003HOL	Holley Retro metal sign	18" x 18"
10145HKR	Hooker metal sign	12" x 19"
19326NOS	NOS Refill metal sign	9" x 17"
19327NOS	NOS metal sign	24" x 14"
10001WND	Weiland Retro metal sign	20" x 20"



HOW TO CHOOSE A CARB STREET CARBURETORS SUPERCHARGER CARBURETORS RACE CARBURETORS MARINE CARBURETORS CAR SERVICE PARTS & ACCESSORIES FUEL INJECTION THROTTLE BODIES FUEL PUMPS INTAKE MANIFOLDS CYLINDER HEADS SYSTEMAX ENGINE DRESS-UP MERCHANDISING TECHNICAL INFORMATION INDEX

HOW TO CHOOSE A CARB
STREET CARBURETORS
SUPERCHARGER CARBURETORS
RACE CARBURETORS
MARINE CARBURETORS
CARB SERVICE PARTS & ACCESSORIES
FUEL INJECTION
THROTTLE BODIES
FUEL PUMPS
INTAKE MANIFOLDS
CYLINDER HEADS
ENGINE DRESS-UP
MERCHANDISING
TECHNICAL INFORMATION
INDEX

Holley Brand Neon Wall Clocks



Part #	Description
11000ERL	Earl's - yellow neon, chrome hands w/ black second hand
10004HOL	Holley - blue neon, chrome hands w/ black second hand
10150HKR	Hooker - red neon, chrome hands w/ gray second hand
19352NOS	NOS - blue neon, red hands w/ black second hand
10005WND	Weiland - blue neon, off-white hands w/ red second hand

Holley has done it again! Six new wall clocks bring the biggest names in speed parts to life through the use of neon! Our popular nostalgic art, drawn by renowned artist Chris Froggett, was used on the Weiland and Earl's clocks. The blue and red "Holley High Performance Carburetion" logo made famous by NASCAR® racers in the 1960s was used on the Holley clock. Our latest "zoomie" version of the world famous Hooker Header logo was used on the Hooker clock while the already popular NOS gauge clock art was used again on the NOS neon clock. The clock faces are surrounded by brightly beveled rims with a chrome finish. They measure 14.5" outside diameter and the neon is powered by a UL listed 12 volt AC adapter with a 6' cord. The clock mechanism requires one AA battery (not included).



Holley Brand Decal Sheet

Part # 36-325



Holley Carb Store™

Part # 36-176

Treat your carburetor to some TLC with this handy, yet practical carburetor carrying case. Made of durable plastic, it is designed to securely hold and protect your carburetor during storage or transportation. There's even room enough to accommodate a dual feed fuel line, so it need not be disconnected from the carburetor. A neat carrying handle rounds out the package and adds convenience. Locking tabs promote security. This case can hold a Holley model 2300 carburetor or any of the square flange four barrels.

Holley Family Banner Part # 36-277

Hang this vinyl banner in your garage and let everyone know who you turn to for performance. The background checkerboard designs feature the Holley Equipped logo, followed by color logos of all of our brands. (measures 2' x 9').



Holley #1 In Fuel Systems Banner Part # 36-33

This banner features the Holley logo, and is designed with 4 corner grommets and full four-side stitched hems for strength. (measures 2' x 8').



Holley Carburetors Banner Part # 36-75

This banner features the Holley logo, and is designed with 4 corner grommets and full four-side stitched hems for strength. (measures 2' X 8').



Holley Fuel Pumps Banner Part # 36-194

This banner features the Holley logo, and is designed with 4 corner grommets and full four-side stitched hems for strength. (measures 2' X 8').



NOS Nitrous Banner Part # 19306NOS

How fast is your car? Hang this bright orange NOS banner and tell everyone that you're NOS-powered! Features corner grommets for easy hanging (measures 3' x 5').

**Hooker Authorized Speed Shop Banner** Part # 36-363

Make Hooker Headers the focus of your garage with our graphic color banner. Designed with 4 corner grommets for easy hanging (measures 2' by 4').

**Earl's Banner** Part # 36-75

Hang this vinyl Earl's banner in your garage and let everyone know who you turn to for performance plumbing. Price includes shipping and handling (measures 18" x 36").

**NOS Energy Drink Banner** Part # 36-351

How fast is your life? Hang this bright orange NOS high octane energy drink banner and tell everyone that you're NOS-powered! Features corner grommets for easy hanging (measures 3' x 6').



Weiland Intake Manifolds Banner Part # 36-270

The manifold's in your car, so put the banner on your wall! Weiland's banner is made from heavy nylon, with reinforced stitched hems on all four sides (measures 2' x 8').



Flowtech Exhaust, Punish The Pavement Banner Part # 36-373

Hang this vinyl Flowtech banner in your garage and let everyone know who you turn to for performance exhaust (measures 30" x 90").



HOW TO CHOOSE A CARB STREET CARBURETORS SUPERCHARGER CARBURETORS RACE CARBURETORS MARINE CARBURETORS CARB SERVICE PARTS & ACCESSORIES FUEL INJECTION THROTTLE BODIES FUEL PUMPS INTAKE MANIFOLDS CYLINDER HEADS SYSTEMAX ENGINE DRESS-UP

MERCHANDISING TECHNICAL INFORMATION INDEX

HOW TO CHOOSE A CARB
STREET CARBURETORS
SUPERCHARGER CARBURETORS
RACE CARBURETORS
MARINE CARBURETORS
CARB SERVICE PARTS & ACCESSORIES
FUEL INJECTION
THROTTLE BODIES
FUEL PUMPS
INTAKE MANIFOLDS
CYLINDER HEADS
ENGINE DRESS-UP
MERCHANDISING
TECHNICAL INFORMATION
INDEX

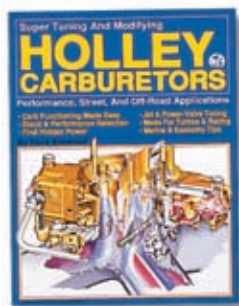

36-136

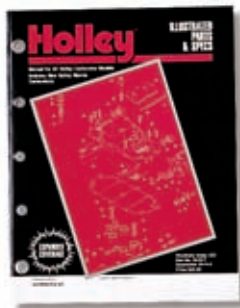

36-51-7

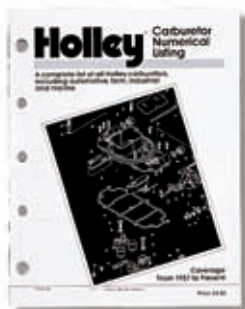

36-168

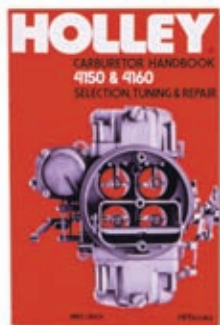

36-133

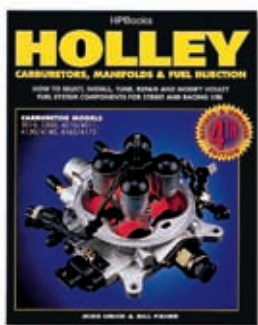

36-73

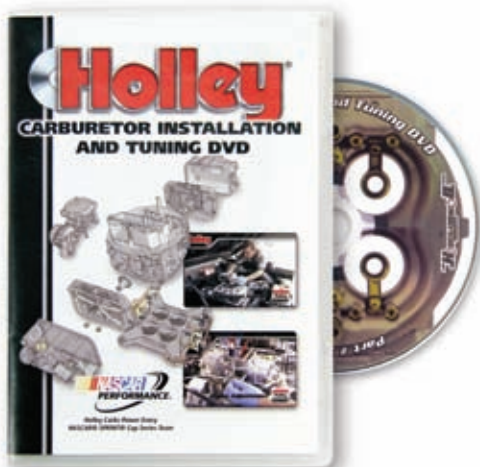

Learn More About Holley Fuel System Products!

•Tuning • Modifications • Selection • Servicing

Holley Carburetors Manual Part# 36-136

By Dave Emanuel. A detailed comprehensive guide to proper selection and modification of Holley carburetors for competition. Includes turbocharging modifications. Tips on rebuilding Holley two and four barrel models. Illustrated. 128 pages.

Illustrated Parts & Specs Manual Part# 36-51-7

A technical aid showing exploded illustrations of current Holley carburetor models. Complete list of parts and adjustment specifications. Designed for the professional service technician.

Holley Carburetors, Manifolds & Fuel Injection Part# 36-73

By Bill Fisher and Mike Urich. New for 1994. Covers all 2010, 2300, 4010/4011, 4150/4160/4180, 4165/4175 and 4500 performance carburetors. Includes Holley Pro-Jection 1-bbl. through 4-bbl. models with installation and tuning information not found in any other publication. Explains how to select and install the "right" carburetor and manifold. Plus alcohol modifications for short track racing. 224 pages.

Holley Carburetor Numerical Listing Part# 36-168

Contains a complete list of all Holley carburetors, including automotive, farm, industrial and marine along with their corresponding repair kits. The listing consists of over 3,500 applications covering vehicles from 1957 to the present.

Holley Model 4150 & 4160 Carburetor Handbook Part# 36-133

By M. Urich. Includes application recommendations, tuning and repair.



Holley Carburetor Installation & Tuning DVD Part# 36-381

Two hours of everything you ever wanted to know about Holley carburetors! Virtual tours, exploded views, step-by-step under the hood installation including transmission kickdowns, advanced tuning, & troubleshooting. It is interactive, so you can easily find the chapters you need.

Holley Carburetor Installation & Tuning DVD Zip Mailer Part# 36-378

Holley Technical Service



Holley Technical Service offers the performance enthusiast an opportunity to talk to a factory-trained technician in the areas of:

- Product Application & System Recommendations
- Specifications
- Troubleshooting
- Installation Tips
- Performance Tuning

Visit Holley's web site at: www.holley.com

CONTACT

Holley, Hooker, NOS, Weiand & Flowtech Technical Service at:

Telephone: 1-270-781-9741 or 1-866-GOHOLLEY

FAX: 1-270-781-9772

Earl's Technical Service at:

Telephone: 1-310-609-1602

E-MAIL

Go to www.holley.com then click on Tech Service Link

WRITE

Holley Performance Products
 Technical Service
 P.O. Box 10360
 Bowling Green, KY 42102



HolleyTV.com

Featuring:

- Tech Segments with Chuck Hanson
- Holley Carburetor Tuning and Installation Videos
- In Depth Product Interviews On New and Hot Products From Holley
- Product Testimonials and Interviews With Racers and Consumers
- Dyno & Track Testing

HOW TO CHOOSE A CARB
 STREET CARBURETORS
 SUPERCHARGER CARBURETORS
 RACE CARBURETORS
 MARINE CARBURETORS
 CARB SERVICE PARTS & ACCESSORIES
 FUEL INJECTION
 THROTTLE BODIES
 FUEL PUMPS
 INTAKE MANIFOLDS
 CYLINDER HEADS
 SYSTEMMAX
 ENGINE DRESS-UP
 MERCHANDISING
 TECHNICAL INFORMATION
 INDEX

HOW TO CHOOSE A CARB	Carburetor Part No.	Carb. Model No.	CFM	Renew Kit	Trick Kit	Needle & Seal	Primary Main Jet	Secondary Main Jet or Plate	Primary Metering Block	Secondary Metering Block	Power Valve	Pump Nozzle Size, Primary
STREET CARBURETORS	R1848-1	4160	465	37-119	37-933	6-506	122-57	N/S	N/S	34R9716-3	125-85	0.025
STREET CARBURETORS	R1849	4160	550	37-119	37-933	6-506	122-62	N/S	N/S	N/S	125-85	0.025
STREET CARBURETORS	R1850-2	4160	600	37-119	37-933	6-506	122-66	134-9	134-128	134-9	125-65	0.025
STREET CARBURETORS	R1850-3	4160	600	37-119	37-933	6-506	122-66	134-9	134-128	134-9	125-65	0.025
STREET CARBURETORS	R1850-4	4160	600	37-119	37-933	6-506	122-66	134-9	134-128	134-9	125-65	0.031
SUPERCARGER CARBURETORS	R1850-5	4160	600	37-119	37-933	6-506	122-66	134-9	134-128S	134-9	125-65	0.031
SUPERCARGER CARBURETORS	R1850-6	4160	600	37-119	37-933	6-506	122-66	134-9	134-128	134-9	125-65	0.031
SUPERCARGER CARBURETORS	R1850-7	4160	600	37-119	37-933	6-506	122-64	134-9	N/A	134-9	125-65	0.031
SUPERCARGER CARBURETORS	R1850-8	4160	600	37-119	37-933	6-506	122-64	134-9	N/A	134-9	125-65	0.031
SUPERCARGER CARBURETORS	R1850-9	4160	600	37-119	37-933	6-511	122-64	134-9	N/A	134-9	125-65	0.031
SUPERCARGER CARBURETORS	R1850-10	4160	600	37-119	37-933	6-511	122-64	134-9	N/A	134-9	125-65	0.031
RACE CARBURETORS	R2818-1	4150	600	37-1537	37-933	6-506	122-65	122-76	N/A	N/S	125-65	0.025
RACE CARBURETORS	R3124	4150	750	37-1539	37-933	6-504	122-70	122-76	N/S	N/S	125-85 (12)	0.025
RACE CARBURETORS	R3247	4150	780	37-1539	37-933	6-504	122-70	122-76	N/S	N/S	125-85 (12)	0.021
RACE CARBURETORS	R3259-1	4150	725	N/A	N/A	N/S	122-68	122-78	N/S	N/S	125-85	0.025
MARINE CARBURETORS	R3310-1	4150	780	37-1539	37-933	6-504	122-72	122-76	134-131	N/S	"(12,13)"	0.025
MARINE CARBURETORS	R3310-2	4160	750	37-754	37-933	6-504	122-72	134-21	134-131	134-21	125-65	0.025
MARINE CARBURETORS	R3310-3	4160	750	37-754	37-933	6-504	122-72	134-21	134-131	134-21	125-65	0.025
MARINE CARBURETORS	R3310-4	4160	750	37-754	37-933	6-504	122-72	134-21	134-131	134-21	125-65	0.031
MARINE CARBURETORS	R3310-5	4160	750	37-754	37-933	6-504	122-72	134-21	134-131	134-21	125-65	0.031
MARINE CARBURETORS	R3310-6	4160	750	37-754	37-933	6-504	122-72	134-21	134-131	134-21	125-65	0.031
MARINE CARBURETORS	R3310-7	4160	750	37-754	37-933	6-504	122-72	134-21	134-131	134-21	125-65	0.031
MARINE CARBURETORS	R3310-8	4160	750	37-754	37-933	6-504	122-72	134-21	134-131	134-21	125-65	0.031
MARINE CARBURETORS	R3310-9	4160	750	37-754	37-933	6-504	122-72	134-21	134-131	134-21	125-65	0.031
MARINE CARBURETORS	R3310-10	4160	750	37-754	37-933	6-504	122-70	134-21	N/A	134-21	125-65	0.031
MARINE CARBURETORS	R3310-11	4160	750	37-754	37-933	6-504	122-70	134-21	N/A	134-21	125-65	0.031
CARB SERVICE PARTS & ACCESSORIES	R3367	4160	585	37-119	37-933	N/S	122-65	34R9716-22	N/S	N/R	125-65	0.025
CARB SERVICE PARTS & ACCESSORIES	R3370	4160	585	37-119	37-933	6-504	122-65	N/S	N/S	N/R	125-65	0.025
CARB SERVICE PARTS & ACCESSORIES	R3418-1	4150	855	37-1539	37-933	6-504	78C/82T	82C/80T	N/S	N/S	(15,21)	0.028
CARB SERVICE PARTS & ACCESSORIES	R3613	4150	770	37-1539	37-933	6-504	122-71	122-76	N/S	N/S	125-85 (12)	0.021
FUEL INJECTION	R3659	2300	466	37-1537	37-933	6-504	N/R	N/S	N/R	N/S	N/R	N/R
FUEL INJECTION	R3660	2300	350	37-1537	37-933	6-504	122-64	N/R	N/S	N/R	125-65	0.021
FUEL INJECTION	R3807	4150	595	37-1537	37-933	N/S	122-67	122-72	N/S	N/S	125-65	0.025
FUEL INJECTION	R3810	4160	585	37-1537	37-933	N/S	122-65	34R9716-22	N/S	N/R	125-65	0.025
FUEL INJECTION	R3811	4160	585	37-1537	37-933	N/S	122-65	N/S	N/S	N/R	125-65	0.025
FUEL PUMPS	R3910	4150	780	37-1539	37-933	6-504	122-71	122-76	N/S	N/S	125-65 (12)	0.021
FUEL PUMPS	R4053	4150	780	37-1539	37-933	6-504	122-68	122-76	N/S	N/S	125-65 (12)	0.025
THROTTLE BODIES	R4055-1	2300	350	37-1537	37-933	6-504	122-63	N/R	N/S	N/R	125-65	0.021
THROTTLE BODIES	R4056-1	2300	350	37-1537	37-933	6-504	122-61	N/R	N/S	N/R	125-65	0.025
THROTTLE BODIES	R4118	4150	725	37-1539	37-933	6-504	122-68	122-78	N/S	N/S	125-85	0.025
THROTTLE BODIES	R4144-1	2300	350	37-1537	37-933	6-504	122-62	N/R	N/S	N/R	125-65	0.031
INTAKE MANIFOLDS	R4224	4160	660	37-1537	37-933	6-508	122-76	34R9716-12	N/A	34R9716-12	N/R	0.025
INTAKE MANIFOLDS	R4235	4160	770	37-485	37-933	6-504	75/80	N/S	N/S	N/R	125-65	0.035
INTAKE MANIFOLDS	R4236	4160	770	37-485	37-933	6-504	122-80	N/S	N/S	N/R	125-65	0.035
INTAKE MANIFOLDS	R4295	4150	585	37-485	37-933	6-504	122-69	122-71	N/S	N/S	125-65	0.025
CYLINDER HEADS	R4296	4150	850	37-485	37-933	6-504	78C/82T	82C/80T	N/S	N/S	125-65 (15)	0.035
CYLINDER HEADS	R4346	4150	780	37-1539	37-933	6-504	122-68	122-76	N/S	N/S	125-85 (12)	0.025
CYLINDER HEADS	R4365-1	2300	500	37-1537	37-933	6-504	N/R	N/S	N/R	N/R	N/R	N/R
CYLINDER HEADS	R4412	2300	500	37-474	37-933	6-504	122-73	N/R	134-137	N/R	125-50	0.028
CYLINDER HEADS	R4412-1	2300	500	37-474	37-933	6-504	122-73	N/R	134-137	N/R	125-50	0.028
CYLINDER HEADS	R4412-2	2300	500	37-474	37-933	6-504	122-73	N/R	134-137	N/R	125-50	0.028
CYLINDER HEADS	R4412-3	2300	500	37-474	37-933	6-504	122-73	N/R	134-137	N/R	125-50	0.028
CYLINDER HEADS	R4412-4	2300	500	37-474	37-933	6-504	122-73	N/R	134-137	N/R	125-50	0.028
CYLINDER HEADS	R4412-5	2300	500	37-474	37-933	6-504	122-73	N/R	134-137	N/R	125-50	0.028
SYSTEMAX	R4452-1	4160	600	37-119	37-933	6-506	122-63	134-39	N/S	N/S	125-85	0.031
ENGINE DRESS-UP	R4490	4150	780	37-1539	37-933	6-504	122-70	122-76	N/S	N/S	125-85 (12)	0.025
ENGINE DRESS-UP	R4514-1	4150	700	37-1537	37-933	6-504	122-66	122-79	N/S	N/S	125-65	0.029
ENGINE DRESS-UP	R4548	4160	450	37-119	37-933	6-506	122-57	N/S	N/S	N/S	N/S	0.031

See pages 190 & 191 for numerical listing specific footnotes.

Secondary Nozzle Size or Spring Color	Primary Bowl Gasket ¹	Primary Metering Block Gasket	Secondary Bowl Gasket	Secondary Metering Block Gasket	Secondary Metering Plate Gasket	Primary Fuel Bowl	Secondary Fuel Bowl	Throttle Body & Shaft Assembly	Venturii Diameter Primary	Venturii Diameter Secondary	Throttle Bore Diameter Primary	Throttle Bore Diameter Secondary
Green	108-83-2	108-89-2	108-90-2	108-90-2	108-27-2	34R2456A	134-105	N/S	1-3/32	1-3/32	1-1/2	1-1/2
Plain	108-83-2	108-89-2	108-90-2	108-90-2	108-27-2	34R2456A	134-105	N/S	1-3/16	1-1/4	1-1/2	1-1/2
Plain	108-83-2	108-89-2	108-90-2	108-90-2	108-27-2	134-101	134-105	112-20	1-1/4	1-5/16	1-9/16	1-9/16
Plain	108-83-2	108-89-2	108-90-2	108-90-2	N/R	134-101	134-105	112-20	1-1/4	1-5/16	1-9/16	1-9/16
Plain	108-83-2	108-89-2	108-90-2	108-90-2	N/R	134-101	134-105	112-20	1-1/4	1-5/16	1-9/16	1-9/16
Plain	108-83-2	108-89-2	108-90-2	108-90-2	N/R	134-101S	134-105S	112-20	1-1/4	1-5/16	1-9/16	1-9/16
Plain	108-83-2	108-89-2	108-90-2	108-90-2	N/R	134-101	134-105	112-20	1-1/4	1-5/16	1-9/16	1-9/16
Plain	108-83-2	108-89-2	108-90-2	108-90-2	N/R	134-101S	134-105S	112-20	1-1/4	1-5/16	1-9/16	1-9/16
Plain	108-83-2	108-89-2	108-90-2	108-90-2	N/R	134-101	134-105	112-20	1-1/4	1-5/16	1-9/16	1-9/16
Plain	108-83-2	108-89-2	108-90-2	108-90-2	N/R	134-281S	134-282S	112-20	1-1/4	1-5/16	1-9/16	1-9/16
Plain	108-83-2	108-89-2	108-90-2	108-90-2	N/R	134-281S	134-282S	112-112	1-1/4	1-5/16	1-9/16	1-9/16
Purple	108-83-2	108-89-2	108-83-2	108-89-2	N/R	134-101	N/A	N/S	1-1/4	1-5/16	1-9/16	1-9/16
Yellow	108-83-2	108-89-2	108-83-2	108-89-2	N/R	N/S	N/S	N/S	1-3/8	1-7/16	1-11/16	1-11/16
Yellow	108-83-2	108-89-2	108-83-2	108-89-2	N/R	N/S	134-102	N/S	1-3/8	1-7/16	1-11/16	1-11/16
Yellow	108-83-2	108-89-2	108-83-2	108-89-2	N/R	N/S	N/S	N/S	1-5/16	1-3/8	1-11/16	1-11/16
Plain	108-83-2	108-89-2	108-83-2	108-89-2	N/R	134-103	134-102	112-9	1-3/8	1-7/16	1-11/16	1-11/16
Plain	108-83-2	108-89-2	108-90-2	108-90-2	108-27-2	134-103	134-102	112-9	1-3/8	1-7/16	1-11/16	1-11/16
Plain	108-83-2	108-89-2	108-90-2	108-90-2	108-27-2	134-103	134-102	112-9	1-3/8	1-7/16	1-11/16	1-11/16
Plain	108-83-2	108-89-2	108-90-2	108-90-2	108-27-2	134-103	134-102	112-9	1-3/8	1-7/16	1-11/16	1-11/16
Plain	108-83-2	108-89-2	108-90-2	108-90-2	108-27-2	134-103S	134-102S	N/A	1-3/8	1-7/16	1-11/16	1-11/16
Plain	108-83-2	108-89-2	108-90-2	108-90-2	108-27-2	134-103S	134-102S	N/A	1-3/8	1-7/16	1-11/16	1-11/16
Plain	108-83-2	108-89-2	108-90-2	108-90-2	108-27-2	134-103	134-102	N/A	1-3/8	1-7/16	1-11/16	1-11/16
Plain	108-83-2	108-89-2	108-90-2	108-90-2	108-27-2	134-103	134-102	N/A	1-3/8	1-7/16	1-11/16	1-11/16
Plain	108-83-2	108-89-2	108-90-2	108-90-2	108-27-2	134-103	134-102	N/A	1-3/8	1-7/16	1-11/16	1-11/16
Plain	108-83-2	108-89-2	108-90-2	108-90-2	108-27-2	134-103	134-102	112-117	1-3/8	1-7/16	1-11/16	1-11/16
Purple	108-83-2	108-89-2	108-90-2	108-90-2	108-27-2	N/S	134-105	N/S	1-1/4	1-5/16	1-9/16	1-9/16
Purple	108-83-2	108-89-2	108-90-2	108-90-2	108-27-2	N/S	134-105	N/S	1-1/4	1-5/16	1-9/16	1-9/16
Yellow	108-83-2	108-89-2	108-83-2	108-89-2	N/R	134-103	N/S	N/S	1-9/16	1-9/16	1-3/4	1-3/4
Yellow	108-83-2	108-89-2	108-83-2	108-89-2	N/R	N/S	N/S	N/S	1-3/8	1-7/16	1-11/16	1-11/16
Brown	N/R	N/R	108-90-2	108-90-2	108-27-2	N/R	N/S	N/S	1-3/8	N/A	1-3/4	N/A
N/R	108-83-2	108-89-2	N/R	N/R	N/R	N/S	N/R	N/S	1-3/16	N/A	1-1/2	N/A
Purple	108-83-2	108-89-2	108-83-2	108-89-2	N/R	N/S	N/S	N/S	1-1/4	1-5/16	1-9/16	1-9/16
Purple	108-83-2	108-89-2	108-90-2	108-90-2	108-27-2	N/S	N/S	N/S	1-1/4	1-5/16	1-9/16	1-9/16
Purple	108-83-2	108-89-2	108-90-2	108-90-2	108-27-2	N/S	N/S	N/S	1-1/4	1-5/16	1-9/16	1-9/16
Yellow	108-83-2	108-89-2	108-83-2	108-89-2	N/R	134-103	N/S	N/S	1-3/8	1-7/16	1-11/16	1-11/16
Yellow	108-83-2	108-89-2	108-83-2	108-89-2	N/R	134-103	N/S	N/S	1-3/8	1-7/16	1-11/16	1-11/16
N/R	108-83-2	108-89-2	N/R	N/R	N/R	N/S	N/R	N/S	1-3/16	N/A	1-1/2	N/A
N/R	108-83-2	108-89-2	N/R	N/R	N/R	N/S	N/R	N/S	1-3/16	N/A	1-1/2	N/A
Yellow	108-83-2	108-89-2	108-83-2	108-89-2	N/R	134-103	134-102	N/S	1-5/16	1-3/8	1-11/16	1-11/16
N/R	108-83-2	108-89-2	N/R	N/R	N/R	N/S	N/R	N/S	1-3/16	N/A	1-1/2	N/A
0.025	108-83-2	108-89-2	108-90-2	108-90-2	108-27-2	134-101	N/A	N/A	1-1/4	1-5/16	1-11/16	1-11/16
Plain	108-83-2	108-89-2	108-90-2	108-90-2	108-27-2	134-101	N/A	N/S	1-3/8	1-7/16	1-11/16	1-11/16
Plain	108-83-2	108-89-2	108-90-2	108-90-2	108-27-2	134-101	N/A	N/S	1-3/8	1-7/16	1-11/16	1-11/16
0.025	108-83-2	108-89-2	108-83-2	108-89-2	N/R	N/S	N/S	N/S	1-1/4	1-5/16	1-9/16	1-9/16
0.035	108-83-2	108-89-2	108-83-2	108-89-2	N/R	134-103	N/S	N/S	1-9/16	1-9/16	1-3/4	1-3/4
Yellow	108-83-2	108-89-2	108-83-2	108-89-2	N/R	N/S	N/S	N/S	1-3/8	1-7/16	1-11/16	1-11/16
Yellow	N/R	N/R	108-90-2	108-90-2	108-13-2	N/S	N/S	N/S	1-9/16	N/A	1-3/4	N/A
N/R	108-83-2	108-89-2	N/R	N/R	N/R	134-103	N/R	112-2	1-3/8	N/R	1-11/16	N/R
N/R	108-83-2	108-89-2	N/R	N/R	N/R	134-103	N/R	112-2	1-3/8	N/R	1-11/16	N/R
N/R	108-83-2	108-89-2	N/R	N/R	N/R	134-103	N/R	112-2	1-3/8	N/R	1-11/16	N/R
N/R	108-83-2	108-89-2	N/R	N/R	N/R	134-103S	N/R	112-2	1-3/8	N/R	1-11/16	N/R
N/R	108-83-2	108-89-2	N/R	N/R	N/R	134-103	N/R	112-2	1-3/8	N/R	1-11/16	N/R
N/R	108-83-2	108-89-2	N/R	N/R	N/R	134-103	N/R	112-2	1-3/8	N/R	1-11/16	N/R
Purple	108-83-2	108-89-2	108-90-2	108-90-2	108-27-2	N/A	134-105	N/S	1-1/4	1-5/16	1-9/16	1-9/16
Yellow	108-83-2	108-89-2	108-83-2	108-89-2	N/R	134-103	N/S	N/S	1-3/8	1-7/16	1-11/16	1-11/16
Yellow	108-83-2	108-89-2	108-83-2	108-89-2	N/R	N/S	N/S	N/S	1-3/8	1-7/16	1-11/16	1-11/16
Brown	108-83-2	108-89-2	108-90-2	108-90-2	108-27-2	N/A	134-105	N/S	1-3/32	1-3/32	1-1/2	1-1/2

See pages 190 & 191 for numerical listing specific footnotes.

HOW TO CHOOSE A CARB
STREET CARBURETORS
SUPERCHARGER CARBURETORS
RACE CARBURETORS
MARINE CARBURETORS
CARB SERVICE PARTS & ACCESSORIES
FUEL INJECTION
THROTTLE BODIES
FUEL PUMPS
INTAKE MANIFOLDS
CYLINDER HEADS
SYSTEMAX
ENGINE DRESS-UP
MERCHANDISING
TECHNICAL INFORMATION
INDEX

174 TECHNICAL INFORMATION - Carburetor Numerical Listing

HOW TO CHOOSE A CARB	Carburetor Part No.	Carb. Model No.	CFM	Renew Kit	Trick Kit	Needle & Seal	Primary Main Jet	Secondary Main Jet or Plate	Primary Metering Block	Secondary Metering Block	Power Valve	Pump Nozzle Size, Primary
STREET CARBURETORS	R4555	4150	780	37-1539	37-933	6-504	122-70	122-76	N/S	N/S	125-85 (12)	0.025
STREET CARBURETORS	R4575	4500	1050	37-1539	37-933	6-504	122-84	122-84	N/S	N/S	125-65 (15)	0.035
STREET CARBURETORS	R4609	4150	730	37-1537	37-933	6-504	122-66	122-79	N/S	N/S	125-65	0.029
STREET CARBURETORS	R4628	4150	780	37-1537	37-933	6-504	122-70	122-83	N/S	N/S	125-85	0.026
STREET CARBURETORS	R4647	4150	735	37-1537	37-933	6-504	122-64	122-82	N/S	N/S	125-85	0.031
SUPERCARGER CARBURETORS	R4653	4150	780	37-1537	37-933	6-504	122-71	122-82	N/S	N/S	125-65	0.026
SUPERCARGER CARBURETORS	R4670	2300	350	37-1537	37-933	6-504	122-62	N/R	N/S	N/R	125-65	0.031
SUPERCARGER CARBURETORS	R4672	2300	500	37-1537	37-933	6-504	N/R	N/S	N/R	N/R	N/R	N/R
SUPERCARGER CARBURETORS	R4691-2	2110	300	N/A	N/A	N/S	122-63	N/R	N/R	N/R	N/R	0.021
SUPERCARGER CARBURETORS	R4742	4150	600	37-1539	37-933	6-504	122-63	122-72	N/S	N/S	N/S	0.031
RACE CARBURETORS	R4776	4150	600	37-485	37-933	6-504	122-69	122-71	N/S	N/A	125-65	0.025
RACE CARBURETORS	R4776-1	4150	600	37-485	37-933	6-504	122-66	122-76	N/S	N/A	125-65	0.028
RACE CARBURETORS	R4776-2	4150	600	37-485	37-933	6-504	122-66	122-76	N/A	N/A	125-65	0.028
RACE CARBURETORS	R4776-3	4150	600	37-485	37-933	6-504	122-66	122-73	N/A	N/A	125-65	0.028
RACE CARBURETORS	R4776-4	4150	600	37-485	37-933	6-504	122-66	122-73	N/A	N/A	125-65	0.028
RACE CARBURETORS	R4776-5	4150	600	37-485	37-933	6-504	122-66	122-73	N/A	N/A	125-65	0.028
RACE CARBURETORS	R4776-6	4150	600	37-485	37-933	6-504	122-66	122-73	N/A	N/A	125-65	0.028
RACE CARBURETORS	R4776-7	4150	600	37-485	37-933	6-504	122-66	122-73	134-63	134-64	125-65	0.028
RACE CARBURETORS	R4777	4150	650	37-485	37-933	6-504	122-71	122-76	N/S	N/A	125-65	0.025
RACE CARBURETORS	R4777-1	4150	650	37-485	37-933	6-504	122-67	122-76	N/S	N/A	125-65	0.028
RACE CARBURETORS	R4777-2	4150	650	37-485	37-933	6-504	122-67	122-76	134-150	N/A	125-65	0.028
RACE CARBURETORS	R4777-3	4150	650	37-485	37-933	6-504	122-67	122-73	134-150	N/A	125-65	0.028
RACE CARBURETORS	R4777-4	4150	650	37-485	37-933	6-504	122-67	122-73	134-150	N/A	125-65	0.028
RACE CARBURETORS	R4777-5	4150	650	37-485	37-933	6-504	122-67	122-73	N/A	N/A	125-65	0.028
RACE CARBURETORS	R4777-6	4150	650	37-485	37-933	6-504	122-67	122-73	N/A	N/A	125-65	0.028
RACE CARBURETORS	R4777-7	4150	650	37-485	37-933	6-504	122-67	122-73	N/A	N/A	125-65	0.028
THROTTLE BODIES	R4778	4150	700	37-485	37-933	6-504	122-66	122-71	N/S	N/S	125-65	0.025
THROTTLE BODIES	R4778-1	4150	700	37-485	37-933	6-504	122-66	122-76	N/S	N/S	125-65	0.028
THROTTLE BODIES	R4778-2	4150	700	37-485	37-933	6-504	122-66	122-76	N/S	N/S	125-65	0.028
THROTTLE BODIES	R4778-3	4150	700	37-485	37-933	6-504	122-69	122-78	N/S	N/S	125-65	0.028
THROTTLE BODIES	R4778-4	4150	700	37-485	37-933	6-504	122-69	122-78	N/S	N/S	125-65	0.028
THROTTLE BODIES	R4778-5	4150	700	37-485	37-933	6-504	122-69	122-78	N/A	N/A	125-65	0.028
THROTTLE BODIES	R4778-6	4150	700	37-485	37-933	6-504	122-69	122-78	N/A	N/A	125-65	0.028
THROTTLE BODIES	R4778-7	4150	700	37-485	37-933	6-504	122-69	122-78	N/A	N/A	125-65	0.028
THROTTLE BODIES	R4778-8	4150	700	37-485	37-933	6-504	122-69	122-78	N/A	N/A	125-65	0.028
FUEL PUMPS	R4779	4150	750	37-485	37-933	6-504	122-75	122-76	N/S	N/S	125-85	0.025
FUEL PUMPS	R4779-1	4150	750	37-485	37-933	6-504	122-70	122-80	N/S	N/S	125-85	0.028
FUEL PUMPS	R4779-2	4150	750	37-485	37-933	6-504	122-70	122-80	134-155	N/S	125-65	0.028
FUEL PUMPS	R4779-3	4150	750	37-485	37-933	6-504	122-70	122-73	N/A	N/S	125-65	0.028
FUEL PUMPS	R4779-4	4150	750	37-485	37-933	6-504	122-70	122-80	N/A	N/S	125-65	0.028
FUEL PUMPS	R4779-5	4150	750	37-485	37-933	6-504	122-70	122-80	N/A	N/S	125-65	0.028
FUEL PUMPS	R4779-6	4150	750	37-485	37-933	6-504	122-71	122-80	N/A	N/A	125-65	0.028
FUEL PUMPS	R4779-7	4150	750	37-485	37-933	6-504	122-71	122-80	N/A	N/A	125-65	0.028
FUEL PUMPS	R4779-8	4150	750	37-485	37-933	6-504	122-71	122-80	N/A	N/A	125-65	0.028
FUEL PUMPS	R4779-9	4150	750	37-485	37-933	6-504	122-71	122-80	134-61	134-62	125-65	0.028
INTAKE MANIFOLDS	R4780	4150	800	37-485	37-933	6-504	122-72	122-76	N/S	N/S	(12,21)	0.031
INTAKE MANIFOLDS	R4780-1	4150	800	37-485	37-933	6-504	122-70	122-76	N/S	N/S	(12,21)	0.031
INTAKE MANIFOLDS	R4780-2	4150	800	37-485	37-933	6-504	122-70	122-85	N/S	N/S	125-65	0.031
INTAKE MANIFOLDS	R4780-3	4150	800	37-485	37-933	6-504	122-71	122-85	N/A	N/S	125-65	0.031
INTAKE MANIFOLDS	R4780-4	4150	800	37-485	37-933	6-504	122-71	122-85	N/A	N/S	125-65	0.031
INTAKE MANIFOLDS	R4780-5	4150	800	37-485	37-933	6-504	122-71	122-85	N/A	N/A	125-65	0.031
INTAKE MANIFOLDS	R4780-6	4150	800	37-485	37-933	6-504	122-71	122-85	N/A	N/A	125-65	0.031
INTAKE MANIFOLDS	R4780-7	4150	800	37-485	37-933	6-504	122-71	122-85	N/A	N/A	125-65	0.031
INTAKE MANIFOLDS	R4781	4150	850	37-485	37-933	6-504	122-80	122-80	N/S	N/S	125-65 (15)	0.035
INTAKE MANIFOLDS	R4781-1	4150	850	37-485	37-933	6-504	122-80	122-80	N/S	N/S	125-65 (15)	0.031
INTAKE MANIFOLDS	R4781-2	4150	850	37-485	37-933	6-504	122-80	122-80	N/A	N/S	125-65 (15)	0.031
INTAKE MANIFOLDS	R4781-3	4150	850	37-485	37-933	6-504	122-80	122-78	N/S	N/S	125-65 (15)	0.031
INTAKE MANIFOLDS	R4781-4	4150	850	37-485	37-933	6-504	122-80	122-78	N/S	N/S	125-65 (15)	0.031

See pages 190 & 191 for numerical listing specific footnotes.

Secondary Nozzle Size or Spring Color	Primary Bowl Gasket ¹	Primary Metering Block Gasket	Secondary Bowl Gasket	Secondary Metering Block Gasket	Secondary Metering Plate Gasket	Primary Fuel Bowl	Secondary Fuel Bowl	Throttle Body & Shaft Assembly	Venturii Diameter Primary	Venturii Diameter Secondary	Throttle Bore Diameter Primary	Throttle Bore Diameter Secondary
Yellow	108-83-2	108-89-2	108-83-2	108-89-2	N/R	134-103	N/S	N/S	1-3/8	1-7/16	1-11/16	1-11/16
0.035	108-83-2	108-89-2	108-83-2	108-89-2	N/R	134-108	134-112	N/S	1-11/16	1-11/16	2	2
Yellow	108-83-2	108-89-2	108-83-2	108-89-2	N/R	N/S	N/S	N/S	1-3/8	1-7/16	1-11/16	1-11/16
Yellow	108-83-2	108-89-2	108-83-2	108-89-2	N/R	N/S	N/S	N/S	1-3/8	1-7/16	1-11/16	1-11/16
Purple	108-83-2	108-89-2	108-83-2	108-89-2	N/R	N/S	N/S	N/S	1-3/8	1-7/16	1-11/16	1-11/16
Purple	108-83-2	108-89-2	108-83-2	108-89-2	N/R	N/S	N/S	N/S	1-3/8	1-7/16	1-11/16	1-11/16
N/R	108-83-2	108-89-2	N/R	N/R	N/R	N/S	N/R	N/S	1-3/16	N/A	1-1/2	N/A
Yellow	N/R	N/R	108-90-2	108-90-2	108-13-2	N/R	N/S	N/S	1-9/16	N/A	1-3/4	N/A
N/R	N/R	N/R	N/R	N/R	N/R	N/R	N/R	N/R	1/5/32	N/R	1-7/16	N/R
Purple	108-83-2	108-89-2	108-83-2	108-89-2	N/R	N/S	N/S	N/S	1-1/4	1-5/16	1-9/16	1-9/16
0.032	108-83-2	108-89-2	108-83-2	108-89-2	N/R	134-103	134-104	N/S	1-1/4	1-5/16	1-9/16	1-9/16
0.032	108-83-2	108-89-2	108-83-2	108-89-2	N/R	134-103	134-104	N/S	1-1/4	1-5/16	1-9/16	1-9/16
0.032	108-83-2	108-89-2	108-83-2	108-89-2	N/R	134-103	134-104	N/A	1-1/4	1-5/16	1-9/16	1-9/16
0.032	108-83-2	108-89-2	108-83-2	108-89-2	N/R	134-103	134-104	N/A	1-1/4	1-5/16	1-9/16	1-9/16
0.032	108-83-2	108-89-2	108-83-2	108-89-2	N/R	134-103S	134-104S	N/A	1-1/4	1-5/16	1-9/16	1-9/16
0.032	108-83-2	108-89-2	108-83-2	108-89-2	N/R	134-103	134-104	N/A	1-1/4	1-5/16	1-9/16	1-9/16
0.032	108-83-2	108-89-2	108-83-2	108-89-2	N/R	134-103	134-104	112-118	1-1/4	1-5/16	1-9/16	1-9/16
0.025	108-83-2	108-89-2	108-83-2	108-89-2	N/R	134-103	134-104	N/S	1-1/4	1-5/16	1-11/16	1-11/16
0.028	108-83-2	108-89-2	108-83-2	108-89-2	N/R	134-103	134-104	N/S	1-1/4	1-5/16	1-11/16	1-11/16
0.028	108-83-2	108-89-2	108-83-2	108-89-2	N/R	134-103	134-104	112-17	1-1/4	1-5/16	1-11/16	1-11/16
0.028	108-83-2	108-89-2	108-83-2	108-89-2	N/R	134-103	134-104	112-17	1-1/4	1-5/16	1-11/16	1-11/16
0.028	108-83-2	108-89-2	108-83-2	108-89-2	N/R	134-103S	134-104S	N/A	1-1/4	1-5/16	1-11/16	1-11/16
0.028	108-83-2	108-89-2	108-83-2	108-89-2	N/R	134-103S	134-104S	N/A	1-1/4	1-5/16	1-11/16	1-11/16
0.028	108-83-2	108-89-2	108-83-2	108-89-2	N/R	134-103	134-104	N/A	1-1/4	1-5/16	1-11/16	1-11/16
0.032	108-83-2	108-89-2	108-83-2	108-89-2	N/R	134-103	134-104	N/S	1-5/16	1-3/8	1-11/16	1-11/16
0.031	108-83-2	108-89-2	108-83-2	108-89-2	N/R	134-103	134-104	N/S	1-5/16	1-3/8	1-11/16	1-11/16
0.031	108-83-2	108-89-2	108-83-2	108-89-2	N/R	134-103	134-104	N/A	1-5/16	1-3/8	1-11/16	1-11/16
0.031	108-83-2	108-89-2	108-83-2	108-89-2	N/R	134-103	134-104	N/A	1-5/16	1-3/8	1-11/16	1-11/16
0.031	108-83-2	108-89-2	108-83-2	108-89-2	N/R	134-103	134-104	N/A	1-5/16	1-3/8	1-11/16	1-11/16
0.031	108-83-2	108-89-2	108-83-2	108-89-2	N/R	134-103S	134-104S	N/A	1-5/16	1-3/8	1-11/16	1-11/16
0.031	108-83-2	108-89-2	108-83-2	108-89-2	N/R	134-103	134-104	N/A	1-5/16	1-3/8	1-11/16	1-11/16
0.031	108-83-2	108-89-2	108-83-2	108-89-2	N/R	134-103	134-104	N/A	1-5/16	1-3/8	1-11/16	1-11/16
0.031	108-83-2	108-89-2	108-83-2	108-89-2	N/R	134-103	134-104	N/S	1-3/8	1-3/8	1-11/16	1-11/16
0.031	108-83-2	108-89-2	108-83-2	108-89-2	N/R	134-103	134-104	N/S	1-3/8	1-3/8	1-11/16	1-11/16
0.031	108-83-2	108-89-2	108-83-2	108-89-2	N/R	134-103	134-104	N/S	1-3/8	1-3/8	1-11/16	1-11/16
0.031	108-83-2	108-89-2	108-83-2	108-89-2	N/R	134-103	134-104	N/A	1-3/8	1-3/8	1-11/16	1-11/16
0.031	108-83-2	108-89-2	108-83-2	108-89-2	N/R	134-103S	134-104S	N/A	1-3/8	1-3/8	1-11/16	1-11/16
0.031	108-83-2	108-89-2	108-83-2	108-89-2	N/R	134-103S	134-104S	N/A	1-3/8	1-3/8	1-11/16	1-11/16
0.031	108-83-2	108-89-2	108-83-2	108-89-2	N/R	134-103	134-104	112-116	1-3/8	1-3/8	1-11/16	1-11/16
0.031	108-83-2	108-89-2	108-83-2	108-89-2	N/R	134-103	134-104	N/S	1-3/8	1-7/16	1-11/16	1-11/16
0.031	108-83-2	108-89-2	108-83-2	108-89-2	N/R	134-103	134-104	N/S	1-3/8	1-7/16	1-11/16	1-11/16
0.031	108-83-2	108-89-2	108-83-2	108-89-2	N/R	134-103	134-104	N/A	1-3/8	1-7/16	1-11/16	1-11/16
0.031	108-83-2	108-89-2	108-83-2	108-89-2	N/R	134-103	134-104	N/A	1-3/8	1-7/16	1-11/16	1-11/16
0.031	108-83-2	108-89-2	108-83-2	108-89-2	N/R	134-103	134-104	N/A	1-3/8	1-7/16	1-11/16	1-11/16
0.031	108-83-2	108-89-2	108-83-2	108-89-2	N/R	134-103S	134-104S	N/A	1-3/8	1-7/16	1-11/16	1-11/16
0.031	108-83-2	108-89-2	108-83-2	108-89-2	N/R	134-103	134-104	N/A	1-3/8	1-7/16	1-11/16	1-11/16
0.031	108-83-2	108-89-2	108-83-2	108-89-2	N/R	134-103	134-104	N/A	1-3/8	1-7/16	1-11/16	1-11/16
0.031	108-83-2	108-89-2	108-83-2	108-89-2	N/R	134-103	134-104	N/S	1-9/16	1-9/16	1-3/4	1-3/4
0.031	108-83-2	108-89-2	108-83-2	108-89-2	N/R	134-103	134-104	N/S	1-9/16	1-9/16	1-3/4	1-3/4
0.031	108-83-2	108-89-2	108-83-2	108-89-2	N/R	134-103	134-104	N/S	1-9/16	1-9/16	1-3/4	1-3/4

See pages 190 & 191 for numerical listing specific footnotes.

HOW TO CHOOSE A CARB
STREET CARBURETORS
SUPERCHARGER CARBURETORS
RACE CARBURETORS
MARINE CARBURETORS
CARB SERVICE PARTS & ACCESSORIES
FUEL INJECTION
THROTTLE BODIES
FUEL PUMPS
INTAKE MANIFOLDS
CYLINDER HEADS
SYSTEMAX
ENGINE DRESS-UP
MERCHANDISING
TECHNICAL INFORMATION
INDEX

HOW TO CHOOSE A CARB	Carburetor Part No.	Carb. Model No.	CFM	Renew Kit	Trick Kit	Needle & Seal	Primary Main Jet	Secondary Main Jet or Plate	Primary Metering Block	Secondary Metering Block	Power Valve	Pump Nozzle Size, Primary
STREET CARBURETORS	R4781-5	4150	850	37-485	37-933	6-504	122-80	122-78	N/A	N/S	125-65 (15)	0.031
STREET CARBURETORS	R4781-6	4150	850	37-485	37-933	6-504	122-80	122-78	N/A	N/A	125-65 (15)	0.031
STREET CARBURETORS	R4781-7	4150	850	37-485	37-933	6-504	122-80	122-78	N/A	N/A	125-65 (15)	0.031
STREET CARBURETORS	R4781-8	4150	850	37-485	37-933	6-504	122-80	122-78	134-65	134-66	125-65 (15)	0.031
SUPERCHARGER CARBURETORS	R4782	2300	355	37-1537	37-933	6-504	122-64	N/R	N/S	N/R	125-65	0.031
SUPERCHARGER CARBURETORS	R4783	2300	500	37-1537	37-933	6-504	122-82	N/R	N/R	N/S	N/R	0.028
SUPERCHARGER CARBURETORS	R4788	4150	830	37-485	37-933	6-504	122-80	122-80	N/S	N/S	125-65 (B)	0.031
SUPERCHARGER CARBURETORS	R4788-1	4150	830	37-485	37-933	6-504	122-80	122-80	N/S	N/S	125-65 (B)	0.031
SUPERCHARGER CARBURETORS	R4790	2300	500	37-1537	37-933	6-504	N/R	N/S	N/R	N/R	N/R	N/R
SUPERCHARGER CARBURETORS	R4791	2300	350	37-1537	37-933	6-504	122-62	N/R	N/S	N/R	125-65	0.031
RACE CARBURETORS	R4792	2300	350	37-1537	37-933	6-504	122-61	N/R	N/S	N/R	125-65	0.031
RACE CARBURETORS	R4800-1	4150	780	37-1539	37-933	6-504	122-70	122-76	N/S	N/S	125-85 (12)	0.025
RACE CARBURETORS	R4801-1	4150	780	37-1539	37-933	6-504	122-70	122-76	N/S	N/S	128-85 (12)	0.025
RACE CARBURETORS	R4802-1	4150	780	37-1539	37-933	6-504	122-70	122-76	N/S	N/S	125-85 (12)	0.025
RACE CARBURETORS	R4803-1	4150	780	37-1539	37-933	6-504	122-70	122-76	N/S	N/S	125-85 (12)	0.025
MARINE CARBURETORS	R6109	4150	750	37-485	37-933	6-504	122-75	122-76	N/S	N/S	125-85	0.025
MARINE CARBURETORS	R6129	4150	780	37-1537	37-933	6-504	122-70	122-82	N/S	N/S	125-65	0.026
CARB SERVICE PARTS & ACCESSORIES	R6210-1	4165	650	37-605	37-933	(16,17)	122-602	122-632	N/S	N/S	(14,15)	0.025
CARB SERVICE PARTS & ACCESSORIES	R6210-2	4165	650	37-605	37-933	(16,17)	122-602	122-83	N/S	N/S	125-85	0.025
CARB SERVICE PARTS & ACCESSORIES	R6210-3	4165	650	37-605	37-933	(16,17)	122-602	122-83	N/S	N/S	125-85	0.025
FUEL INJECTION	R6211	4165	800	37-605	37-933	16,17	122-62	122-85	N/S	N/S	(14,15)	0.025
FUEL INJECTION	R6211-1	4165	800	37-605	37-933	(16,17)	122-602	122-85	N/S	N/S	(14,15)	0.025
FUEL INJECTION	R6212	4165	800	37-1537	37-933	6-504	122-63	122-86	N/S	N/S	(14,15)	0.025
FUEL INJECTION	R6213	4165	800	37-1537	37-933	6-504	122-62	122-85	N/S	N/S	(14,15)	0.025
FUEL INJECTION	R6214	4500	1150	N/A	N/A	6-504	122-95	122-95	N/S	N/S	N/R	0.026
THROTTLE BODIES	R6238-1	4150	780	37-1539	37-933	6-504	122-68	122-73	N/S	N/S	125-65 (12)	0.025
THROTTLE BODIES	R6239-1	4150	780	37-1539	37-933	6-504	122-68	122-73	N/S	N/S	125-65 (12)	0.025
THROTTLE BODIES	R6244-1	2110	200	N/A	N/A	6-509	122-47	N/R	N/R	N/R	N/R	0.021
THROTTLE BODIES	R6262	4165	800	37-605	37-933	(16,17)	122-62	122-85	N/S	N/S	(14,15)	0.025
THROTTLE BODIES	R6270-1	4160	600	37-1536	37-933	N/S	122-64	N/S	N/S	N/S	125-85	0.032
FUEL PUMPS	R6291	4160	600	37-119	37-933	6-506	122-62	134-39	N/S	N/S	125-85	0.031
FUEL PUMPS	R6299-1	4160	390	37-1539	37-933	6-506	122-50	34R9716-34	N/S	N/S	N/A	0.025
FUEL PUMPS	R6425	2300	650	N/A	N/A	6-504	122-82	N/R	N/S	N/S	125-65	0.031
FUEL PUMPS	R6464	4500	1050	37-1539	37-933	6-504	122-88	122-88	N/S	N/R	N/R	0.035
FUEL PUMPS	R6468-1	4165	650	37-605	37-933	(16,17)	122-60	122-83	N/S	N/S	125-85	0.025
FUEL PUMPS	R6468-2	4165	650	37-605	37-933	(16,17)	122-602	122-83	N/S	N/A	125-85	0.025
FUEL PUMPS	R6497	4165	650	37-605	37-933	(16,17)	122-582	122-602	N/S	N/S	(14,15)	0.025
FUEL PUMPS	R6498	4165	650	37-605	37-933	(16,17)	122-592	122-602	N/S	N/S	(14,15)	0.025
FUEL PUMPS	R6499	4165	650	37-1537	N/A	6-504	122-60	122-63	N/S	N/S	(14,15)	0.025
FUEL PUMPS	R6512	4165	650	37-605	37-933	(16,17)	122-60	122-60	N/S	N/S	(14,15)	0.025
CYLINDER HEADS	R6520	4160	600	37-119	37-933	6-506	122-62	134-39	N/S	N/S	125-85	0.031
CYLINDER HEADS	R6528	4165	650	37-605	37-933	(16,17)	122-61	122-60	N/S	N/S	(14,15)	0.025
CYLINDER HEADS	R6619-1	4160	600	37-720	37-933	6-506	122-642	134-39	N/S	134-39	125-65	0.031
CYLINDER HEADS	R6647	4150	600	3-655	N/A	6-504	122-68	122-70	N/S	N/S	125-85 (12)	0.025
CYLINDER HEADS	R6708	4150	650	37-1539	37-933	6-504	122-552	122-752	N/S	134-39	(21,22)	0.025
ENGINE DRESS-UP	R6708-1	4150	650	37-1539	37-933	6-504	122-542	122-85	N/S	N/S	125-65	0.025
ENGINE DRESS-UP	R6709	4150	750	37-1539	37-933	6-504	122-652	122-76	N/S	N/S	(21,22)	0.025
ENGINE DRESS-UP	R6710	4165	800	37-1537	37-933	6-504	122-63	122-86	N/S	N/S	(21,22)	0.025
ENGINE DRESS-UP	R6711	4165	650	37-605	37-933	(16,17)	122-602	122-632	N/S	N/S	(21,22)	0.025
ENGINE DRESS-UP	R6772	4165	650	37-605	37-933	(16,17)	122-592	122-602	N/S	N/S	(14,15)	0.025
ENGINE DRESS-UP	R6773	4165	650	37-605	37-933	(16,17)	122-592	122-602	N/S	N/S	(14,15)	0.025
ENGINE DRESS-UP	R6774	4165	650	37-605	37-933	(16,17)	122-572	122-602	N/S	N/S	(14,15)	0.025
ENGINE DRESS-UP	R6853	4165	650	37-605	37-933	(16,17)	122-60	122-62	N/S	N/S	(14,15)	0.025
ENGINE DRESS-UP	R6895	4150	390	37-1536	37-933	6-504	122-50	122-62	N/S	N/S	125-85	0.025
ENGINE DRESS-UP	R6909	4160	600	37-119	37-933	6-506	122-622	134-39	N/S	134-39	125-65	0.031
ENGINE DRESS-UP	R6910	4165	800	37-1537	37-933	6-504	122-612	122-86	N/S	N/S	(14,15)	0.025
ENGINE DRESS-UP	R6919	4160	600	37-1536	37-933	6-506	122-622	134-39	N/S	134-39	125-206	0.031

See pages 190 & 191 for numerical listing specific footnotes.

Secondary Nozzle Size or Spring Color	Primary Bowl Gasket*	Primary Metering Block Gasket	Secondary Bowl Gasket	Secondary Metering Block Gasket	Secondary Metering Plate Gasket	Primary Fuel Bowl	Secondary Fuel Bowl	Throttle Body & Shaft Assembly	Venturii Diameter Primary	Venturii Diameter Secondary	Throttle Bore Diameter Primary	Throttle Bore Diameter Secondary
0.031	108-83-2	108-89-2	108-83-2	108-89-2	N/R	134-103	134-104	N/A	1-9/16	1-9/16	1-3/4	1-3/4
0.031	108-83-2	108-89-2	108-83-2	108-89-2	N/R	134-103S	134-104S	N/A	1-9/16	1-9/16	1-3/4	1-3/4
0.031	108-83-2	108-89-2	108-83-2	108-89-2	N/R	134-103	134-104	N/A	1-9/16	1-9/16	1-3/4	1-3/4
0.031	108-83-2	108-89-2	108-83-2	108-89-2	N/R	134-103	134-104	112-119	1-9/16	1-9/16	1-3/4	1-3/4
N/R	108-83-2	108-89-2	N/R	N/R	N/R	N/S	N/R	N/S	1-3/16	N/R	1-1/2	N/R
N/R	108-83-2	108-89-2	N/R	N/R	N/R	N/S	N/R	N/S	1-9/16	N/R	1-3/4	N/R
0.031	108-83-2	108-89-2	108-83-2	108-89-2	N/R	134-103	134-104	N/S	1-9/16	1-9/16	1-11/16	1-11/16
0.031	108-83-2	108-89-2	108-83-2	108-89-2	N/R	134-103	134-104	N/S	1-9/16	1-9/16	1-11/16	1-11/16
Yellow	N/R	N/R	108-90-2	108-90-2	108-13-2	N/R	N/S	N/S	1-9/16	N/R	1-3/4	N/R
N/R	108-83-2	108-89-2	N/R	N/R	N/R	N/S	N/R	N/S	1-3/16	N/R	1-1/2	N/R
N/R	108-83-2	108-89-2	N/R	N/R	N/R	N/S	N/R	N/S	1-3/16	N/R	1-1/2	N/R
Yellow	108-83-2	108-89-2	108-83-2	108-89-2	N/R	134-103	N/S	N/S	1-3/8	1-7/16	1-11/16	1-11/16
Yellow	108-83-2	108-89-2	108-83-2	108-89-2	N/R	134-103	N/S	N/S	1-3/8	1-7/16	1-11/16	1-11/16
Yellow	108-83-2	108-89-2	108-83-2	108-89-2	N/R	134-103	N/S	N/S	1-3/8	1-7/16	1-11/16	1-11/16
Yellow	108-83-2	108-89-2	108-83-2	108-89-2	N/R	134-103	N/S	N/S	1-3/8	1-7/16	1-11/16	1-11/16
0.032	108-83-2	108-89-2	108-83-2	108-89-2	N/R	N/S	N/S	N/S	1-3/8	1-3/8	1-11/16	1-11/16
Purple	108-83-2	108-89-2	108-83-2	108-89-2	N/R	N/S	N/S	N/S	1-3/8	1-7/16	1-11/16	1-11/16
0.037	108-92-2	108-91-2	108-92-2	108-91-2	N/R	134-110	N/A	N/S	1-5/32	1-3/8	1-3/8	2
0.037	108-92-2	108-91-2	108-92-2	108-91-2	N/R	134-110	N/A	N/S	1-5/32	1-3/8	1-3/8	2
0.037	108-92-2	108-91-2	108-92-2	108-91-2	N/R	134-110	N/A	N/A	1-5/32	1-3/8	1-3/8	2
0.037	108-92-2	108-91-2	108-92-2	108-91-2	N/R	134-110	N/A	N/S	1-5/32	1-23/32	1-3/8	2
0.037	108-92-2	108-91-2	108-92-2	108-91-2	N/R	134-110	N/A	N/S	1-5/32	1-23/32	1-3/8	2
0.037	108-92-2	108-91-2	108-92-2	108-91-2	N/R	134-110	N/A	N/S	1-5/32	1-23/32	1-3/8	2
0.037	108-92-2	108-91-2	108-92-2	108-91-2	N/R	134-110	N/A	N/S	1-5/32	1-23/32	1-3/8	2
0.026	108-83-2	108-36-2	108-83-2	108-36-2	N/R	134-108	134-112	N/S	1-13/16	1-13/16	2	2
Yellow	108-83-2	108-89-2	108-83-2	108-89-2	N/R	N/S	N/S	N/S	1-3/8	1-7/16	1-11/16	1-11/16
Yellow	108-83-2	108-89-2	108-83-2	108-89-2	N/R	N/S	N/S	N/S	1-3/8	1-7/16	1-11/16	1-11/16
N/R	N/R	N/R	N/R	N/R	N/R	N/R	N/R	N/R	1-5/16	N/R	1-7/16	N/R
0.037	108-92-2	108-91-2	108-92-2	108-91-2	N/R	134-110	N/A	N/S	1-13/16	1-23/32	1-3/8	2
Orange	108-83-2	108-34-2	108-90-2	108-90-2	108-27-2	N/S	N/S	N/S	1-1/4	1-5/16	1-9/16	1-9/16
Purple	108-83-2	108-91-2	108-90-2	108-90-2	108-27-2	N/S	N/S	N/S	1-1/4	1-5/16	1-5/16	1-9/16
Plain	108-83-2	108-89-2	108-90-2	108-90-2	108-28-2	N/S	N/S	N/S	1-1/16	1-1/16	1-7/16	1-7/16
N/R	108-92-2	108-35-2	N/R	N/R	N/R	N/S	N/S	N/S	1-7/16	N/R	1-3/4	N/R
0.035	108-83-2	108-36-2	108-83-2	108-36-2	N/R	134-108	134-112	N/S	1-11/16	1-11/16	2	2
0.037	108-92-2	108-91-2	108-92-2	108-91-2	N/R	134-110	N/A	N/S	1-5/32	1-3/8	1-3/8	2
0.037	108-92-2	108-91-2	108-92-2	108-91-2	N/R	134-110	N/A	N/S	1-5/32	1-3/8	1-3/8	2
0.037	108-92-2	108-91-2	108-92-2	108-91-2	N/R	134-110	N/A	N/S	1-5/32	1-3/8	1-3/8	2
0.037	108-92-2	108-91-2	108-92-2	108-91-2	N/R	134-110	N/A	N/S	1-5/32	1-3/8	1-3/8	2
0.037	108-92-2	108-91-2	108-92-2	108-91-2	N/R	134-110	N/A	N/S	1-5/32	1-3/8	1-3/8	2
Purple	108-83-2	108-91-2	108-90-2	108-90-2	108-27-2	N/S	N/S	N/S	1-1/4	1-5/16	1-9/16	1-9/16
0.037	108-92-2	108-91-2	108-92-2	108-91-2	N/R	134-110	N/A	N/S	1-5/32	1-3/8	1-3/8	2
Black	108-83-2	108-91-2	108-90-2	108-90-2	108-27-2	N/A	134-105	N/S	1-1/4	1-5/16	1-9/16	1-9/16
Yellow	108-83-2	108-89-2	108-83-2	108-89-2	N/R	N/S	N/S	N/S	1-1/4	1-5/16	1-9/16	1-9/16
0.037	108-92-2	108-91-2	108-92-2	108-91-2	N/R	N/S	N/S	N/S	1-3/32	1-9/16	1-1/2	1-3/4
0.037	108-92-2	108-91-2	108-92-2	108-91-2	N/R	N/S	N/S	N/S	1-1/4	1-9/16	1-1/2	1-3/4
0.037	108-92-2	108-91-2	108-92-2	108-91-2	N/R	N/S	N/S	N/S	1-5/32	1-23/32	1-3/8	2
0.028	108-92-2	108-91-2	108-92-2	108-91-2	N/R	N/S	N/A	N/S	1-5/32	1-3/8	1-3/8	2
0.04	108-92-2	108-91-2	108-92-2	108-91-2	N/R	134-110	N/A	N/S	1-5/32	1-3/8	1-3/8	2
0.04	108-92-2	108-91-2	108-92-2	108-91-2	N/R	134-110	N/A	N/S	1-5/32	1-3/8	1-3/8	2
0.037	108-92-2	108-91-2	108-92-2	108-91-2	N/R	134-110	N/A	N/S	1-5/32	1-3/8	1-3/8	2
0.037	108-92-2	108-91-2	108-92-2	108-91-2	N/R	134-110	N/A	N/S	1-5/32	1-3/8	1-3/8	2
0.025	108-83-2	108-89-2	108-83-2	108-89-2	N/R	134-103	134-104	N/S	1-1/16	1-1/16	1-7/16	1-7/16
Black	108-83-2	108-91-2	108-90-2	108-90-2	108-27-2	N/S	134-105	N/S	1-1/4	1-5/16	1-9/16	1-9/16
0.037	108-92-2	108-91-2	108-92-2	108-91-2	N/R	N/S	N/S	N/S	1-5/32	1-23/32	1-3/8	2
Black	108-83-2	108-91-2	108-90-2	108-90-2	108-27-2	N/A	134-105	N/S	1-1/4	1-5/16	1-9/16	1-9/16

See pages 190 & 191 for numerical listing specific footnotes.

HOW TO CHOOSE A CARB
STREET CARBURETORS
SUPERCHARGER CARBURETORS
RACE CARBURETORS
MARINE CARBURETORS
CARB SERVICE PARTS & ACCESSORIES
FUEL INJECTION
THROTTLE BODIES
FUEL PUMPS
INTAKE MANIFOLDS
CYLINDER HEADS
SYSTEMAX
ENGINE DRESS-UP
MERCHANDISING
TECHNICAL INFORMATION
INDEX

HOW TO CHOOSE A CARB	Carburetor Part No.	Carb. Model No.	CFM	Renew Kit	Trick Kit	Needle & Seal	Primary Main Jet	Secondary Main Jet or Plate	Primary Metering Block	Secondary Metering Block	Power Valve	Pump Nozzle Size, Primary
STREET CARBURETORS	R6946-1	4160	600	3-1012	N/A	6-504	122-612	N/S	N/S	N/S	125-211	0.025
STREET CARBURETORS	R6947	4160	600	3-1012	N/A	6-504	122-612	N/S	N/S	N/S	125-206	0.025
STREET CARBURETORS	R6979	4160	600	N/A	37-933	6-506	122-642	134-39	N/S	134-39	125-85	0.031
STREET CARBURETORS	R6979-1	4160	600	N/A	37-933	6-506	122-642	134-39	N/S	134-39	125-208	0.031
STREET CARBURETORS	R6989	4160	600	37-1536	37-933	6-506	122-622	134-39	N/S	134-39	125-206	0.031
SUPERCARGER CARBURETORS	R7001	4165	650	N/A	37-933	(16,17)	122-582	122-602	N/S	N/S	(15,24)	0.025
SUPERCARGER CARBURETORS	R7002-1	4175	650	37-1537	37-933	(16,17)	122-582	134-21	N/S	134-21	125-85	0.025
SUPERCARGER CARBURETORS	R7004-1	4175	650	37-1537	37-933	(16,17)	122-562	N/A	N/S	N/A	125-212	0.025
SUPERCARGER CARBURETORS	R7004-2	4175	650	37-1537	37-933	(16,17)	122-542	N/S	N/S	N/S	125-211	0.025
SUPERCARGER CARBURETORS	R7005-1	4175	650	37-1537	37-933	(16,17)	122-562	N/A	N/S	N/A	125-212	0.025
RACE CARBURETORS	R7005-2	4175	650	37-1537	37-933	(16,17)	122-542	N/S	N/S	N/S	125-212	0.025
RACE CARBURETORS	R7006-1	4175	650	37-1537	37-933	(16,17)	122-562	N/A	N/S	N/A	125-212	0.025
RACE CARBURETORS	R7006-2	4175	650	37-1537	37-933	(16,17)	122-542	N/S	N/S	N/S	125-211	0.025
MARINE CARBURETORS	R7009-1	4160	600	37-1536	37-933	6-506	122-622	134-39	N/S	134-39	125-206	0.031
MARINE CARBURETORS	R7010	4160	780	37-1537	37-933	6-506	122-662	N/S	N/S	N/S	125-65	0.025
CARB SERVICE PARTS & ACCESSORIES	R7053-1	4160	600	37-119	37-933	6-506	122-632	134-39	N/S	N/S	125-85	0.031
CARB SERVICE PARTS & ACCESSORIES	R7054	4165	650	37-605	37-933	(16,17)	122-592	122-602	N/S	N/S	(14,15)	0.025
CARB SERVICE PARTS & ACCESSORIES	R7154	4160	600	37-119	37-933	6-506	122-62	N/S	N/S	N/S	125-85	0.031
CARB SERVICE PARTS & ACCESSORIES	R7320	4500	1150	37-1539	37-933	6-504	122-95	122-95	N/S	N/S	N/A	0.031
CARB SERVICE PARTS & ACCESSORIES	R7320-1	4500	1150	37-1539	37-933	6-518-2	122-95	122-95	N/S	N/S	N/R	0.031
CARB SERVICE PARTS & ACCESSORIES	R7320-2	4500	1150	37-1539	37-933	6-518-2	122-95	122-95	N/S	N/S	N/R	0.031
FUEL INJECTION	R7343	5200	230	N/A	N/A	N/S	N/S	N/S	N/S	N/S	N/S	0.02
FUEL INJECTION	R7344	5210	255	N/A	N/A	N/S	N/S	N/S	N/S	N/S	N/S	0.021
FUEL INJECTION	R7351	4175	650	37-1537	37-933	(16,17)	122-592	N/S	N/S	134-21	125-206	0.037
FUEL INJECTION	R7397	4175	650	37-1537	37-933	(16,17)	122-582	134-21	N/S	134-21	125-206	0.037
THROTTLE BODIES	R7410	4150	340	37-1536	37-933	6-504	122-50	122-62	N/S	N/S	125-85	0.025
THROTTLE BODIES	R7411	4150	370	37-1536	37-933	6-504	122-50	122-62	N/S	N/S	125-85	0.025
THROTTLE BODIES	R7413	4160	600	37-119	37-933	6-506	122-632	134-39	N/S	N/S	125-85	0.031
THROTTLE BODIES	R7448	2300	350	37-1536	37-933	6-504	122-61	N/A	134-203	N/R	125-85	0.031
THROTTLE BODIES	R7448-1	2300	350	37-1536	37-933	6-504	122-61	N/A	134-203	N/R	125-85	0.031
FUEL PUMPS	R7454	4360	450	37-1540	N/A	N/S	124-215	124-550	N/R	N/R	N/S	0.028
FUEL PUMPS	R7455	4360	450	37-1540	N/A	N/S	124-215	124-537	N/R	N/R	N/S	0.028
FUEL PUMPS	R7456	4360	450	37-1540	N/A	N/S	124-215	124-550	N/R	N/R	N/S	0.028
FUEL PUMPS	R7555	4360	450	37-1540	N/A	N/S	124-215	124-550	N/R	N/R	N/S	0.028
FUEL PUMPS	R7556	4360	450	37-1540	N/A	N/S	124-215	124-550	N/R	N/R	N/S	0.028
INTAKE MANIFOLDS	R7850	4160	600	N/A	N/A	6-506	122-622	134-39	N/S	N/S	125-85	0.031
INTAKE MANIFOLDS	R7855	4175	650	37-1537	37-933	(16,17)	122-562	N/A	N/S	N/A	125-212	0.028
INTAKE MANIFOLDS	R7955	4360	450	37-1540	N/A	N/S	124-219	124-550	N/R	N/R	N/S	0.028
INTAKE MANIFOLDS	R7956	4360	450	37-1540	N/A	N/S	124-239	124-550	N/R	N/R	N/S	0.028
INTAKE MANIFOLDS	R7957	4360	450	37-1540	N/A	N/S	124-219	124-550	N/R	N/R	N/S	0.028
CYLINDER HEADS	R7958	4360	450	37-1540	N/A	N/S	124-219	124-550	N/R	N/R	N/S	0.028
CYLINDER HEADS	R7985	4160	600	37-1536	37-933	6-506	122-632	134-39	N/S	134-39	125-208	0.031
CYLINDER HEADS	R7986	4160	600	37-1536	37-933	6-506	125-652	134-39	N/S	134-39	125-208	0.031
CYLINDER HEADS	R7987	4160	600	37-1536	37-933	6-506	122-612	134-39	N/S	134-39	125-208	0.031
SYSTEMAX	R8001	4360	450	37-1540	N/A	N/S	124-215	124-550	N/R	N/R	N/S	0.028
SYSTEMAX	R8002	4360	450	37-1540	N/A	N/S	124-215	124-550	N/R	N/R	N/S	0.028
SYSTEMAX	R8003	4360	450	37-1540	N/A	N/S	124-235	124-550	N/R	N/R	N/S	0.028
SYSTEMAX	R8004	4160	600	37-1536	37-933	6-506	122-632	134-39	N/S	134-39	125-208	0.031
SYSTEMAX	R8005	4160	600	37-1536	37-933	6-506	122-622	134-39	N/S	134-39	125-208	0.031
SYSTEMAX	R8006	4160	600	37-1536	37-933	6-506	122-622	134-39	N/S	134-39	125-208	0.031
ENGINE DRESS-UP	R8007	4160	390	37-720	37-933	6-506	122-51	N/A	N/A	N/A	125-65	0.025
ENGINE DRESS-UP	R8059	4175	650	37-1537	37-933	(16,17)	122-582	134-21	N/S	134-21	125-206	0.037
ENGINE DRESS-UP	R8059-1	4175	650	37-1537	37-933	(16,17)	122-582	N/S	N/S	N/S	125-211	0.025
ENGINE DRESS-UP	R8060	4175	650	37-1537	37-933	(16,17)	122-582	134-21	N/S	134-21	125-206	0.037
ENGINE DRESS-UP	R8060-1	4175	650	37-1537	37-933	(16,17)	122-582	N/S	N/S	N/S	N/S	0.025
MERCHANDISING	R8082	4500	1050	37-1539	37-933	6-504	122-84	122-84	N/S	N/S	125-65	0.035
MERCHANDISING	R8082-1	4500	1050	37-1539	37-933	6-504	122-88	122-88	N/S	N/S	125-65 (15)	0.035

See pages 190 & 191 for numerical listing specific footnotes.

Secondary Nozzle Size or Spring Color	Primary Bowl Gasket ¹	Primary Metering Block Gasket	Secondary Bowl Gasket	Secondary Metering Block Gasket	Secondary Metering Plate Gasket	Primary Fuel Bowl	Secondary Fuel Bowl	Throttle Body & Shaft Assembly	Venturii Diameter Primary	Venturii Diameter Secondary	Throttle Bore Diameter Primary	Throttle Bore Diameter Secondary
Plain	108-83-2	108-91-2	108-90-2	108-90-2	108-27-2	N/S	N/S	N/S	1-3/16	1-1/4	1-1/2	1-1/2
Plain	108-83-2	108-91-2	108-90-2	108-90-2	108-27-2	N/S	N/S	N/S	1-3/16	1-1/4	1-1/2	1-1/2
Black	108-83-2	108-91-2	108-90-2	108-90-2	108-27-2	134-101	134-105	N/S	1-1/4	1-5/16	1-9/16	1-9/16
Black	108-83-2	108-91-2	108-90-2	108-90-2	108-27-2	134-101	134-105	N/S	1-1/4	1-5/16	1-9/16	1-9/16
Black	108-83-2	108-91-2	108-90-2	108-90-2	108-27-2	N/A	134-105	N/S	1-1/4	1-5/16	1-9/16	1-9/16
0.037	108-92-2	108-91-2	108-92-2	108-91-2	N/R	134-110	N/A	N/S	1-5/32	1-3/8	1-3/8	2
Black	108-92-2	108-91-2	108-90-2	108-90-2	108-27-2	134-110	N/A	N/S	1-5/32	1-3/8	1-3/8	2
Plain	108-92-2	108-91-2	108-90-2	108-90-2	108-27-2	N/S	N/A	N/S	1-5/32	1-3/8	1-3/8	2
Plain	108-92-2	108-91-2	108-90-2	108-90-2	108-27-2	N/S	N/A	N/S	1-5/32	1-3/8	1-3/8	2
Plain	108-92-2	108-91-2	108-90-2	108-90-2	108-27-2	N/S	N/A	N/S	1-5/32	1-3/8	1-3/8	2
Plain	108-92-2	108-91-2	108-90-2	108-90-2	108-27-2	N/S	N/A	N/S	1-5/32	1-3/8	1-3/8	2
Plain	108-92-2	108-91-2	108-90-2	108-90-2	108-27-2	N/S	N/A	N/S	1-5/32	1-3/8	1-3/8	2
Black	108-83-2	108-91-2	108-90-2	108-90-2	108-27-2	N/S	134-105	N/S	1-1/4	1-5/16	1-9/16	1-9/16
Black	108-92-2	108-91-2	108-90-2	108-90-2	108-27-2	N/S	134-102	N/S	1-1/4	1-9/16	1-1/2	1-3/4
Purple	108-83-2	108-91-2	108-90-2	108-90-2	108-27-2	N/S	N/S	N/S	1-1/4	1-5/16	1-9/16	1-9/16
0.037	108-92-2	108-91-2	108-83-2	108-91-2	N/R	134-110	N/A	N/S	1-5/32	1-3/8	1-3/8	2
Purple	108-83-2	108-91-2	108-90-2	108-90-2	108-27-2	N/S	N/S	N/S	1-1/4	1-5/16	1-9/16	1-9/16
0.035	108-105	108-106	108-105	108-106	N/R	134-108	134-112	N/S	1-13/16	1-13/16	2	2
0.035	108-105	108-106	108-105	108-106	N/R	134-108	134-112	N/S	1-13/16	1-13/16	2	2
0.035	108-105	108-106	108-105	108-106	N/R	134-108	134-112	N/S	1-13/16	1-13/16	2	2
N/R	N/R	N/R	N/R	N/R	N/R	N/R	N/R	N/R	1-1/25	1-1/16	1-7/25	1-7/16
N/R	N/R	N/R	N/R	N/R	N/R	N/R	N/R	N/R	1-1/33	1-1/16	1-1/4	1-7/25
Black	108-92-2	108-91-2	108-90-2	108-90-2	108-27-2	134-110	N/A	N/S	1-13/64	1-13/32	1-3/8	2
Black	108-92-2	108-91-2	108-90-2	108-90-2	108-27-2	134-110	N/A	N/S	1-13/64	1-13/32	1-3/8	2
0.025	108-83-2	108-89-2	108-83-2	108-89-2	N/R	N/S	N/S	N/S	1-1/16	1-1/16	1-7/16	1-7/16
0.025	108-83-2	108-89-2	108-83-2	108-89-2	N/R	N/S	N/S	N/S	1-1/16	1-1/16	1-7/16	1-7/16
Purple	108-83-2	108-91-2	108-90-2	108-90-2	108-27-2	N/S	N/S	N/S	1-1/4	1-5/16	1-9/16	1-9/16
N/R	108-83-2	108-89-2	N/R	N/R	N/R	134-103	N/R	N/A	1-3/16	N/R	1-1/2	N/R
N/R	108-83-2	108-89-2	N/R	N/R	N/R	134-103	N/R	N/A	1-3/16	N/R	1-1/2	N/R
N/R	N/S	N/R	N/R	N/R	N/R	N/R	N/R	N/S	1-1/16	1-3/16	1-3/8	1-7/16
N/R	N/S	N/R	N/R	N/R	N/R	N/R	N/R	N/S	1-1/16	1-3/16	1-3/8	1-7/16
N/R	N/S	N/R	N/R	N/R	N/R	N/R	N/R	N/S	1-1/16	1-3/16	1-3/8	1-7/16
N/R	N/S	N/R	N/R	N/R	N/R	N/R	N/R	N/S	1-1/16	1-3/16	1-3/8	1-7/16
N/R	N/S	N/R	N/R	N/R	N/R	N/R	N/R	N/S	1-1/16	1-3/16	1-3/8	1-7/16
Plain	108-83-2	108-91-2	108-90-2	108-90-2	108-27-2	N/S	N/S	N/S	1-1/4	1-5/16	1-9/16	1-9/16
Plain	108-92-2	108-91-2	108-90-2	108-90-2	108-27-2	N/S	N/A	N/S	1-13/32	1-13/64	1-3/8	2
N/R	N/S	N/R	N/R	N/R	N/R	N/R	N/R	N/S	1-1/16	1-3/16	1-3/8	1-7/16
N/R	N/S	N/R	N/R	N/R	N/R	N/R	N/R	N/S	1-1/16	1-3/16	1-3/8	1-7/16
N/R	N/S	N/R	N/R	N/R	N/R	N/R	N/R	N/S	1-1/16	1-3/16	1-3/8	1-7/16
N/R	N/S	N/R	N/R	N/R	N/R	N/R	N/R	N/S	1-1/16	1-3/16	1-3/8	1-7/16
Black	108-83-2	108-91-2	108-90-2	108-90-2	108-27-2	134-101	134-105	N/S	1-1/4	1-5/16	1-9/16	1-9/16
Black	108-83-2	108-91-2	108-90-2	108-90-2	108-27-2	N/S	134-105	N/S	1-1/4	1-5/16	1-9/16	1-9/16
Black	108-83-2	108-91-2	108-90-2	108-90-2	108-27-2	N/S	134-105	N/S	1-1/4	1-5/16	1-9/16	1-9/16
N/R	N/S	N/R	N/R	N/R	N/R	N/R	N/R	N/S	1-1/16	1-3/16	1-3/8	1-7/16
N/R	N/S	N/R	N/R	N/R	N/R	N/R	N/R	N/S	1-1/16	1-3/16	1-3/8	1-7/16
N/R	N/S	N/R	N/R	N/R	N/R	N/R	N/R	N/S	1-1/16	1-3/16	1-3/8	1-7/16
Black	108-83-2	108-91-2	108-90-2	108-90-2	108-27-2	N/S	134-105	N/S	1-1/4	1-5/16	1-9/16	1-9/16
Black	108-83-2	108-91-2	108-90-2	108-90-2	108-27-2	N/S	134-105	N/S	1-1/4	1-5/16	1-9/16	1-9/16
Black	108-83-2	108-91-2	108-90-2	108-90-2	108-27-2	N/S	134-105	N/S	1-1/4	1-5/16	1-9/16	1-9/16
Plain	108-83-2	108-91-2	108-90-2	108-90-2	108-27-2	N/A	134-105	N/A	1-1/16	1-1/16	1-7/16	1-7/16
Black	108-92-2	108-91-2	108-90-2	108-90-2	108-27-2	134-110	N/A	N/S	1-13/64	1-13/32	1-3/8	2
Black	108-92-2	108-91-2	108-90-2	108-90-2	108-27-2	134-110	N/A	N/S	1-13/64	1-13/32	1-3/8	2
Black	108-92-2	108-91-2	108-90-2	108-90-2	108-27-2	134-110	N/A	N/S	1-13/64	1-13/32	1-3/8	2
Black	108-92-2	108-91-2	108-90-2	108-90-2	108-27-2	134-110	N/A	N/S	1-13/64	1-13/32	1-3/8	2
0.035	108-105	108-106	108-105	108-106	N/R	134-108	134-112	N/S	1-11/16	1-11/16	2	2
0.035	108-105	108-106	108-105	108-106	N/R	134-108	134-112	N/S	1-11/16	1-11/16	2	2

See pages 190 & 191 for numerical listing specific footnotes.

HOW TO CHOOSE A CARB
STREET CARBURETORS
SUPERCHARGER CARBURETORS
RACE CARBURETORS
MARINE CARBURETORS
CARB SERVICE PARTS & ACCESSORIES
FUEL INJECTION
THROTTLE BODIES
FUEL PUMPS
INTAKE MANIFOLDS
CYLINDER HEADS
SYSTEMAX
ENGINE DRESS-UP
MERCHANDISING
TECHNICAL INFORMATION
INDEX

180 TECHNICAL INFORMATION - Carburetor Numerical Listing

HOW TO CHOOSE A CARB	Carburetor Part No.	Carb. Model No.	CFM	Renew Kit	Trick Kit	Needle & Seal	Primary Main Jet	Secondary Main Jet or Plate	Primary Metering Block	Secondary Metering Block	Power Valve	Pump Nozzle Size, Primary
STREET CARBURETORS	R8082-2	4500	1050	37-1539	37-933	6-518-2	122-84	122-84	N/A	N/A	125-65 (15)	0.035
STREET CARBURETORS	R8082-3	4500	1050	37-1539	37-933	6-518-2	122-84	122-84	N/A	N/A	125-65 (15)	0.035
STREET CARBURETORS	R8149	4360	450	37-1540	N/A	N/S	124-231	124-550	N/R	N/R	N/S	0.028
STREET CARBURETORS	R8149-1	4360	450	37-1540	N/A	N/S	124-215	124-550	N/R	N/R	N/S	0.028
STREET CARBURETORS	R8156	4150	750	37-485	37-933	6-504	122-70	122-83	134-155	N/S	125-65	0.028
SUPERCHARGER CARBURETORS	R8158	4360	450	37-1540	N/A	N/S	124-219	124-550	N/R	N/R	N/S	0.028
SUPERCHARGER CARBURETORS	R8162	4150	850	37-485	37-933	6-504	122-80	122-80	N/A	N/S	125-65	0.031
SUPERCHARGER CARBURETORS	R8181	4160	600	37-1536	37-933	6-504	122-80	122-80	N/S	134-39	125-65 (15)	0.031
SUPERCHARGER CARBURETORS	R8203	4360	450	37-1540	N/A	N/S	124-211	124-550	N/R	N/R	N/S	0.028
SUPERCHARGER CARBURETORS	R8204	4360	450	37-1540	N/A	N/S	124-215	124-550	N/R	N/R	N/S	0.028
RACE CARBURETORS	R8206	4360	450	37-1540	N/A	N/S	124-203	124-550	N/R	N/R	N/S	0.028
RACE CARBURETORS	R8207	4160	600	N/A	N/A	6-506	122-622	134-39	N/S	N/S	125-85	0.031
RACE CARBURETORS	R8276	4175	650	37-1537	37-933	(16,17)	122-572	134-21	N/S	N/S	125-85	0.025
RACE CARBURETORS	R8302	4175	650	37-1537	37-933	(16,17)	122-582	134-21	N/S	N/S	125-85	0.025
MARINE CARBURETORS	R8479	4360	450	37-1540	N/A	N/S	124-219	124-589	N/R	N/R	N/S	0.028
MARINE CARBURETORS	R8516	4360	450	37-1540	N/A	N/S	124-167	124-423	N/R	N/R	N/S	0.028
MARINE CARBURETORS	R8517	4360	450	37-1540	N/A	N/S	124-203	124-524	N/R	N/R	N/S	0.028
CARB SERVICE PARTS & ACCESSORIES	R8546	4175	650	37-1537	37-933	(16,17)	122-582	134-21	N/S	134-21	125-85	0.025
CARB SERVICE PARTS & ACCESSORIES	R8642	4360	450	37-1540	N/A	N/S	124-215	124-500	N/R	N/R	N/S	0.028
CARB SERVICE PARTS & ACCESSORIES	R8677	4360	450	37-1540	N/A	N/S	124-219	124-524	N/R	N/R	N/S	0.028
FUEL INJECTION	R8679	4175	650	37-1537	37-933	(16,17)	122-592	34R9716-27	N/S	N/A	125-85	0.025
FUEL INJECTION	R8700	4175	650	37-1537	37-933	(16,17)	122-582	134-21	N/S	134-21	125-85	0.025
FUEL INJECTION	R8771	4360	450	37-1540	N/A	N/S	124-207	124-537	N/R	N/R	N/S	0.028
FUEL INJECTION	R8804	4150	830	37-485	37-933	6-504	122-80	122-80	N/S	N/S	125-65 (B)	0.028
FUEL INJECTION	R8874	4360	450	37-1540	N/A	N/S	124-219	124-589	N/R	N/R	N/S	0.028
THROTTLE BODIES	R8875	4360	450	3-1160	N/A	N/S	124-231	124-576	N/R	N/R	N/S	0.028
THROTTLE BODIES	R8876	4360	450	N/A	N/A	N/S	124-231	124-550	N/R	N/R	N/S	0.028
THROTTLE BODIES	R8877	4360	450	3-1160	N/A	N/S	124-231	124-550	N/R	N/R	N/S	0.028
THROTTLE BODIES	R8879	4175	650	37-1537	37-933	(16,17)	122-592	134-21	N/S	134-21	125-65	0.025
THROTTLE BODIES	R8896	4500	1050	37-1539	37-933	6-504	122-88	122-88	N/A	N/A	N/R	0.035
FUEL PUMPS	R8896-1	4500	1050	37-1539	37-933	6-518-2	122-88	122-88	N/A	N/A	125-55	0.035
FUEL PUMPS	R8896-2	4500	1050	37-1539	37-933	6-518-2	122-88	122-88	134-70	134-70	125-55	0.035
FUEL PUMPS	R8914	4360	450	37-1540	N/A	N/S	124-207	124-537	N/R	N/R	N/S	0.028
FUEL PUMPS	R8958	4360	450	37-1540	N/A	N/S	124-195	124-550	N/R	N/R	N/S	0.028
FUEL PUMPS	R9002	4160	600	37-1536	37-933	6-506	122-632	134-37	N/S	134-37	125-208	0.031
INTAKE MANIFOLDS	R9015-1	4160	750	3-720	N/A	6-504	122-76	34R9716-27	N/S	N/R	125-105	0.025
INTAKE MANIFOLDS	R9022	4150	800	3-485	N/A	6-504	122-72	122-87	N/S	N/S	125-65	0.031
INTAKE MANIFOLDS	R9040	4160	600	37-119	37-933	N/S	122-661	N/S	N/S	N/S	125-211	0.031
CYLINDER HEADS	R9088	4360	450	N/A	N/A	N/S	124-215	124-550	N/R	N/R	N/S	0.028
CYLINDER HEADS	R9105	4360	450	3-1160	N/A	N/S	124-195	124-550	N/R	N/R	N/S	0.028
CYLINDER HEADS	R9112	4360	450	37-1540	N/A	N/S	124-211	124-563	N/R	N/R	N/S	0.028
CYLINDER HEADS	R9162	4360	450	37-1540	N/A	N/S	124-203	124-537	N/R	N/R	N/S	0.028
CYLINDER HEADS	R9185	4360	450	37-1540	N/A	N/S	124-191	124-550	N/R	N/R	N/S	0.028
CYLINDER HEADS	R9188	4150	780	37-1539	37-933	6-504	122-72	122-76	N/S	N/S	(12,21)	0.025
CYLINDER HEADS	R9192	4360	450	37-1540	N/A	N/S	124-231	124-550	N/R	N/R	N/S	0.028
CYLINDER HEADS	R9193	4360	450	37-1540	N/A	N/S	124-211	124-589	N/R	N/R	N/S	0.028
ENGINE DRESS-UP	R9210	4160	600	37-1536	37-933	6-506	122-612	134-39	N/S	N/S	125-208	0.031
ENGINE DRESS-UP	R9219	4160	600	37-1536	37-933	6-506	122-632	134-39	N/S	134-39	125-208	0.031
ENGINE DRESS-UP	R9228	5200	280	N/A	N/A	N/S	124-163	124-231	N/R	N/R	N/S	0.023
ENGINE DRESS-UP	R9254	4160	600	37-1536	37-933	6-506	122-622	134-39	N/S	N/S	125-211	0.031
MERCHANDISING	R9375	4500	1050	37-1539	37-933	6-504	122-92	122-92	N/A	N/A	N/R	0.035
MERCHANDISING	R9375-1	4500	1050	37-1539	37-933	6-518-2	122-86	122-86	N/A	N/A	N/R	0.035
MERCHANDISING	R9375-2	4500	1050	37-1539	37-933	6-518-2	122-86	122-86	N/A	N/A	N/R	0.035
MERCHANDISING	R9377	4500	1150	37-1539	37-933	6-504	122-94	122-94	N/S	N/S	N/R	0.035
MERCHANDISING	R9377-1	4500	1150	37-1539	37-933	6-518-2	122-92	122-92	N/A	N/A	N/R	0.035
MERCHANDISING	R9377-2	4500	1150	37-1539	37-933	6-518-2	122-92	122-92	N/A	N/A	N/R	0.035
MERCHANDISING	R9379	4150	750	37-485	37-933	6-504	122-68	122-81	134-155	N/A	125-65	0.028

See pages 190 & 191 for numerical listing specific footnotes.

Secondary Nozzle Size or Spring Color	Primary Bowl Gasket*	Primary Metering Block Gasket	Secondary Bowl Gasket	Secondary Metering Block Gasket	Secondary Metering Plate Gasket	Primary Fuel Bowl	Secondary Fuel Bowl	Throttle Body & Shaft Assembly	Venturii Diameter Primary	Venturii Diameter Secondary	Throttle Bore Diameter Primary	Throttle Bore Diameter Secondary
0.035	108-83-2	108-89-2	108-83-2	108-89-2	N/R	134-108	134-112	N/S	1-11/16	1-11/16	2	2
0.035	108-83-2	108-89-2	108-83-2	108-89-2	N/R	134-108	134-112	N/S	1-11/16	1-11/16	2	2
N/R	N/S	N/R	N/R	N/R	N/R	N/R	N/R	N/S	1-1/16	1-3/16	1-3/8	1-7/16
N/R	N/S	N/R	N/R	N/R	N/R	N/R	N/R	N/S	1-1/16	1-3/16	1-3/8	1-7/16
0.031	108-83-2	108-89-2	108-83-2	108-89-2	N/R	134-103	134-104	N/A	1-3/8	1-3/8	1-11/16	1-11/16
N/R	N/S	N/R	N/R	N/R	N/R	N/R	N/R	N/S	1-1/16	1-3/16	1-3/8	1-7/16
0.031	108-83-2	108-89-2	108-83-2	108-89-2	N/R	134-103	134-104	N/A	1-9/16	1-9/16	1-3/4	1-3/4
0.031	108-83-2	108-89-2	108-83-2	108-89-2	N/R	N/A	134-105	N/S	1-9/16	1-9/16	1-3/4	1-3/4
N/R	N/S	N/R	N/R	N/R	N/R	N/R	N/R	N/S	1-1/16	1-3/16	1-3/8	1-7/16
N/R	N/S	N/R	N/R	N/R	N/R	N/R	N/R	N/S	1-1/16	1-3/16	1-3/8	1-7/16
N/R	N/S	N/R	N/R	N/R	N/R	N/R	N/R	N/S	1-1/16	1-3/16	1-3/8	1-7/16
Plain	108-83-2	108-91-2	108-90-2	108-90-2	108-27-2	N/S	N/S	N/S	1-1/4	1-5/16	1-9/16	1-9/16
Black	108-92-2	108-91-2	108-90-2	108-90-2	108-27-2	N/S	N/S	N/S	1-13/64	1-13/32	1-3/8	2
Black	108-92-2	108-91-2	108-90-2	108-90-2	108-27-2	N/S	N/S	N/S	1-13/64	1-13/32	1-3/8	2
N/R	N/S	N/R	N/R	N/R	N/R	N/R	N/R	N/S	1-1/16	1-3/16	1-3/8	1-7/16
N/R	N/S	N/R	N/R	N/R	N/R	N/R	N/R	N/S	1-1/16	1-3/16	1-3/8	1-7/16
N/R	N/S	N/R	N/R	N/R	N/R	N/R	N/R	N/S	1-1/16	1-3/16	1-3/8	1-7/16
Black	108-92-2	108-91-2	108-90-2	108-90-2	108-27-2	134-110	N/A	N/S	1-13/64	1-13/32	1-3/8	2
N/R	N/S	N/R	N/R	N/R	N/R	N/R	N/R	N/S	1-1/16	1-3/16	1-3/8	1-7/16
N/R	N/S	N/R	N/R	N/R	N/R	N/R	N/R	N/S	1-1/16	1-3/16	1-3/8	1-7/16
Plain	108-92-2	108-91-2	108-90-2	108-90-2	108-27-2	134-110	N/A	N/S	1-13/64	1-13/32	1-3/8	2
Black	108-92-2	108-91-2	108-90-2	108-90-2	108-27-2	134-110	N/A	N/S	1-13/64	1-13/32	1-3/8	2
N/R	N/S	N/R	N/R	N/R	N/R	N/R	N/R	N/S	1-1/16	1-3/16	1-3/8	1-7/16
0.028	108-83-2	108-89-2	108-83-2	108-89-2	N/R	134-103	134-104	N/A	1-9/16	1-9/16	1-11/16	1-11/16
N/R	N/S	N/R	N/R	N/R	N/R	N/R	N/R	N/S	1-1/16	1-3/16	1-3/8	1-7/16
N/R	N/S	N/R	N/R	N/R	N/R	N/R	N/R	N/S	1-1/16	1-3/16	1-3/8	1-7/16
N/R	N/S	N/R	N/R	N/R	N/R	N/R	N/R	N/S	1-1/16	1-3/16	1-3/8	1-7/16
Black	108-92-2	108-91-2	108-90-2	108-90-2	108-27-2	134-110	N/A	N/S	1-13/64	1-13/32	1-3/8	2
0.035	108-120	108-121	108-120	108-121	N/R	134-108	134-112	N/S	1-11/16	1-11/16	2	2
0.035	108-120	108-121	108-120	108-121	N/R	134-108	134-112	N/S	1-11/16	1-11/16	2	2
0.035	108-120	108-121	108-120	108-121	N/R	134-108	134-112	N/S	1-11/16	1-11/16	2	2
N/R	N/S	N/R	N/R	N/R	N/R	N/R	N/R	N/S	1-1/16	1-3/16	1-3/8	1-7/16
N/R	N/S	N/R	N/R	N/R	N/R	N/R	N/R	N/S	1-1/16	1-3/16	1-3/8	1-7/16
Black	108-83-2	108-91-2	108-90-2	108-90-2	108-27-2	N/A	134-105	N/S	1-1/4	1-5/16	1-9/16	1-9/16
Plain	N/A	N/A	N/A	N/A	108-27-2	N/S	N/S	N/S	1-3/8	1-7/16	1-11/16	1-11/16
0.031	N/A	N/A	N/A	N/A	N/R	N/S	N/S	N/S	1-3/8	1-7/16	1-11/16	1-11/16
Plain	108-83-2	108-91-2	108-90-2	108-90-2	108-27-2	N/S	134-105	N/S	1-1/4	1-5/16	1-9/16	1-9/16
N/R	N/S	N/R	N/R	N/R	N/R	N/R	N/R	N/S	1-1/16	1-3/16	1-3/8	1-7/16
N/R	N/S	N/R	N/R	N/R	N/R	N/R	N/R	N/S	1-1/16	1-3/16	1-3/8	1-7/16
N/R	N/S	N/R	N/R	N/R	N/R	N/R	N/R	N/S	1-1/16	1-3/16	1-3/8	1-7/16
N/R	N/S	N/R	N/R	N/R	N/R	N/R	N/R	N/S	1-1/16	1-3/16	1-3/8	1-7/16
Plain	108-83-2	108-89-2	108-83-2	108-89-2	N/R	N/S	N/S	N/S	1-3/8	1-7/16	1-11/16	1-11/16
N/R	N/S	N/R	N/R	N/R	N/R	N/R	N/R	N/S	1-1/16	1-3/16	1-3/8	1-7/16
N/R	N/S	N/R	N/R	N/R	N/R	N/R	N/R	N/S	1-1/16	1-3/16	1-3/8	1-7/16
N/R	N/S	N/R	N/R	N/R	N/R	N/R	N/R	N/S	1-1/16	1-3/16	1-3/8	1-7/16
Black	108-83-2	108-91-2	108-90-2	108-90-2	108-27-2	N/S	N/S	N/S	1-1/4	1-5/16	1-9/16	1-9/16
Black	108-83-2	108-91-2	108-90-2	108-90-2	108-27-2	N/S	134-105	N/S	1-1/4	1-5/16	1-9/16	1-9/16
N/R	N/R	N/R	N/R	N/R	N/R	N/R	N/R	N/R	1-1/25	1-1/16	1-7/25	1-7/16
Black	108-83-2	108-91-2	108-90-2	108-90-2	108-27-2	N/S	N/S	N/S	1-1/4	1-5/16	1-9/16	1-9/16
0.035	108-120	108-121	108-120	108-121	N/R	134-108	134-112	N/S	1-11/16	1-11/16	2	2
0.035	108-120	108-121	108-120	108-121	N/R	134-108	134-112	N/S	1-11/16	1-11/16	2	2
0.035	108-120	108-121	108-120	108-121	N/R	134-108	134-112	N/S	1-11/16	1-11/16	2	2
0.035	108-120	108-121	108-120	108-121	N/R	134-108	134-112	N/S	1-13/16	1-13/16	2	2
0.037	108-120	108-121	108-120	108-121	N/R	134-108	134-112	N/S	1-13/16	1-13/16	2	2
0.037	108-120	108-121	108-120	108-121	N/R	134-108	134-112	N/S	1-13/16	1-13/16	2	2
0.031	108-83-2	108-89-2	108-83-2	108-89-2	N/R	134-103	134-104	N/A	1-3/8	1-3/8	1-11/16	1-11/16

See pages 190 & 191 for numerical listing specific footnotes.

HOW TO CHOOSE A CARB
STREET CARBURETORS
SUPERCHARGER CARBURETORS
RACE CARBURETORS
MARINE CARBURETORS
CARB SERVICE PARTS & ACCESSORIES
FUEL INJECTION
THROTTLE BODIES
FUEL PUMPS
INTAKE MANIFOLDS
CYLINDER HEADS
SYSTEMAX
ENGINE DRESS-UP
MERCHANDISING
TECHNICAL INFORMATION
INDEX

182 TECHNICAL INFORMATION - Carburetor Numerical Listing

HOW TO CHOOSE A CARB	Carburetor Part No.	Carb. Model No.	CFM	Renew Kit	Trick Kit	Needle & Seal	Primary Main Jet	Secondary Main Jet or Plate	Primary Metering Block	Secondary Metering Block	Power Valve	Pump Nozzle Size, Primary
STREET CARBURETORS	R9379-1	4150	750	37-485	37-933	6-504	122-68	122-81	134-155	N/A	125-65	0.028
STREET CARBURETORS	R9380	4150	850	37-485	37-933	6-504	122-78	122-78	N/A	N/S	125-65 (15)	0.031
STREET CARBURETORS	R9380-1	4150	850	37-485	37-933	6-504	122-78	122-78	N/A	N/S	125-65 (15)	0.031
STREET CARBURETORS	R9381	4150	830	37-485	37-933	6-504	122-78	122-78	N/A	N/S	125-65 (15)	0.028
SUPERCHARGER CARBURETORS	R9429	5200	280	N/A	N/A	N/S	124-183	124-231	N/R	N/R	N/S	0.023
SUPERCHARGER CARBURETORS	R9441	5200	280	N/A	N/A	N/S	124-163	124-231	N/R	N/R	N/S	0.023
SUPERCHARGER CARBURETORS	R9444	5200	280	N/A	N/A	N/S	124-163	124-231	N/R	N/R	N/S	0.023
SUPERCHARGER CARBURETORS	R9446	5200	280	N/A	N/A	N/S	124-163	124-231	N/R	N/R	N/S	0.023
SUPERCHARGER CARBURETORS	R9545	5200	280	N/A	N/A	N/S	124-183	124-231	N/R	N/R	N/S	0.023
SUPERCHARGER CARBURETORS	R9626	4160	600	3-1415	N/A	6-506	122-612	134-39	N/S	N/S	125-206	0.031
RACE CARBURETORS	R9644	6520	280	N/A	N/A	N/A	124-179	124-283	N/R	N/R	N/A	0.02
RACE CARBURETORS	R9645	4150	750	37-1539	37-933	6-515-2	122-80	122-80	N/A	N/A	125-165 (15)	0.045
RACE CARBURETORS	R9646	4150	850	37-1539	37-933	6-515-2	122-92	122-92	N/A	N/A	125-165 (15)	0.045
RACE CARBURETORS	R9647	2300	500	37-1536	37-933	6-515-2	122-81	N/R	N/A	N/R	125-145	0.04
MARINE CARBURETORS	R9655	6520	280	N/A	N/A	N/A	124-195	124-299	N/R	N/R	N/A	0.02
MARINE CARBURETORS	R9659	6520	280	N/A	N/A	N/A	124-131	124-267	N/R	N/R	N/A	0.02
MARINE CARBURETORS	R9678	4360	450	3-1160	N/A	N/S	124-211	124-550	N/R	N/R	N/S	0.028
CARB SERVICE PARTS & ACCESSORIES	R9681	5200	280	N/A	N/A	N/S	124-171	124-215	N/R	N/R	N/S	0.023
CARB SERVICE PARTS & ACCESSORIES	R9682	6520	280	N/A	N/A	N/A	124-219	124-283	N/R	N/R	N/A	0.02
CARB SERVICE PARTS & ACCESSORIES	R9688	5200	280	N/A	N/A	N/S	124-163	124-251	N/R	N/R	N/S	0.023
FUEL INJECTION	R9689	5200	280	N/A	N/A	N/S	124-159	124-251	N/R	N/R	N/S	0.023
FUEL INJECTION	R9694	4360	450	37-1540	N/A	N/S	124-171	124-485	N/R	N/R	N/S	0.028
FUEL INJECTION	R9767	5200	280	N/A	N/A	N/S	124-179	124-259	N/R	N/R	N/S	0.023
FUEL INJECTION	R9776	4160	450	37-1536	37-933	6-506	122-582	N/A	N/S	N/A	125-85	0.031
FUEL INJECTION	R9777	4360	450	37-1540	N/A	N/S	124-255	124-550	N/R	N/R	N/S	0.028
THROTTLE BODIES	R9781	5200	280	N/A	N/A	N/S	124-159	124-251	N/R	N/R	N/S	0.023
THROTTLE BODIES	R9810	6520	280	N/A	N/A	N/A	124-195	124-299	N/R	N/R	N/A	0.02
THROTTLE BODIES	R9811	6520	280	N/A	N/A	N/A	124-155	124-271	N/R	N/R	N/A	0.02
THROTTLE BODIES	R9834	4160	600	37-720	37-933	6-506	122-642	134-39	N/S	134-39	125-65	0.031
THROTTLE BODIES	R9834-1	4160	600	37-720	37-933	6-506	122-661	134-39	N/S	134-39	125-65	0.031
FUEL PUMPS	R9834-2	4160	600	37-720	37-933	6-506	122-68	134-39	N/S	134-39	125-65	0.031
FUEL PUMPS	R9834-3	4160	600	37-720	37-933	6-506	122-68	134-39	N/S	134-39	125-65	0.031
FUEL PUMPS	R9864	5200	280	N/A	N/A	N/S	124-159	124-219	N/R	N/R	N/S	0.023
FUEL PUMPS	R9875	4360	450	N/A	N/A	N/S	124-199	124-576	N/R	N/R	N/S	0.028
FUEL PUMPS	R9895	4175	650	37-1537	37-933	(16,17)	122-592	134-21	N/S	134-21	125-206	0.037
FUEL PUMPS	R9895-1	4175	650	37-1537	37-933	(16,17)	122-592	134-21	N/S	134-21	125-206	0.037
INTAKE MANIFOLDS	R9896	6510	280	N/A	N/A	N/A	124-104	124-271	N/R	N/R	N/A	0.02
INTAKE MANIFOLDS	R9899	5200	280	N/A	N/A	N/S	124-147	124-231	N/R	N/R	N/S	0.023
CYLINDER HEADS	R9923	4175	650	37-1537	37-933	(16,17)	122-542	N/S	N/S	N/S	125-211	0.025
CYLINDER HEADS	R9925	5200	280	N/A	N/A	N/S	124-147	124-251	N/R	N/R	N/S	0.023
CYLINDER HEADS	R9931	4360	450	37-1540	N/A	N/S	124-239	124-550	N/R	N/R	N/S	0.028
CYLINDER HEADS	R9932	5200	280	N/A	N/A	N/S	124-159	124-219	N/R	N/R	N/S	0.023
CYLINDER HEADS	R9935	4360	450	37-1540	N/A	N/S	124-207	124-589	N/R	N/R	N/S	0.028
CYLINDER HEADS	R9948	4175	650	37-1537	37-933	(16,17)	122-563	N/S	N/S	N/S	125-211	0.025
CYLINDER HEADS	R9973	4360	450	37-1540	N/A	N/S	124-171	124-330	N/R	N/R	N/S	0.028
CYLINDER HEADS	R9976	4175	650	37-1537	37-933	(16,17)	122-582	N/S	N/S	N/S	125-211	0.025
ENGINE DRESS-UP	R50399	4160	650	703-28	N/A	6-511	122-73	N/S	N/S	N/R	125-65	0.04
ENGINE DRESS-UP	R50399-1	4160	650	703-28	N/A	N/S	122-73	N/S	N/S	N/R	125-65	0.04
MERCHANDISING	R80054	5200	280	N/A	N/A	N/S	124-231	124-247	N/R	N/R	N/S	0.023
MERCHANDISING	R80055	5200	280	N/A	N/A	N/S	124-231	124-247	N/R	N/R	N/S	0.023
MERCHANDISING	R80056	5200	280	N/A	N/A	N/S	124-231	124-247	N/R	N/R	N/S	0.023
MERCHANDISING	R80057	5200	280	N/A	N/A	N/S	124-132	124-135	N/R	N/R	N/S	0.023
MERCHANDISING	R80073	4175	650	N/A	N/A	(16,17)	122-642	N/S	N/S	N/S	125-213	0.037
MERCHANDISING	R80086	4360	450	N/A	N/A	N/S	124-199	124-550	N/R	N/R	N/S	0.028
MERCHANDISING	R80095	2305	500	37-1536	37-933	6-504	122-55	122-73	N/S	N/R	125-85	0.035
TECHNICAL INFORMATION	R80098	4180	600	37-1536	37-933	6-517	122-612	N/S	N/S	N/S	125-215	0.028
TECHNICAL INFORMATION	R80099	4180	600	37-1536	37-933	6-517	122-622	N/S	N/S	N/S	125-218	0.028

See pages 190 & 191 for numerical listing specific footnotes.

Secondary Nozzle Size or Spring Color	Primary Bowl Gasket	Primary Metering Block Gasket	Secondary Bowl Gasket	Secondary Metering Block Gasket	Secondary Metering Plate Gasket	Primary Fuel Bowl	Secondary Fuel Bowl	Throttle Body & Shaft Assembly	Venturii Diameter Primary	Venturii Diameter Secondary	Throttle Bore Diameter Primary	Throttle Bore Diameter Secondary
0.031	108-83-2	108-89-2	108-83-2	108-89-2	N/R	134-103	134-104	N/A	1-3/8	1-3/8	1-11/16	1-11/16
0.031	108-83-2	108-89-2	108-83-2	108-89-2	N/R	134-103	134-104	N/A	1-9/16	1-9/16	1-3/4	1-3/4
0.031	108-83-2	108-89-2	108-83-2	108-89-2	N/R	134-103	134-104	N/A	1-9/16	1-9/16	1-3/4	1-3/4
0.028	108-83-2	108-89-2	108-83-2	108-89-2	N/R	134-103	134-104	N/A	1-9/16	1-9/16	1-11/16	1-11/16
N/R	N/R	N/R	N/R	N/R	N/R	N/R	N/R	N/R	1-1/25	1-1/16	1-7/25	1-7/16
N/R	N/R	N/R	N/R	N/R	N/R	N/R	N/R	N/R	1-1/25	1-1/16	1-7/25	1-7/16
N/R	N/R	N/R	N/R	N/R	N/R	N/R	N/R	N/R	1-1/25	1-1/16	1-7/25	1-7/16
N/R	N/R	N/R	N/R	N/R	N/R	N/R	N/R	N/R	1-1/25	1-1/16	1-7/25	1-7/16
Black	108-83-2	108-91-2	108-90-2	108-90-2	108-27-2	N/S	N/S	N/S	1-1/4	1-5/16	1-9/16	1-9/16
N/R	N/R	N/R	N/R	N/R	N/R	N/R	N/R	N/R	1-1/25	1-1/16	1-7/25	1-7/16
0.045	108-83-2	108-89-2	108-83-2	108-89-2	N/R	134-103	134-104	N/A	1-3/8	1-3/8	1-11/16	1-11/16
0.045	108-83-2	108-89-2	108-83-2	108-89-2	N/R	134-103	134-104	N/S	1-9/16	1-9/16	1-3/4	1-3/4
N/R	108-83-2	108-89-2	N/R	N/R	N/R	134-103	N/S	112-2	1-3/8	N/R	1-11/16	N/R
N/R	N/R	N/R	N/R	N/R	N/R	N/R	N/R	N/R	1-1/25	1-1/16	1-7/25	1-7/16
N/R	N/R	N/R	N/R	N/R	N/R	N/R	N/R	N/R	1-1/25	1-1/16	1-7/25	1-7/16
N/R	N/S	N/R	N/R	N/R	N/R	N/R	N/R	N/S	1-1/16	1-3/16	1-3/8	1-7/16
N/R	N/R	N/R	N/R	N/R	N/R	N/R	N/R	N/R	1-1/25	1-1/16	1-7/25	1-7/16
N/R	N/R	N/R	N/R	N/R	N/R	N/R	N/R	N/R	1-1/25	1-1/16	1-7/25	1-7/16
N/R	N/R	N/R	N/R	N/R	N/R	N/R	N/R	N/R	1-1/25	1-1/16	1-7/25	1-7/16
N/R	N/R	N/R	N/R	N/R	N/R	N/R	N/R	N/R	1-1/25	1-1/16	1-7/25	1-7/16
N/R	N/R	N/R	N/R	N/R	N/R	N/R	N/R	N/R	1-1/25	1-1/16	1-7/25	1-7/16
N/R	N/S	N/R	N/R	N/R	N/R	N/R	N/R	N/R	1-1/16	1-3/16	1-3/8	1-7/16
N/R	N/R	N/R	N/R	N/R	N/R	N/R	N/R	N/R	1-1/25	1-1/16	1-7/25	1-7/16
N/R	108-83-2	108-89-2	108-90-2	108-90-2	108-27-2	134-101	134-105	N/A	1-3/32	1-3/32	1-1/2	1-1/2
N/R	N/S	N/R	N/R	N/R	N/R	N/R	N/R	N/R	1-1/16	1-3/16	1-3/8	1-7/16
N/R	N/R	N/R	N/R	N/R	N/R	N/R	N/R	N/R	1-1/25	1-1/16	1-7/25	1-7/16
N/R	N/R	N/R	N/R	N/R	N/R	N/R	N/R	N/R	1-1/25	1-1/16	1-7/25	1-7/16
N/R	N/R	N/R	N/R	N/R	N/R	N/R	N/R	N/R	1-1/25	1-1/16	1-7/25	1-7/16
Black	108-83-2	108-91-2	108-90-2	108-90-2	108-27-2	N/A	134-105	N/S	1-1/4	1-5/16	1-9/16	1-9/16
Black	108-83-2	108-91-2	108-90-2	108-90-2	108-27-2	N/A	134-105	N/S	1-1/4	1-5/16	1-9/16	1-9/16
Black	108-83-2	108-91-2	108-90-2	108-90-2	108-27-2	N/A	134-105	N/S	1-1/4	1-5/16	1-9/16	1-9/16
Black	108-83-2	108-91-2	108-90-2	108-90-2	108-27-2	N/A	134-105	N/S	1-1/4	1-5/16	1-9/16	1-9/16
Black	108-83-2	108-91-2	108-90-2	108-90-2	108-27-2	N/A	134-105	N/S	1-1/4	1-5/16	1-9/16	1-9/16
Black	108-83-2	108-91-2	108-90-2	108-90-2	108-27-2	N/A	134-105	N/S	1-1/4	1-5/16	1-9/16	1-9/16
N/R	N/R	N/R	N/R	N/R	N/R	N/R	N/R	N/R	1-1/25	1-1/16	1-7/25	1-7/16
N/R	N/S	N/R	N/R	N/R	N/R	N/R	N/R	N/R	1-1/16	1-3/16	1-3/8	1-7/16
Black	108-92-2	108-91-2	108-90-2	108-90-2	108-27-2	134-110	N/A	N/A	1-13/64	1-13/32	1-3/8	2
Black	108-92-2	108-91-2	108-90-2	108-90-2	108-27-2	134-110	N/A	N/A	1-13/64	1-13/32	1-3/8	2
N/R	N/R	N/R	N/R	N/R	N/R	N/R	N/R	N/R	1-1/25	1-1/16	1-7/25	1-7/16
N/R	N/R	N/R	N/R	N/R	N/R	N/R	N/R	N/R	1-1/25	1-1/16	1-7/25	1-7/16
Black	108-92-2	108-91-2	108-90-2	108-90-2	108-27-2	N/S	N/S	N/S	1-13/64	1-13/32	1-3/8	2
N/R	N/R	N/R	N/R	N/R	N/R	N/R	N/R	N/R	1-1/25	1-1/16	1-7/25	1-7/16
N/R	N/S	N/R	N/R	N/R	N/R	N/R	N/R	N/S	1-1/16	1-3/16	1-3/8	1-7/16
N/R	N/R	N/R	N/R	N/R	N/R	N/R	N/R	N/R	1-1/25	1-1/16	1-7/25	1-7/16
N/R	N/S	N/R	N/R	N/R	N/R	N/R	N/R	N/S	1-1/16	1-3/16	1-3/8	1-7/16
Black	108-92-2	108-91-2	108-90-2	108-90-2	108-27-2	N/S	N/S	N/S	1-13/64	1-13/32	1-3/8	2
N/R	N/S	N/R	N/R	N/R	N/R	N/R	N/R	N/S	1-1/16	1-3/16	1-3/8	1-7/16
Black	108-92-2	108-91-2	108-90-2	108-90-2	108-27-2	N/S	N/A	N/S	1-13/64	1-13/32	1-3/8	2
White	108-83-2	108-91-2	108-90-2	108-90-2	108-13-2	N/S	N/S	N/S	1-1/4	1-5/16	1-9/16	1-9/16
White	108-83-2	108-91-2	108-90-2	108-90-2	108-13-2	N/S	N/S	N/S	1-1/4	1-5/16	1-9/16	1-9/16
N/R	N/S	N/R	N/R	N/R	N/R	N/R	N/R	N/R	1-1/25	1-1/16	1-7/25	1-7/16
N/R	N/S	N/R	N/R	N/R	N/R	N/R	N/R	N/R	1-1/25	1-1/16	1-7/25	1-7/16
N/R	N/S	N/R	N/R	N/R	N/R	N/R	N/R	N/R	1-1/25	1-1/16	1-7/25	1-7/16
N/R	N/S	N/R	N/R	N/R	N/R	N/R	N/R	N/R	1-1/25	1-1/16	1-7/25	1-7/16
Black	34-202	108-91-2	108-90-2	108-90-2	108-27-2	N/S	N/S	N/S	1-13/64	1-13/32	1-3/8	2
N/R	N/S	N/R	N/R	N/R	N/R	N/R	N/R	N/R	1-1/16	1-3/16	1-3/8	1-7/16
0.028	108-83-2	108-89-2	N/R	N/R	N/R	N/R	N/R	N/R	1-3/8	1-3/8	1-11/16	1-11/16
Purple	108-56-2	108-55-2	108-90-2	108-90-2	108-13-2	N/S	N/S	N/S	1-1/4	1-5/16	1-9/16	1-9/16
Purple	108-56-2	108-55-2	108-90-2	108-90-2	108-13-2	N/S	N/S	N/S	1-1/4	1-5/16	1-9/16	1-9/16

See pages 190 & 191 for numerical listing specific footnotes.

HOW TO CHOOSE A CARB
STREET CARBURETORS
SUPERCHARGER CARBURETORS
RACE CARBURETORS
MARINE CARBURETORS
CARB SERVICE PARTS & ACCESSORIES
FUEL INJECTION
THROTTLE BODIES
FUEL PUMPS
INTAKE MANIFOLDS
CYLINDER HEADS
SYSTEMAX
ENGINE DRESS-UP
MERCHANDISING
TECHNICAL INFORMATION
INDEX

HOW TO CHOOSE A CARB	Carburetor Part No.	Carb. Model No.	CFM	Renew Kit	Trick Kit	Needle & Seal	Primary Main Jet	Secondary Main Jet or Plate	Primary Metering Block	Secondary Metering Block	Power Valve	Pump Nozzle Size, Primary
STREET CARBURETORS	R80111	4180	600	37-1536	37-933	6-517	122-612	N/S	N/S	N/S	125-216	0.028
STREET CARBURETORS	R80112	4180	600	37-1536	37-933	6-517	122-622	N/S	N/S	N/S	125-217	0.028
STREET CARBURETORS	R80120	2305	350	37-1536	37-933	6-504	122-52	122-65	N/S	N/R	125-85	0.035
STREET CARBURETORS	R80128	4175	650	37-1537	37-933	6-510	122-582	N/S	N/S	N/S	125-211	0.031
STREET CARBURETORS	R80133	4180	600	37-1536	37-933	6-517	122-611	N/S	N/S	N/S	125-216	0.028
SUPERCARGER CARBURETORS	R80134	4180	600	37-1536	37-933	6-517	122-612	N/S	N/S	N/S	N/S	0.028
SUPERCARGER CARBURETORS	R80135	4180	600	37-1536	37-933	6-517	122-612	N/S	N/S	N/S	N/S	0.028
SUPERCARGER CARBURETORS	R80136	4180	600	37-1536	37-933	6-517	122-612	N/S	N/S	N/S	N/S	0.028
SUPERCARGER CARBURETORS	R80137	4180	600	37-1536	37-933	6-517	122-612	N/S	N/S	N/S	N/S	0.028
SUPERCARGER CARBURETORS	R80139	4175	650	37-1537	37-933	6-510	122-592	134-21	N/S	N/S	N/S	0.037
RACE CARBURETORS	R80140	4175	650	N/A	N/A	6-510	122-642	N/S	N/S	N/S	125-213	0.037
RACE CARBURETORS	R80145	4150	600	37-1539	37-933	6-504	122-68	122-70	N/S	N/S	125-65	0.031
RACE CARBURETORS	R80155	4175	650	37-1537	37-933	6-510	122-632	134-21	N/S	N/S	N/S	0.037
MARINE CARBURETORS	R80163	4180	600	37-1536	37-933	6-517	122-622	N/S	N/S	N/S	N/S	0.028
MARINE CARBURETORS	R80164	4180	600	37-1536	37-933	6-517	122-612	N/S	N/S	N/S	N/S	0.028
MARINE CARBURETORS	R80165	4180	600	37-1536	37-933	6-517	122-612	N/S	N/S	N/S	N/S	0.028
MARINE CARBURETORS	R80166	4180	600	37-1536	37-933	6-517	122-612	N/S	N/S	N/S	N/S	0.028
MARINE CARBURETORS	R80169	4175	650	37-1537	37-933	6-510	122-543	N/A	N/S	N/S	125-211	0.025
MARINE CARBURETORS	R80186	4500	750	37-1539	37-933	6-504	122-70	122-70	N/S	N/S	125-65 (15)	0.028
MARINE CARBURETORS	R80186-1	4500	750	37-1539	37-933	6-518-2	122-70	122-70	N/S	N/S	125-65 (15)	0.028
MARINE CARBURETORS	R80186-2	4500	750	37-1539	37-933	6-518-2	122-70	122-70	N/S	N/S	125-65 (15)	0.028
FUEL INJECTION	R80318-1	4160	600	703-33	N/A	N/S	122-74	N/S	N/S	N/S	125-65	0.04
FUEL INJECTION	R80319-1	4160	600	703-47	N/A	6-511	122-65	N/S	N/S	N/S	125-25	0.025
FUEL INJECTION	R80319-2	4160	600	703-47	N/A	6-511	122-65	N/S	N/S	N/S	125-25	0.025
FUEL INJECTION	R80319-3	4160	600	703-47	N/A	6-511	122-65	N/S	N/S	N/S	125-25	0.025
FUEL INJECTION	R80319-4	4160	600	703-47	N/A	6-511	122-65	N/S	N/S	N/S	125-25	0.025
THROTTLE BODIES	R80320-1	2300	350	703-30	N/A	N/S	122-61	N/R	N/S	N/R	125-50	0.028
THROTTLE BODIES	R80320-2	2300	350	703-30	N/A	N/S	122-61	N/R	N/S	N/R	125-50	0.028
THROTTLE BODIES	R80340-1	4500	1050	37-1539	37-933	6-504	122-84	122-84	N/S	N/S	125-65 (15)	0.035
THROTTLE BODIES	R80340-2	4500	1050	37-1539	37-933	6-518-2	122-88	122-88	N/S	N/S	125-65 (15)	0.035
FUEL PUMPS	R80364	4150	450	703-28	N/A	6-511	122-59	N/S	N/S	N/S	125-85	0.021
FUEL PUMPS	R80364-1	4150	450	703-28	N/A	6-511	122-59	N/S	N/S	N/S	125-85	0.021
FUEL PUMPS	R80402-1	2300	500	703-36	N/A	6-511	122-75	N/R	N/S	N/R	125-45	0.028
INTAKE MANIFOLDS	R80431	4160	550	37-119	37-933	6-506	122-60	134-9	N/S	N/S	125-65	0.025
INTAKE MANIFOLDS	R80432	4160	550	37-119	37-933	6-506	122-60	134-9	N/S	N/S	125-65	0.025
INTAKE MANIFOLDS	R80436	4150	850	37-1539	37-933	6-504	122-80	122-80	N/S	N/A	125-65 (22)	0.04
INTAKE MANIFOLDS	R80443	4150	850	703-58	N/A	6-504	122-88	122-96	N/S	N/S	125-65 (15)	0.031
INTAKE MANIFOLDS	R80450	4160	600	37-1536	37-933	6-506	122-622	134-39	N/S	N/S	125-208	0.031
INTAKE MANIFOLDS	R80451	4160	600	37-1536	37-933	6-506	122-622	134-39	N/S	N/S	125-208	0.031
INTAKE MANIFOLDS	R80452	4160	600	37-1536	37-933	6-506	122-652	134-39	N/S	N/S	125-208	0.031
INTAKE MANIFOLDS	R80453	4160	600	37-1536	37-933	6-506	122-632	134-39	N/S	N/S	125-208	0.031
INTAKE MANIFOLDS	R80454	4160	600	37-1536	37-933	6-506	122-622	134-39	N/S	N/S	125-208	0.031
INTAKE MANIFOLDS	R80457	4160	600	37-119	37-933	6-506	122-69	134-39	134-128	134-39	125-65	0.031
INTAKE MANIFOLDS	R80457-1	4160	600	37-119	37-933	6-506	122-64	134-39	134-128	134-39	125-65	0.031
INTAKE MANIFOLDS	R80457-2	4160	600	37-119	37-933	6-506	122-64	134-39	134-128S	134-39	125-65	0.031
INTAKE MANIFOLDS	R80457-3	4160	600	37-119	37-933	6-506	122-64	134-39	134-128S	134-39	125-65	0.031
INTAKE MANIFOLDS	R80457-4	4160	600	37-119	37-933	6-506	122-64	134-39	134-128S	134-39	125-65	0.031
INTAKE MANIFOLDS	R80457-5	4160	600	37-119	37-933	6-511	122-64	134-39	134-128S	134-39	125-65	0.031
INTAKE MANIFOLDS	R80457-6	4160	600	37-119	37-933	6-506	122-64	134-39	134-128S	134-39	125-65	0.031
INTAKE MANIFOLDS	R80457-7	4160	600	37-119	37-933	6-511	122-64	134-39	134-128S	134-39	125-65	0.031
INTAKE MANIFOLDS	R80460	4160	600	37-1536	37-933	6-506	122-622	134-39	N/S	N/S	125-208	0.031
INTAKE MANIFOLDS	R80491	4175	650	37-1537	37-933	6-511	122-632	134-21	N/S	134-21	N/S	0.037
INTAKE MANIFOLDS	R80492	4160	600	703-29	N/A	6-511	122-68	N/S	N/S	N/S	N/A	0.037
INTAKE MANIFOLDS	R80492-1	4160	600	703-29	N/A	6-511	122-68	N/S	N/S	N/S	N/A	0.037
INTAKE MANIFOLDS	R80496	4150	950	37-1539	37-933	6-518-2	122-79	122-79	N/A	N/A	125-165 (both)	0.031
INTAKE MANIFOLDS	R80496-1	4150	950	37-1539	37-933	6-518-2	122-79	122-79	134-69	134-69	125-165 (both)	0.031
INTAKE MANIFOLDS	R80497	4150	950	37-1539	37-933	6-518-2	122-78	122-78	N/A	N/A	125-165 (both)	0.031

See pages 190 & 191 for numerical listing specific footnotes.

Secondary Nozzle Size or Spring Color	Primary Bowl Gasket	Primary Metering Block Gasket	Secondary Bowl Gasket	Secondary Metering Block Gasket	Secondary Metering Plate Gasket	Primary Fuel Bowl	Secondary Fuel Bowl	Throttle Body & Shaft Assembly	Venturii Diameter Primary	Venturii Diameter Secondary	Throttle Bore Diameter Primary	Throttle Bore Diameter Secondary
Orange	108-56-2	108-55-2	108-90-2	108-90-2	108-13-2	N/S	N/S	N/S	1-1/4	1-5/16	1-9/16	1-9/16
Orange	108-56-2	108-55-2	108-90-2	108-90-2	108-13-2	N/S	N/S	N/S	1-1/4	1-5/16	1-9/16	1-9/16
0.028	108-83-2	108-89-2	N/R	N/R	N/R	N/S	N/S	N/S	1-3/16	1-3/16	1-11/16	1-11/16
White	108-92-2	108-91-2	108-90-2	108-90-2	108-27-2	N/S	N/S	N/S	1-13/32	1-13/64	1-3/8	2
Orange	108-56-2	108-55-2	108-90-2	108-90-2	108-13-2	N/S	N/S	N/S	1-1/4	1-5/16	1-9/16	1-9/16
Brown	108-56-2	108-55-2	108-90-2	108-90-2	108-13-2	N/S	N/S	N/S	1-1/4	1-5/16	1-9/16	1-9/16
Brown	108-56-2	108-55-2	108-90-2	108-90-2	108-13-2	N/S	N/S	N/S	1-1/4	1-5/16	1-9/16	1-9/16
Brown	108-56-2	108-55-2	108-90-2	108-90-2	108-13-2	N/S	N/S	N/S	1-1/4	1-5/16	1-9/16	1-9/16
Brown	108-56-2	108-55-2	108-90-2	108-90-2	108-13-2	N/S	N/S	N/S	1-1/4	1-5/16	1-9/16	1-9/16
Black	108-92-2	108-91-2	108-90-2	108-90-2	108-27-2	N/S	N/S	N/S	1-13/32	1-13/64	1-3/8	2
Black	34-202	108-91-2	108-90-2	108-90-2	108-27-2	N/S	N/S	N/S	1-13/32	1-13/64	1-3/8	2
Plain	108-83-2	108-91-2	108-83-2	108-89-2	N/R	N/S	N/A	N/S	1-1/4	1-5/16	1-9/16	1-9/16
Black	108-92-2	108-91-2	108-90-2	108-90-2	108-27-2	N/S	N/S	N/S	1-13/32	1-13/64	1-3/8	2
Purple	108-56-2	108-55-2	108-90-2	108-90-2	108-13-2	N/S	N/S	N/S	1-1/4	1-5/16	1-9/16	1-9/16
Brown	108-56-2	108-55-2	108-90-2	108-90-2	108-13-2	N/S	N/S	N/S	1-1/4	1-5/16	1-9/16	1-9/16
Pink	108-56-2	108-55-2	108-90-2	108-90-2	108-13-2	N/S	N/S	N/S	1-1/4	1-5/16	1-9/16	1-9/16
Pink	108-56-2	108-55-2	108-90-2	108-90-2	108-13-2	N/S	N/S	N/S	1-1/4	1-5/16	1-9/16	1-9/16
Black	108-92-2	108-35-2	108-90-2	108-90-2	108-27-2	N/S	N/S	N/S	1-13/32	1-13/64	1-3/8	2
0.035	108-105	108-106	108-105	108-106	N/R	134-108	134-112	N/S	1-11/16	1-11/16	2	2
0.035	108-105	108-106	108-105	108-106	N/R	134-108	134-112	N/S	1-11/16	1-11/16	2	2
0.035	108-105	108-106	108-105	108-106	N/R	134-108	134-112	N/S	1-11/16	1-11/16	2	2
Pink	N/A	N/A	N/A	N/A	108-13-2	N/S	N/S	N/S	1-1/4	1-5/16	1-9/16	1-9/16
Brown	N/A	N/A	N/A	N/A	108-13-2	N/S	N/S	N/S	1-1/4	1-5/16	1-9/16	1-9/16
Brown	N/A	N/A	N/A	N/A	108-13-2	N/S	N/S	N/S	1-1/4	1-5/16	1-9/16	1-9/16
Brown	N/A	N/A	N/A	N/A	108-13-2	N/S	N/S	N/S	1-1/4	1-5/16	1-9/16	1-9/16
Brown	N/A	N/A	N/A	N/A	108-13-2	N/S	N/S	N/S	1-1/4	1-5/16	1-9/16	1-9/16
N/R	N/A	N/A	N/R	N/R	N/R	N/S	N/R	N/S	1-3/16	N/R	1-1/2	N/R
N/R	N/A	N/A	N/A	N/R	N/R	N/R	N/S	N/R	N/S	1-3/16	N/R	1-1/2
0.035	N/A	N/A	N/A	N/A	N/R	134-108	134-112	N/R	1-11/16	1-11/16	2	2
0.035	N/A	N/A	N/A	N/A	N/R	134-108	134-112	N/R	1-11/16	1-11/16	2	2
Plain	N/A	N/A	N/A	N/A	108-27-2	N/S	N/S	N/S	1-3/32	1-3/32	1-1/2	1-1/2
N/R	N/A	N/A	N/R	N/R	N/R	N/S	N/R	N/S	1-9/16	N/R	1-3/4	N/R
Plain	108-83-2	108-89-2	108-90-2	108-90-2	108-27-2	N/S	N/S	N/S	1-3/16	1-1/4	1-1/2	1-1/2
Plain	108-83-2	108-89-2	108-90-2	108-90-2	108-27-2	N/S	N/S	N/S	1-3/16	1-1/4	1-1/2	1-1/2
Pink	108-83-2	108-89-2	108-83-2	108-89-2	N/R	134-103	134-102	N/A	1-9/16	1-9/16	1-3/4	1-3/4
0.031	N/A	N/A	N/A	N/A	N/R	N/S	N/S	N/S	1-9/16	1-9/16	1-3/4	1-3/4
Black	108-83-2	108-89-2	108-90-2	108-90-2	N/R	N/S	N/S	N/S	1-1/4	1-5/16	1-9/16	1-9/16
Black	108-83-2	108-89-2	108-90-2	108-90-2	N/R	N/S	N/S	N/S	1-1/4	1-5/16	1-9/16	1-9/16
Black	108-83-2	108-89-2	108-90-2	108-90-2	N/R	N/S	N/S	N/S	1-1/4	1-5/16	1-9/16	1-9/16
Black	108-83-2	108-89-2	108-90-2	108-90-2	N/R	N/S	N/S	N/S	1-1/4	1-5/16	1-9/16	1-9/16
Black	108-83-2	108-89-2	108-90-2	108-90-2	N/R	134-101	134-105	N/S	1-1/4	1-5/16	1-9/16	1-9/16
Black	108-83-2	108-89-2	108-90-2	108-90-2	N/R	134-101	134-105	N/A	1-1/4	1-5/16	1-9/16	1-9/16
Black	108-83-2	108-89-2	108-90-2	108-90-2	N/R	134-101S	134-105S	N/A	1-1/4	1-5/16	1-9/16	1-9/16
Black	108-83-2	108-89-2	108-90-2	108-90-2	N/R	134-101S	134-105S	N/A	1-1/4	1-5/16	1-9/16	1-9/16
Black	108-83-2	108-89-2	108-90-2	108-90-2	N/R	134-101S	134-105S	N/A	1-1/4	1-5/16	1-9/16	1-9/16
Black	108-83-2	108-89-2	108-90-2	108-90-2	N/R	134-101S	134-105S	N/A	1-1/4	1-5/16	1-9/16	1-9/16
Black	108-83-2	108-89-2	108-90-2	108-90-2	N/R	134-281S	134-282S	112-113	1-1/4	1-5/16	1-9/16	1-9/16
Black	108-83-2	108-89-2	108-90-2	108-90-2	N/R	N/S	N/S	N/S	1-1/4	1-5/16	1-9/16	1-9/16
Black	108-92-2	108-91-2	108-90-2	108-90-2	108-27-2	N/S	N/A	N/S	1-13/32	1-13/64	1-3/8	2
Red	N/A	N/A	N/A	N/A	108-27-2	N/S	N/S	N/S	1-1/4	1-5/16	1-9/16	1-9/16
N/A	N/A	N/A	N/A	N/A	108-27-2	N/S	N/S	N/S	1-1/4	1-5/16	1-9/16	1-9/16
0.031	108-105	108-106	108-105	108-106	N/R	134-108	134-112	N/A	1-3/8	1-3/8	1-3/4	1-3/4
0.031	108-105	108-106	108-105	108-106	N/R	134-108	134-112	112-122	1-3/8	1-3/8	1-3/4	1-3/4
Brown	108-105	108-106	108-105	108-106	N/R	134-108	34R11442	N/A	1-3/8	1-3/8	1-3/4	1-3/4

See pages 190 & 191 for numerical listing specific footnotes.

HOW TO CHOOSE A CARB
STREET CARBURETORS
SUPERCHARGER CARBURETORS
RACE CARBURETORS
MARINE CARBURETORS
CARB SERVICE PARTS & ACCESSORIES
FUEL INJECTION
THROTTLE BODIES
FUEL PUMPS
INTAKE MANIFOLDS
CYLINDER HEADS
SYSTEMAX
ENGINE DRESS-UP
MERCHANDISING
TECHNICAL INFORMATION
INDEX

HOW TO CHOOSE A CARB	Carburetor Part No.	Carb. Model No.	CFM	Renew Kit	Trick Kit	Needle & Seal	Primary Main Jet	Secondary Main Jet or Plate	Primary Metering Block	Secondary Metering Block	Power Valve	Pump Nozzle Size, Primary
STREET CARBURETORS	R80497-1	4150	950	37-1539	37-933	6-518-2	122-78	122-78	N/A	N/A	125-165 (both)	0.031
STREET CARBURETORS	R80498	4150	950	37-1539	37-933	6-519-2	122-144	122-144	N/A	N/A	125-155 (both)	0.055
STREET CARBURETORS	R80498-1	4150	950	37-1539	37-933	6-519-2	122-144	122-144	N/A	N/A	125-155 (both)	0.055
STREET CARBURETORS	R80507	4150	390	37-1539	37-933	6-504	122-65	122-65	N/A	N/A	125-35 (22)	0.025
STREET CARBURETORS	R80507-1	4150	390	37-1539	37-933	6-504	122-65	122-65	N/A	N/A	125-35 (22)	0.025
SUPERCARGER CARBURETORS	R80507-2	4150	390	37-1539	37-933	6-504	122-65	122-65	N/A	N/A	125-35 (22)	0.025
SUPERCARGER CARBURETORS	R80507-3	4150	390	37-1539	37-933	6-504	122-65	122-65	N/A	N/A	125-35 (22)	0.025
SUPERCARGER CARBURETORS	R80508	4160	750	37-754	37-933	6-504	122-72	134-21	134-131	134-21	125-65	0.025
SUPERCARGER CARBURETORS	R80508-1	4160	750	37-754	37-933	6-504	122-72	134-21	134-131S	134-21	125-65	0.025
SUPERCARGER CARBURETORS	R80508-2	4160	750	37-754	37-933	6-504	122-72	134-21	134-131S	134-21	125-65	0.031
RACE CARBURETORS	R80508-3	4160	750	37-754	37-933	6-504	122-70	134-21	N/A	134-21	125-65	0.031
RACE CARBURETORS	R80508-4	4160	750	37-754	37-933	6-504	122-70	134-21	N/A	134-21	125-65	0.031
RACE CARBURETORS	R80508-5	4160	750	37-754	37-933	6-504	122-70	134-21	N/A	134-21	125-65	0.031
RACE CARBURETORS	R80508-6	4160	750	37-754	37-933	6-504	122-70	134-21	N/A	134-21	125-65	0.031
RACE CARBURETORS	R80508-7	4160	750	37-754	37-933	6-504	122-70	134-21	N/A	134-21	125-65	0.031
MARINE CARBURETORS	R80509	4150	830	37-1539	37-933	6-504	122-86	122-86	N/A	N/A	125-65 (15)	0.028
MARINE CARBURETORS	R80509-1	4150	830	37-1539	37-933	6-504	122-86	122-86	N/A	N/A	125-65 (15)	0.028
MARINE CARBURETORS	R80509-2	4150	830	37-1539	37-933	6-504	122-86	122-86	N/A	N/A	125-65 (15)	0.028
CARB SERVICE PARTS & ACCESSORIES	R80511	4150	830	37-1539	37-933	6-518-2	122-84	122-84	N/A	N/A	125-65 (15)	0.028
CARB SERVICE PARTS & ACCESSORIES	R80511-1	4150	830	37-1539	37-933	6-518-2	122-84	122-84	N/A	N/A	125-65 (15)	0.028
FUEL INJECTION	R80511-2	4150	830	37-1539	37-933	6-518-2	122-84	122-84	N/A	N/A	125-65 (15)	0.028
FUEL INJECTION	R80512	4150	1000	37-1539	37-933	6-518-2	122-84	122-84	N/A	N/A	125-65 (15)	0.031
FUEL INJECTION	R80513	4150	1000	37-1539	37-933	6-518-2	122-84	122-84	N/A	N/A	125-65 (15)	0.031
FUEL INJECTION	R80513-1	4150	1000	37-1539	37-933	6-518-2	122-84	122-84	N/A	N/A	125-65 (15)	0.031
FUEL INJECTION	R80514	4150	1000	37-1539	37-933	6-518-2	122-84	122-88	N/A	N/A	125-65 (15)	0.031
THROTTLE BODIES	R80514-1	4150	1000	37-1539	37-933	6-518-2	122-84	122-88	N/A	N/A	125-65 (15)	0.031
THROTTLE BODIES	R80519	4150	1000	37-1539	37-933	6-518-2	122-84	122-88	N/A	N/A	125-65 (15)	0.031
THROTTLE BODIES	R80528	4150	750	37-1539	37-933	6-504	122-72	122-84	134-261	134-261	125-65	0.031
THROTTLE BODIES	R80528-1	4150	750	37-1539	37-933	6-504	122-73	122-73	134-261	134-261	125-65 (15)	0.031
THROTTLE BODIES	R80528-2	4150	750	37-1539	37-933	6-504	122-73	122-73	134-67	134-67	125-65 (15)	0.031
FUEL PUMPS	R80529	4150	750	37-1539	37-933	6-504	122-72	122-84	134-261	134-261	125-65	0.031
FUEL PUMPS	R80529-1	4150	750	37-1539	37-933	6-504	122-72	122-84	134-261	134-261	N/R	0.031
FUEL PUMPS	R80531	4150	850	37-1539	37-933	6-504	122-78	122-82	N/A	N/A	125-45 (22)	0.04
INTAKE MANIFOLDS	R80532	4500	1250	37-1539	37-933	6-518-2	122-97	122-97	N/A	N/A	N/R	0.035
INTAKE MANIFOLDS	R80532-1	4500	1250	37-1539	37-933	6-518-2	122-97	122-97	N/A	N/A	N/R	0.035
INTAKE MANIFOLDS	R80533	4500	1250	37-1539	37-933	6-518-2	122-97	122-97	N/A	N/A	N/R	0.035
INTAKE MANIFOLDS	R80533-1	4500	1250	37-1539	37-933	6-518-2	122-97	122-97	N/A	N/A	N/R	0.035
CYLINDER HEADS	R80535	4150	750	37-1539	37-933	6-519-2	122-132	122-132	N/A	N/A	125-55	0.045
CYLINDER HEADS	R80535-1	4150	750	37-1539	37-933	6-519-2	122-144	122-144	N/A	N/A	125-55	0.045
CYLINDER HEADS	R80535-2	4150	750	37-1539	37-933	6-519-2	122-144	122-144	N/A	N/A	125-55	0.045
CYLINDER HEADS	R80535-3	4150	750	37-1539	37-933	6-519-2	122-144	122-144	N/A	N/A	125-55	0.045
SYSTEMAX	R80537	4150	750	3-485	N/A	6-504	122-73	122-81	N/S	N/A	125-65	0.028
SYSTEMAX	R80540	4150	600	37-1539	37-933	6-518-2	122-70	122-70	N/A	N/A	125-65	0.028
SYSTEMAX	R80540-1	4150	600	37-1539	37-933	6-518-2	122-70	122-70	N/A	N/A	125-65	0.028
SYSTEMAX	R80540-2	4150	600	37-1539	37-933	6-518-2	122-70	122-70	N/A	N/A	125-65	0.028
ENGINE DRESS-UP	R80541	4150	650	37-1539	37-933	6-518-2	122-70	122-70	N/A	N/A	125-65	0.028
ENGINE DRESS-UP	R80541-1	4150	650	37-1539	37-933	6-518-2	122-70	122-70	N/A	N/A	125-65	0.028
ENGINE DRESS-UP	R80541-2	4150	650	37-1539	37-933	6-518-2	122-70	122-70	134-68	134-68	125-65	0.028
ENGINE DRESS-UP	R80542	4150	650	37-1539	37-933	6-519-2	122-90	122-90	N/A	N/A	125-65	0.055
ENGINE DRESS-UP	R80542-1	4150	650	37-1539	37-933	6-519-2	122-90	122-90	N/A	N/A	125-65	0.055
MERCHANDISING	R80551	4160	600	703-1	N/A	6-511	122-63	N/A	N/A	N/A	125-25	0.037
MERCHANDISING	R80551-1	4160	600	703-1	N/A	6-511	122-63	N/A	N/A	N/A	125-25	0.037
MERCHANDISING	R80552	4175	650	703-34	N/A	6-511	122-61	N/A	N/A	N/A	125-50	0.04
MERCHANDISING	R80555	4175	650	37-1537	37-933	6-510	122-62	N/A	N/A	N/A	125-65	0.04
MERCHANDISING	R80555-1	4175	650	37-1537	37-933	6-510	122-62	N/A	N/A	N/A	125-65	0.04
TECHNICAL INFORMATION	R80556	4500	1150	37-1539	37-933	6-518-2	122-90	122-90	N/A	N/A	125-55	0.035
TECHNICAL INFORMATION	R80556-1	4500	1150	37-1539	37-933	6-518-2	122-90	122-90	N/A	N/A	125-55	0.035

See pages 190 & 191 for numerical listing specific footnotes.

Secondary Nozzle Size or Spring Color	Primary Bowl Gasket*	Primary Metering Block Gasket	Secondary Bowl Gasket	Secondary Metering Block Gasket	Secondary Metering Plate Gasket	Primary Fuel Bowl	Secondary Fuel Bowl	Throttle Body & Shaft Assembly	Venturii Diameter Primary	Venturii Diameter Secondary	Throttle Bore Diameter Primary	Throttle Bore Diameter Secondary
Brown	108-105	108-106	108-105	108-106	N/R	134-108	N/A	N/A	1-3/8	1-3/8	1-3/4	1-3/4
0.055	108-105	108-106	108-105	108-106	N/R	N/A	N/A	N/A	1-3/8	1-3/8	1-3/4	1-3/4
0.055	108-105	108-106	108-105	108-106	N/R	N/A	N/A	N/A	1-3/8	1-3/8	1-3/4	1-3/4
0.025	108-105	108-106	108-105	108-106	N/R	134-103	134-104	N/A	1-1/16	1-1/16	1-7/16	1-7/16
0.025	108-105	108-106	108-105	108-106	N/R	134-103	134-104	N/A	1-1/16	1-1/16	1-7/16	1-7/16
0.025	108-105	108-106	108-105	108-106	N/R	134-103	134-104	N/A	1-1/16	1-1/16	1-7/16	1-7/16
Plain	108-83-2	108-89-2	108-90-2	108-90-2	108-27-2	134-103	134-102	N/S	1-3/8	1-7/16	1-11/16	1-11/16
Plain	108-83-2	108-89-2	108-90-2	108-90-2	108-27-2	134-103S	134-102S	N/A	1-3/8	1-7/16	1-11/16	1-11/16
Plain	108-83-2	108-89-2	108-90-2	108-90-2	108-27-2	134-103S	134-102S	N/A	1-3/8	1-7/16	1-11/16	1-11/16
	108-83-2	108-89-2	108-90-2	108-90-2	108-27-2	134-103S	134-102S	N/A	1-3/8	1-7/16	1-11/16	1-11/16
	108-83-2	108-89-2	108-90-2	108-90-2	108-27-2	134-103S	134-102S	N/A	1-3/8	1-7/16	1-11/16	1-11/16
	108-83-2	108-89-2	108-90-2	108-90-2	108-27-2	134-103S	134-102S	N/A	1-3/8	1-7/16	1-11/16	1-11/16
	108-83-2	108-89-2	108-90-2	108-90-2	108-27-2	134-103S	134-102S	N/A	1-3/8	1-7/16	1-11/16	1-11/16
	108-83-2	108-89-2	108-90-2	108-90-2	108-27-2	134-103S	134-102S	112-117	1-3/8	1-7/16	1-11/16	1-11/16
0.029	108-83-2	108-89-2	108-83-2	108-89-2	N/R	134-103	134-104	N/S	1-9/16	1-9/16	1-11/16	1-11/16
0.029	108-83-2	108-89-2	108-83-2	108-89-2	N/R	134-103	134-104	N/S	1-9/16	1-9/16	1-11/16	1-11/16
0.029	108-83-2	108-89-2	108-83-2	108-89-2	N/R	134-103	134-104	N/S	1-9/16	1-9/16	1-11/16	1-11/16
0.029	108-83-2	108-89-2	108-83-2	108-89-2	N/R	134-108	134-112	N/S	1-9/16	1-9/16	1-11/16	1-11/16
0.029	108-83-2	108-89-2	108-83-2	108-89-2	N/R	134-108	134-112	N/S	1-9/16	1-9/16	1-11/16	1-11/16
0.029	108-83-2	108-89-2	108-83-2	108-89-2	N/R	134-108	134-112	N/S	1-9/16	1-9/16	1-11/16	1-11/16
Brown	108-83-2	108-89-2	108-83-2	108-89-2	N/R	134-108	N/A	N/A	1-9/16	1-9/16	1-3/4	1-3/4
0.036	108-83-2	108-89-2	108-83-2	108-89-2	N/R	134-108	134-112	N/A	1-9/16	1-9/16	1-3/4	1-3/4
0.036	108-83-2	108-89-2	108-83-2	108-89-2	N/R	134-108	134-112	N/A	1-9/16	1-9/16	1-3/4	1-3/4
0.036	108-83-2	108-89-2	108-83-2	108-89-2	N/R	134-108	134-112	N/A	1-9/16	1-9/16	1-3/4	1-3/4
0.036	108-83-2	108-89-2	108-83-2	108-89-2	N/R	134-108	134-112	N/A	1-9/16	1-9/16	1-3/4	1-3/4
Brown	108-83-2	108-89-2	108-83-2	108-89-2	N/R	134-108	N/A	N/A	1-9/16	1-9/16	1-3/4	1-3/4
0.031	108-83-2	108-89-2	108-83-2	108-89-2	N/R	134-108	134-112	N/A	1-3/8	1-3/8	1-11/16	1-11/16
0.031	108-83-2	108-89-2	108-83-2	108-89-2	N/R	134-108	134-112	N/A	1-3/8	1-3/8	1-11/16	1-11/16
0.031	108-83-2	108-89-2	108-83-2	108-89-2	N/R	134-108	134-112	112-120	1-3/8	1-3/8	1-11/16	1-11/16
Brown	108-83-2	108-89-2	108-83-2	108-89-2	N/R	134-108	N/A	112-107	1-3/8	1-3/8	1-11/16	1-11/16
Brown	108-83-2	108-89-2	108-83-2	108-89-2	N/R	134-108	N/A	112-107	1-3/8	1-3/8	1-11/16	1-11/16
Pink	108-83-2	108-89-2	108-90-2	108-89-2	N/R	N/A	N/A	N/A	1-3/8	1-3/8	1-11/16	1-11/16
0.037	108-83-2	108-121	108-120	108-121	N/R	134-108	134-112	N/S	1.880"	1.880"	2-1/8	2-1/8
0.037	108-120	108-121	108-120	108-121	N/R	134-108	134-112	N/S	1.880"	1.880"	2-1/8	2-1/8
0.037	108-120	108-121	108-120	108-121	N/R	134-108	134-112	N/S	1.880"	1.880"	2-1/8	2-1/8
0.037	108-120	108-121	108-120	108-121	N/R	134-108	134-112	N/S	1.880"	1.880"	2-1/8	2-1/8
0.045	108-83-2	108-89-2	108-83-2	108-89-2	N/R	134-108	134-112	N/A	1-3/8	1-3/8	1-11/16	1-11/16
0.045	108-83-2	108-89-2	108-83-2	108-89-2	N/R	134-108	134-112	N/A	1-3/8	1-3/8	1-11/16	1-11/16
0.045	108-83-2	108-89-2	108-83-2	108-89-2	N/R	134-108	134-112	N/A	1-3/8	1-3/8	1-11/16	1-11/16
0.045	108-83-2	108-89-2	108-83-2	108-89-2	N/R	134-108	134-112	N/A	1-3/8	1-3/8	1-11/16	1-11/16
0.031	N/A	N/A	N/A	N/A	N/R	134-108	134-112	N/S	1-3/8	1-3/8	1-11/16	1-11/16
0.029	108-83-2	108-89-2	108-83-2	108-89-2	N/R	134-108	134-112	N/A	1-1/4	1-1/4	1-9/16	1-9/16
0.029	108-83-2	108-89-2	108-83-2	108-89-2	N/R	134-108	134-112	N/A	1-1/4	1-1/4	1-9/16	1-9/16
0.029	108-83-2	108-89-2	108-83-2	108-89-2	N/R	134-108	134-112	N/A	1-1/4	1-1/4	1-9/16	1-9/16
0.029	108-83-2	108-89-2	108-83-2	108-89-2	N/R	134-108	134-112	N/A	1-1/4	1-1/4	1-11/16	1-11/16
0.029	108-83-2	108-89-2	108-83-2	108-89-2	N/R	134-108	134-112	N/A	1-1/4	1-1/4	1-11/16	1-11/16
0.029	108-83-2	108-89-2	108-83-2	108-89-2	N/R	134-108	134-112	112-121	1-1/4	1-1/4	1-11/16	1-11/16
0.055	108-83-2	108-89-2	108-83-2	108-89-2	N/R	N/A	N/A	N/A	1-1/4	1-1/4	1-11/16	1-11/16
0.055	108-83-2	108-89-2	108-83-2	108-89-2	N/R	N/A	N/A	N/A	1-1/4	1-1/4	1-11/16	1-11/16
Red	N/A	N/A	N/A	N/A	N/A	N/A	N/A	N/A	1-3/8	1-7/16	1-9/16	1-9/16
Red	N/A	N/A	N/A	N/A	N/A	N/A	N/A	N/A	1-3/8	1-7/16	1-9/16	1-9/16
Red	N/A	N/A	N/A	N/A	N/A	N/A	N/A	N/A	1-13/64	1-13/32	1-3/8	2
Yellow	108-92-2	108-91-2	108-90-2	108-90-2	108-27-2	N/A	N/A	N/A	1-13/64	1-13/32	1-3/8	2
Yellow	108-92-2	108-91-2	108-90-2	108-90-2	108-27-2	N/A	N/A	N/A	1-13/64	1-13/32	1-3/8	2
0.035	108-120	108-121	108-120	108-121	N/R	N/A	N/A	N/S	2	2	1.83	1.83
0.035	108-120	108-121	108-120	108-121	N/R	N/A	N/A	N/S	2	2	1.83	1.83

See pages 190 & 191 for numerical listing specific footnotes.

HOW TO CHOOSE A CARB
STREET CARBURETORS
SUPERCHARGER CARBURETORS
RACE CARBURETORS
MARINE CARBURETORS
CARB SERVICE PARTS & ACCESSORIES
FUEL INJECTION
THROTTLE BODIES
FUEL PUMPS
INTAKE MANIFOLDS
CYLINDER HEADS
SYSTEMAX
ENGINE DRESS-UP
MERCHANDISING
TECHNICAL INFORMATION
INDEX

HOW TO CHOOSE A CARB	Carburetor Part No.	Carb. Model No.	CFM	Renew Kit	Trick Kit	Needle & Seal	Primary Main Jet	Secondary Main Jet or Plate	Primary Metering Block	Secondary Metering Block	Power Valve	Pump Nozzle Size, Primary
STREET CARBURETORS	R80559	4150	600	N/A	N/A	6-504	122-67	122-74	N/A	N/A	125-65	0.028
STREET CARBURETORS	R80570	4160	570	37-934	N/A	6-506	122-54	122-65	N/S	N/S	125-85	0.031
STREET CARBURETORS	R80572	4150	700	N/A	37-933	6-504	122-72	122-82	N/A	N/A	125-105	0.028
STREET CARBURETORS	R80573	4150	750	N/A	37-933	6-504	122-74	122-84	N/A	N/A	125-105	0.028
STREET CARBURETORS	R80574	4150	800	N/A	N/A	6-504	122-74	122-82	N/A	N/A	125-105	0.031
SUPERCHARGER CARBURETORS	R80575	4150	600	37-1544	37-933	6-518-2	122-73	122-73	N/A	N/A	125-105	0.028
SUPERCHARGER CARBURETORS	R80575-1	4150	600	37-1544	37-933	6-518-2	122-73	122-73	N/A	N/A	125-105	0.028
SUPERCHARGER CARBURETORS	R80576	4150	750	N/A	37-933	6-504	122-76	122-87	N/A	N/A	125-105	0.031
SUPERCHARGER CARBURETORS	R80576-1	4150	750	37-1544	37-933	6-504	122-76	122-87	N/A	N/A	125-105	0.031
SUPERCHARGER CARBURETORS	R80577	4150	850	37-1544	37-933	6-518-2	122-80	122-86	N/A	N/A	125-105	0.031
RACE CARBURETORS	R80577-1	4150	850	37-1544	37-933	6-504	122-80	122-86	N/A	N/A	125-105	0.031
RACE CARBURETORS	R80578	4500	1150	N/A	37-933	6-518-2	122-99	122-99	N/A	N/A	N/R	0.035
MARINE CARBURETORS	R80583-1	2300	500	37-1543	N/A	6-520	122-73	N/A	N/S	N/A	125-35	0.028
MARINE CARBURETORS	R80670	4160	670	37-935	37-933	6-506	122-65	122-68	N/S	N/S	125-65	0.031
MARINE CARBURETORS	R80670-1	4160	670	37-935	37-933	6-504	122-65	122-68	N/S	N/S	125-65	0.031
MARINE CARBURETORS	R80670-2	4160	670	37-935	37-933	6-504	122-65	122-68	134-57	134-58	125-65	0.031
CARB SERVICE PARTS & ACCESSORIES	R80672	4500	1050	37-1539	37-933	6-518-2	122-88	122-88	N/A	N/A	125-55 (both)	0.035
CARB SERVICE PARTS & ACCESSORIES	R80673	4500	1150	37-1539	37-933	6-518-2	122-90	122-90	N/A	N/A	125-55 (both)	0.035
CARB SERVICE PARTS & ACCESSORIES	R80674	4150	650	37-1539	37-933	6-518-2	122-70	122-70	N/A	N/A	125-65 (both)	0.028
CARB SERVICE PARTS & ACCESSORIES	R80675	4150	750	37-1539	37-933	6-504	122-73	122-73	N/A	N/A	125-65 (both)	0.031
FUEL INJECTION	R80676	4150	950	37-1539	37-933	6-518-2	122-78	122-78	N/A	N/A	125-65 (both)	0.031
FUEL INJECTION	R80681	4150	670	37-936	N/A	6-513	122-68	122-89	N/A	N/A	125-25	0.028
FUEL INJECTION	R80770	4160	770	37-935	N/A	6-506	122-72	122-75	N/S	N/S	125-65	0.025
FUEL INJECTION	R80770-1	4160	770	37-935	37-933	6-504	122-72	122-75	134-59	134-60	125-65	0.025
FUEL INJECTION	R80776	4150	600	37-485	37-933	6-504	122-66	122-73	34R8519AS	N/A	125-65	0.028
THROTTLE BODIES	R80777	4150	650	37-485	37-933	6-504	122-67	122-73	134-150	N/A	125-65	0.028
THROTTLE BODIES	R80778	4150	700	37-485	37-933	6-504	122-69	122-78	N/A	N/A	125-65	0.028
THROTTLE BODIES	R80779	4150	750	37-485	37-933	6-504	122-70	122-80	N/A	N/A	125-65	0.028
THROTTLE BODIES	R80780	4150	800	37-485	37-933	6-504	122-71	122-85	N/A	N/A	125-65	0.031
THROTTLE BODIES	R80781	4150	850	37-485	37-933	6-504	122-80	122-78	N/A	N/A	125-65 (15)	0.031
FUEL PUMPS	R80783	4150	650	N/A	N/A	6-504	122-67	122-73	34-150	N/A	125-65	0.028
FUEL PUMPS	R80783-1	4150	650	N/A	N/A	6-504	122-67	122-73	34-150	N/A	125-65	0.028
FUEL PUMPS	R80787-1	2300	350	N/A	N/A	6-520	122-77	N/A	134-276	N/A	125-45	0.021
INTAKE MANIFOLDS	R80870	4160	870	37-934	N/A	6-506	122-78	122-82	N/S	N/S	125-45	0.042
INTAKE MANIFOLDS	R80870-1	4160	870	37-934	37-933	6-504	122-78	122-82	N/S	N/S	125-45	0.042
CYLINDER HEADS	R81570	4150	570	37-934	37-933	6-506	122-54	122-65	N/A	N/A	125-85	0.031
CYLINDER HEADS	R81670	4150	670	37-935	37-933	6-506	122-65	122-68	N/A	N/A	125-65	0.031
CYLINDER HEADS	R81770	4150	770	37-935	37-933	6-506	122-72	122-75	N/A	N/A	125-65	0.025
CYLINDER HEADS	R81870	4150	870	37-934	37-933	6-504	122-78	122-82	N/A	N/A	125-45 (22)	0.04
CYLINDER HEADS	R81850	4160	600	37-119	37-933	6-506	122-66	134-9	134-128	134-9	125-65	0.025
SYSTEMAX	R82010	2010	350	37-1541	N/A	6-504	122-58	N/A	N/R	N/R	125-65	0.035
SYSTEMAX	R82011	2010	500	37-1541	N/A	6-504	122-80	N/A	N/R	N/R	125-65	0.035
SYSTEMAX	R82012	2010	560	37-1541	N/A	6-504	122-80	N/A	N/R	N/R	125-65	0.035
SYSTEMAX	R82750	4150	750	37-1539	37-933	6-504	122-75	122-76	N/A	N/A	125-45	0.031
SYSTEMAX	R82751	4150	750	37-1539	37-933	6-504	122-75	122-80	N/A	N/A	125-45	0.031
ENGINE DRESS-UP	R83310	4160	750	37-754	37-933	6-504	122-72	134-21	134-131	134-21	125-65	0.025
ENGINE DRESS-UP	R83310-1	4160	750	37-754	37-933	6-504	122-72	134-21	134-131	134-21	125-65	0.025
ENGINE DRESS-UP	R83311	4160	750	37-754	37-933	6-504	122-72	134-21	134-131	134-21	125-65	0.025
ENGINE DRESS-UP	R83312	4160	750	37-754	37-933	6-504	122-72	134-21	134-131	134-21	125-65	0.025
MERCHANDISING	R84010	4010	600	37-1541	N/A	6-504	122-67	122-75	N/R	N/R	125-65	0.026
MERCHANDISING	R84010-1	4010	600	37-1541	N/A	6-504	122-67	122-75	N/R	N/R	125-65	0.035
MERCHANDISING	R84010-2	4010	600	37-1541	N/A	6-504	122-67	122-75	N/R	N/R	125-65	0.035
MERCHANDISING	R84010-3	4010	600	37-1541	N/A	6-504	122-63	122-75	N/R	N/R	125-65	0.035
MERCHANDISING	R84011	4010	750	37-1541	N/A	6-504	122-75	122-75	N/R	N/R	125-65 (15)	0.026
MERCHANDISING	R84011-1	4010	750	37-1541	N/A	6-504	122-75	122-75	N/R	N/R	125-65 (15)	0.035
MERCHANDISING	R84011-2	4010	750	37-1541	N/A	6-504	122-75	122-75	N/R	N/R	125-65	0.035
MERCHANDISING	R84011-3	4010	750	37-1541	N/A	6-504	122-73	122-75	N/R	N/R	125-65	0.031

See pages 190 & 191 for numerical listing specific footnotes.

Secondary Nozzle Size or Spring Color	Primary Bowl Gasket ¹	Primary Metering Block Gasket	Secondary Bowl Gasket	Secondary Metering Block Gasket	Secondary Metering Plate Gasket	Primary Fuel Bowl	Secondary Fuel Bowl	Throttle Body & Shaft Assembly	Venturii Diameter Primary	Venturii Diameter Secondary	Throttle Bore Diameter Primary	Throttle Bore Diameter Secondary
0.032	N/A	N/A	N/A	N/A	N/R	34R11341-1	34R11335	12R11335A	1-1/4	1-5/16	1-9/16	1-9/16
Plain	108-83-2	108-89-2	108-83-2	108-89-2	N/R	N/S	N/S	N/S	1-3/32	1-3/32	1-1/2	1-1/2
0.031	108-83-2	108-89-2	108-83-2	108-89-2	N/R	134-103S	134-104S	N/A	1-5/16	1-3/8	1-11/16	1-11/16
0.031	108-83-2	108-89-2	108-83-2	108-89-2	N/R	134-103S	134-104S	N/A	1-3/8	1-3/8	1-11/16	1-11/16
0.031	108-83-2	108-89-2	108-83-2	108-89-2	N/R	134-103S	134-104S	N/A	1-3/8	1-7/16	1-11/16	1-11/16
0.029	108-83-2	108-89-2	108-83-2	108-89-2	N/R	N/A	N/A	N/A	1-1/4	1-1/4	1-9/16	1-9/16
0.029	108-83-2	108-89-2	108-83-2	108-89-2	N/R	134-102S	134-104S	N/A	1-1/4	1-1/4	1-9/16	1-9/16
0.031	108-83-2	108-89-2	108-83-2	108-89-2	N/R	134-108	134-112	N/A	1-3/8	1-3/8	1-11/16	1-11/16
0.031	108-83-2	108-89-2	108-83-2	108-89-2	N/R	134-108	134-112	N/A	1-3/8	1-3/8	1-11/16	1-11/16
0.031	108-83-2	108-89-2	108-83-2	108-89-2	N/R	134-108	134-112	N/A	1 3/8	1 3/8	1 3/4	1 3/4
0.031	108-83-2	108-89-2	108-83-2	108-89-2	N/R	134-108	134-112	N/A	1 3/8	1 3/8	1 3/4	1 3/4
0.035	108-120	108-121	108-120	108-121	N/R	134-108	134-112	N/R	1-13/16	1-13/16	2	2
N/A	108-83-2	108-89-2	N/A	N/A	N/A	N/S	N/A	N/S	1-3/8	N/R	1-11/16	N/R
Plain	108-83-2	108-89-2	108-83-2	108-89-2	N/R	N/S	N/S	N/S	1-1/4	1-5/16	1-9/16	1-9/16
Plain	108-83-2	108-89-2	108-83-2	108-89-2	N/R	N/S	N/S	N/S	1-1/4	1-5/16	1-9/16	1-9/16
Plain	108-83-2	108-89-2	108-83-2	108-89-2	N/R	N/S	N/S	112-114	1-1/4	1-5/16	1-9/16	1-9/16
0.035	108-120	108-121	108-120	108-121	N/R	N/A	N/A	N/S	1-11/16	1-11/16	2	2
0.035	108-120	108-121	108-120	108-121	N/R	N/A	N/A	N/S	2	2	1.83	1.83
0.029	108-83-2	108-89-2	108-83-2	108-89-2	N/R	N/A	N/A	N/A	1-1/4	1-1/4	1-11/16	1-11/16
0.031	108-83-2	108-89-2	108-83-2	108-89-2	N/R	N/A	N/A	N/A	1-3/8	1-3/8	1-11/16	1-11/16
0.031	108-83-2	108-89-2	108-83-2	108-89-2	N/R	N/A	N/A	N/A	1-3/8	1-3/8	1-3/4	1-3/4
Black	108-83-2	108-89-2	108-83-2	108-89-2	N/R	N/A	N/A	N/A N/A	1-1/4	1-5/16	1-9/16	1-9/16
Plain	108-83-2	108-89-2	108-83-2	108-89-2	N/R	N/S	N/S	N/S	1-3/8	1-7/16	1-11/16	1-11/16
0.031	108-83-2	108-89-2	108-83-2	108-89-2	N/R	N/S	N/S	112-115	1-3/8	1-7/16	1-11/16	1-11/16
0.031	108-83-2	108-89-2	108-83-2	108-89-2	N/R	134-103	134-104	N/A	1-1/4	1-5/16	1-9/16	1-9/16
0.028	108-83-2	108-89-2	108-83-2	108-89-2	N/R	134-103	134-104	112-117	1-1/4	1-5/16	1-11/16	1-11/16
0.031	108-83-2	108-89-2	108-83-2	108-89-2	N/R	134-103	134-104	N/A	1-5/16	1-3/8	1-11/16	1-11/16
0.031	108-83-2	108-89-2	108-83-2	108-89-2	N/R	134-103	134-104	N/A	1-3/8	1-3/8	1-11/16	1-11/16
0.031	108-83-2	108-89-2	108-83-2	108-89-2	N/R	134-103	134-104	N/A	1-3/8	1-7/16	1-11/16	1-11/16
0.031	108-83-2	108-89-2	108-83-2	108-89-2	N/R	134-103	134-104	N/A	1-9/16	1-9/16	1-3/4	1-3/4
Yellow	108-83-2	108-89-2	108-83-2	108-89-2	N/R	134-103S	134-104S		1-1/4	1-5/16	1-11/16	1-11/16
Yellow	108-83-2	108-89-2	108-83-2	108-89-2	N/R	134-103S	134-104S		1-1/4	1-5/16	1-11/16	1-11/16
N/R	108-105	108-106	N/A	N/A	N/A	N/S	N/A	N/S	1-3/16	N/R	1-1/2	N/R
Plain	108-83-2	108-89-2	108-83-2	108-89-2	N/R	N/S	N/S	N/S	1-3/8	1-3/8	1-11/16	1-11/16
0.031	108-83-2	108-89-2	108-83-2	108-89-2	N/R	N/S	N/S	N/S	1-3/8	1-3/8	1-11/16	1-11/16
Plain	108-83-2	108-89-2	108-83-2	108-89-2	N/R	N/A	N/A	N/A	1-1/4	1-5/16	1-9/16	1-9/16
Plain	108-83-2	108-89-2	108-83-2	108-89-2	N/R	N/A	N/A	N/A	1-3/8	1-7/16	1-11/16	1-11/16
Plain	108-83-2	108-89-2	108-83-2	108-89-2	N/R	N/A	N/A	N/A	1-3/8	1-3/8	1-11/16	1-11/16
Plain	108-83-2	108-89-2	108-90-2	108-90-2	N/R	134-101	134-105	112-20	1-1/4	1-5/16	1-9/16	1-9/16
Plain	108-83-2	108-89-2	108-83-2	108-89-2	N/R	N/A	N/A	N/A	1-3/32	1-3/32	1-1/2	1-1/2
N/R	N/S	N/S	N/S	N/S	N/R	N/R	N/R	N/R	1-3/16	N/R	1-11/16	N/R
N/R	N/S	N/S	N/S	N/S	N/R	N/R	N/R	N/R	1-9/16	N/R	1-11/16	N/R
N/R	N/S	N/S	N/S	N/S	N/R	N/R	N/R	N/R	1-9/16	N/R	1-3/4	N/R
Plain	108-83-2	108-89-2	108-83-2	108-89-2	N/R	N/A	N/A	N/A	1-3/8	1-3/8	1-11/16	1-11/16
0.028	108-83-2	108-89-2	108-83-2	108-89-2	N/R	N/A	N/A	N/A	1-3/8	1-3/8	1-11/16	1-11/16
Plain	108-83-2	108-89-2	108-90-2	108-90-2	108-27-2	134-103	134-102	N/S	1-3/8	1-7/16	1-11/16	1-11/16
Plain	108-83-2	108-89-2	108-90-2	108-90-2	108-27-2	134-103	134-102	N/S	1-3/8	1-7/16	1-11/16	1-11/16
Plain	108-83-2	108-89-2	108-83-2	108-89-2	N/R	134-103	134-102	N/S	1-3/8	1-7/16	1-11/16	1-11/16
Plain	108-83-2	108-89-2	108-83-2	108-89-2	N/R	134-103	134-102	N/S	1-3/8	1-7/16	1-11/16	1-11/16
Purple	(3)	(3)	(3)	(3)	(3)	N/R	N/R	N/R	1-1/4	1-1/4	1-11/16	1-11/16
Purple	(3)	(3)	(3)	(3)	(3)	N/R	N/R	N/R	1-1/4	1-1/4	1-11/16	1-11/16
Purple	(3)	(3)	(3)	(3)	(3)	N/R	N/R	N/R	1-1/4	1-1/4	1-11/16	1-11/16
Purple	(3)	(3)	(3)	(3)	(3)	N/R	N/R	N/R	1-1/2	1-1/2	1-11/16	1-11/16
Purple	(3)	(3)	(3)	(3)	(3)	N/R	N/R	N/R	1-1/2	1-1/2	1-11/16	1-11/16
Purple	(3)	(3)	(3)	(3)	(3)	N/R	N/R	N/R	1-1/2	1-1/2	1-11/16	1-11/16
Purple	(3)	(3)	(3)	(3)	(3)	N/R	N/R	N/R	1-1/2	1-1/2	1-11/16	1-11/16
Purple	(3)	(3)	(3)	(3)	(3)	N/R	N/R	N/R	1-1/2	1-1/2	1-11/16	1-11/16

See pages 190 & 191 for numerical listing specific footnotes.

HOW TO CHOOSE A CARB
STREET CARBURETORS
SUPERCHARGER CARBURETORS
RACE CARBURETORS
MARINE CARBURETORS
CARB SERVICE PARTS & ACCESSORIES
FUEL INJECTION
THROTTLE BODIES
FUEL PUMPS
INTAKE MANIFOLDS
CYLINDER HEADS
SYSTEMAX
ENGINE DRESS-UP
MERCHANDISING
TECHNICAL INFORMATION
INDEX

190 TECHNICAL INFORMATION - Carburetor Numerical Listing

HOW TO CHOOSE A CARB	Carburetor Part No.	Carb. Model No.	CFM	Renew Kit	Trick Kit	Needle & Seal	Primary Main Jet	Secondary Main Jet or Plate	Primary Metering Block	Secondary Metering Block	Power Valve	Pump Nozzle Size, Primary
STREET CARBURETORS	R84012	4010	600	37-1541	N/A	6-504	122-67	122-77	N/R	N/R	125-65	0.026
	R84012-1	4010	600	37-1541	N/A	6-504	122-67	122-77	N/R	N/R	125-65	0.035
	R84012-2	4010	600	37-1541	N/A	6-504	122-67	122-77	N/R	N/R	125-65	0.035
	R84012-3	4010	600	37-1541	N/A	6-504	122-67	122-77	N/R	N/R	125-65	0.031
SUPERCHARGER CARBURETORS	R84013	4010	750	37-1541	N/A	6-504	122-79	122-79	N/R	N/R	125-65 (15)	0.026
	R84013-1	4010	750	37-1541	N/A	6-504	122-79	122-79	N/R	N/R	125-65 (15)	0.035
	R84013-2	4010	750	37-1541	N/A	6-504	122-79	122-79	N/R	N/R	125-65 (15)	0.035
	R84013-3	4010	750	37-1541	N/A	6-504	122-75	122-79	N/R	N/R	125-65	0.031
RACE CARBURETORS	R84014	4011	650	37-1541	N/A	6-504	122-60	122-66	N/R	N/R	125-65 (15)	0.026
	R84014-1	4011	650	37-1541	N/A	6-504	122-60	122-66	N/R	N/R	125-65 (15)	0.026
	R84014-2	4011	650	37-1541	N/A	6-504	122-60	122-64	N/R	N/R	125-65 (15)	0.026
	R84014-3	4011	650	37-1541	N/A	6-504	122-60	122-64	N/R	N/R	125-65 (15)	0.026
MARINE CARBURETORS	R84015	4011	800	37-1541	N/A	6-504	122-64	122-90	N/R	N/R	125-65 (15)	0.026
	R84015-1	4011	800	37-1541	N/A	6-504	122-64	122-90	N/R	N/R	125-65 (15)	0.026
	R84015-2	4011	800	37-1541	N/A	6-504	122-60	122-90	N/R	N/R	125-65 (15)	0.026
	R84015-3	4011	800	37-1541	N/A	6-504	122-60	122-90	N/R	N/R	125-65 (15)	0.026
CARB SERVICE PARTS & ACCESSORIES	R84016	4011	650	37-1541	N/A	6-504	122-64	122-64	N/R	N/R	125-65 (15)	0.026
	R84016-1	4011	650	37-1541	N/A	6-504	122-64	122-64	N/R	N/R	125-65 (15)	0.026
	R84016-2	4011	650	37-1541	N/A	6-504	122-60	122-64	N/R	N/R	125-65 (15)	0.026
	R84016-3	4011	650	37-1541	N/A	6-504	122-60	122-64	N/R	N/R	125-65 (15)	0.026
FUEL INJECTION	R84017	4011	800	37-1541	N/A	6-504	122-64	122-90	N/R	N/R	125-65 (15)	0.026
	R84017-1	4011	800	37-1541	N/A	6-504	122-64	122-90	N/R	N/R	125-65 (15)	0.026
	R84017-2	4011	800	37-1541	N/A	6-504	122-60	122-90	N/R	N/R	125-65 (15)	0.026
	R84017-3	4011	800	37-1541	N/A	6-504	122-60	122-90	N/R	N/R	125-65 (15)	0.026
	R84020	4010	600	37-1541	N/A	6-504	122-67	122-75	N/R	N/R	125-65	0.026
THROTTLE BODIES	R84020-1	4010	600	37-1541	N/A	6-504	122-67	122-75	N/R	N/R	125-65	0.035
	R84020-2	4010	600	37-1541	N/A	6-504	122-67	122-75	N/R	N/R	125-65	0.035
	R84020-3	4010	600	37-1541	N/A	6-504	122-63	122-75	N/R	N/R	125-65	0.035
	R84021	4011	650	37-1541	N/A	6-504	122-60	122-64	N/R	N/R	125-65 (15)	0.026
	R84021-1	4011	650	37-1541	N/A	6-504	122-60	122-64	N/R	N/R	125-65 (15)	0.026
	R84021-2	4011	650	37-1541	N/A	6-504	122-60	122-64	N/R	N/R	125-65 (15)	0.026
	R84021-3	4011	650	37-1541	N/A	6-504	122-60	122-64	N/R	N/R	125-65 (15)	0.026
FUEL PUMPS	R84035	4010	600	37-1541	N/A	6-504	122-67	122-75	N/R	N/R	125-65	0.035
	R84035-1	4010	600	37-1541	N/A	6-504	122-67	122-75	N/R	N/R	125-65	0.035
	R84035-2	4010	600	37-1541	N/A	6-504	122-63	122-75	N/R	N/R	125-65	0.035
INTAKE MANIFOLDS	R84047	4010	750	37-1541	N/A	6-504	122-75	122-75	N/R	N/R	125-65 (15)	0.035
	R84047-1	4010	750	37-1541	N/A	6-504	122-73	122-75	N/R	N/R	125-65 (15)	0.031
CYLINDER HEADS	R84412	2300	500	37-474	37-933	6-504	122-73	N/R	134-137	N/R	125-50	0.028
	R84776	4150	600	37-485	37-933	6-504	122-66	122-73	N/A	N/A	125-65	0.028
	R84777	4150	650	37-485	37-933	6-504	122-67	122-73	134-150	N/A	125-65	0.028
	R84778	4150	700	37-485	37-933	6-504	122-69	122-78	N/S	N/S	125-65	0.028
	R84779	4150	750	37-485	37-933	6-504	122-70	122-73	N/A	N/S	125-65	0.028
	R84780	4150	800	37-485	37-933	6-504	122-71	122-85	N/A	N/S	125-65	0.031
	R84781	4150	850	37-485	37-933	6-504	122-80	122-78	N/S	N/S	125-65	0.031
	R87448	2300	350	37-1536	37-933	6-504	122-61	N/A	134-203	N/R	125-85	0.031
SYSTEMAX	R89834	4160	600	37-720	37-933	6-506	122-68	134-39	N/S	134-39	125-65	0.031
ENGINE DRESS-UP	R90470	4150	470	37-936	N/A	6-513	122-57	122-57	N/A	N/A	125-25	0.035
	R90670	4150	670	N/A	N/A	6-513 (2)	122-68	122-89	N/S	N/S	125-65	0.028
	R90670-1	4150	670	37-936	N/A	6-513	122-68	122-89	N/S	N/S	125-65	0.028
	R90670-2	4150	670	37-936	N/A	6-513	122-68	122-89	N/S	N/S	125-65	0.028
MERCHANDISING	R90770	4150	770	37-936	N/A	6-513	125-74	122-99	N/A	N/A	125-25	0.035

(1) 122-80 Choke Side; 122-90 Throttle Side

(2) Model 2010 Airhorn Gasket is Available Under Part Number 108-75

(3) Model 4010 Airhorn Gasket is Available Under Part Number 108-63

(4) Model 4011 Airhorn Gasket is Available Under Part Number 108-64

(5) Main Body Gasket

(12) 125-85 Secondary

(13) 125-105 Primary

(14) 125-85 Primary

(15) 125-65 Secondary

(16) 6-511 Primary

Secondary Nozzle Size or Spring Color	Primary Bowl Gasket*	Primary Metering Block Gasket	Secondary Bowl Gasket	Secondary Metering Block Gasket	Secondary Metering Plate Gasket	Primary Fuel Bowl	Secondary Fuel Bowl	Throttle Body & Shaft Assembly	Venturii Diameter Primary	Venturii Diameter Secondary	Throttle Bore Diameter Primary	Throttle Bore Diameter Secondary
0.026	(3)	(3)	(3)	(3)	(3)	N/R	N/R	N/R	1-1/4	1-1/4	1-11/16	1-11/16
0.026	(3)	(3)	(3)	(3)	(3)	N/R	N/R	N/R	1-1/4	1-1/4	1-11/16	1-11/16
0.026	(3)	(3)	(3)	(3)	(3)	N/R	N/R	N/R	1-1/4	1-1/4	1-11/16	1-11/16
0.026	(3)	(3)	(3)	(3)	(3)	N/R	N/R	N/R	1-1/4	1-1/4	1-11/16	1-11/16
0.026	(3)	(3)	(3)	(3)	(3)	N/R	N/R	N/R	1-1/2	1-1/2	1-11/16	1-11/16
0.026	(3)	(3)	(3)	(3)	(3)	N/R	N/R	N/R	1-1/2	1-1/2	1-11/16	1-11/16
0.026	(3)	(3)	(3)	(3)	(3)	N/R	N/R	N/R	1-1/2	1-1/2	1-11/16	1-11/16
Plain	(4)	(4)	(4)	(4)	(4)	N/R	N/R	N/R	1-5/32	1-3/8	1-3/8	2
Plain	(4)	(4)	(4)	(4)	(4)	N/R	N/R	N/R	1-5/32	1-3/8	1-3/8	2
Plain	(4)	(4)	(4)	(4)	(4)	N/R	N/R	N/R	1-5/32	1-3/8	1-3/8	2
Plain	(4)	(4)	(4)	(4)	(4)	N/R	N/R	N/R	1-5/32	1-3/8	1-3/8	2
Yellow	(4)	(4)	(4)	(4)	(4)	N/R	N/R	N/R	1-5/32	1-23/32	1-3/8	2
Yellow	(4)	(4)	(4)	(4)	(4)	N/R	N/R	N/R	1-5/32	1-23/32	1-3/8	2
Yellow	(4)	(4)	(4)	(4)	(4)	N/R	N/R	N/R	1-5/32	1-23/32	1-3/8	2
Plain	(4)	(4)	(4)	(4)	(4)	N/R	N/R	N/R	1-5/32	1-23/32	1-3/8	2
0.026	(4)	(4)	(4)	(4)	(4)	N/R	N/R	N/R	1-5/32	1-3/8	1-3/8	2
0.026	(4)	(4)	(4)	(4)	(4)	N/R	N/R	N/R	1-5/32	1-3/8	1-3/8	2
0.026	(4)	(4)	(4)	(4)	(4)	N/R	N/R	N/R	1-5/32	1-3/8	1-3/8	2
0.026	(4)	(4)	(4)	(4)	(4)	N/R	N/R	N/R	1-5/32	1-3/8	1-3/8	2
0.026	(4)	(4)	(4)	(4)	(4)	N/R	N/R	N/R	1-5/32	1-23/32	1-3/8	2
0.026	(4)	(4)	(4)	(4)	(4)	N/R	N/R	N/R	1-5/32	1-23/32	1-3/8	2
0.026	(4)	(4)	(4)	(4)	(4)	N/R	N/R	N/R	1-5/32	1-23/32	1-3/8	2
0.026	(4)	(4)	(4)	(4)	(4)	N/R	N/R	N/R	1-5/32	1-23/32	1-3/8	2
Purple	(3)	(3)	(3)	(3)	(3)	N/R	N/R	N/R	1-1/4	1-1/4	1-11/16	1-11/16
Purple	(3)	(3)	(3)	(3)	(3)	N/R	N/R	N/R	1-1/4	1-1/4	1-11/16	1-11/16
Purple	(3)	(3)	(3)	(3)	(3)	N/R	N/R	N/R	1-1/4	1-1/4	1-11/16	1-11/16
Plain	(4)	(4)	(4)	(4)	(4)	N/R	N/R	N/R	1-5/32	1-3/8	1-3/8	2
Plain	(4)	(4)	(4)	(4)	(4)	N/R	N/R	N/R	1-5/32	1-3/8	1-3/8	2
Plain	(4)	(4)	(4)	(4)	(4)	N/R	N/R	N/R	1-5/32	1-3/8	1-3/8	2
Purple	(3)	(3)	(3)	(3)	(3)	N/R	N/R	N/R	1-1/4	1-1/4	1-11/16	1-11/16
Purple	(3)	(3)	(3)	(3)	(3)	N/R	N/R	N/R	1-1/4	1-1/4	1-11/16	1-11/16
Purple	(3)	(3)	(3)	(3)	(3)	N/R	N/R	N/R	1-1/4	1-1/4	1-11/16	1-11/16
Black	(3)	(3)	(3)	(3)	(3)	N/R	N/R	N/R	1-1/2	1-1/2	1-11/16	1-11/16
Purple	(3)	(3)	(3)	(3)	(3)	N/R	N/R	N/R	1-1/2	1-1/2	1-11/16	1-11/16
N/R	108-83-2	108-89-2	N/R	N/R	N/R	134-103	N/R	112-2	1-3/8	N/R	1-11/16	N/R
0.032	108-83-2	108-89-2	108-83-2	108-89-2	N/R	134-103	134-104	N/A	1-1/4	1-5/16	1-9/16	1-9/16
0.028	108-83-2	108-89-2	108-83-2	108-89-2	N/R	134-103	134-104	112-17	1-1/4	1-5/16	1-11/16	1-11/16
0.031	108-83-2	108-89-2	108-83-2	108-89-2	N/R	134-103	134-104	N/A	1-5/16	1-3/8	1-11/16	1-11/16
0.031	108-83-2	108-89-2	108-83-2	108-89-2	N/R	134-103	134-104	N/S	1-3/8	1-3/8	1-11/16	1-11/16
0.031	108-83-2	108-89-2	108-83-2	108-89-2	N/R	134-103	134-104	N/A	1-3/8	1-7/16	1-11/16	1-11/16
0.031	108-83-2	108-89-2	108-83-2	108-89-2	N/R	134-103	134-104	N/S	1-9/16	1-9/16	1-3/4	1-3/4
N/R	108-83-2	108-89-2	N/R	N/R	N/R	134-103	N/R	N/A	1-3/16	N/R	1-1/2	N/R
Black	108-83-2	108-91-2	108-90-2	108-90-2	108-27-2	N/A	134-105	N/S	1-1/4	1-5/16	1-9/16	1-9/16
Black	108-83-2	108-89-2	108-83-2	108-89-2	N/R	N/A	N/A	N/A	1-3/32	1-3/32	1-1/2	1-1/2
Black	108-83-2	108-89-2	108-83-2	108-89-2	N/R	N/S	N/S	N/S	1-1/4	1-5/16	1-9/16	1-9/16
Black	108-83-2	108-89-2	108-83-2	108-89-2	N/R	N/S	N/S	N/S	1-1/4	1-5/16	1-9/16	1-9/16
Black	108-83-2	108-89-2	108-83-2	108-89-2	N/R	N/S	N/S	N/S	1-1/4	1-5/16	1-9/16	1-9/16
Black	108-83-2	108-89-2	108-83-2	108-89-2	N/R	N/A	N/A	N/A	1-3/8	1-7/16	1-11/16	1-11/16

(17) 6-510 Secondary

(21) 125-65 Primary

(22) 125-35 Secondary

(24) 25R-475A-13 Early versions must use 108-29 to seal pump passage.

(29) 122-75 Diaphragm side; 122-80 Throttle Lever side

(30) 125-25 Secondary

N/A Not Available

N/S Not Serviced

N/R Not Required

*NOTE: Gasket Part Numbers now have a (-2) suffix to denote 2 gaskets per package.

For example: 108-38-2.

HOW TO CHOOSE A CARB
STREET CARBURETORS
SUPERCHARGER CARBURETORS
RACE CARBURETORS
MARINE CARBURETORS
CARB SERVICE PARTS & ACCESSORIES
FUEL INJECTION
THROTTLE BODIES
FUEL PUMPS
INTAKE MANIFOLDS
CYLINDER HEADS
SYSTEMAX
ENGINE DRESS-UP
MERCHANDISING
TECHNICAL INFORMATION
INDEX

Inside Your Holley Carburetor

The carburetor is quite simply a fuel metering device that operates under the logical and straightforward laws of physics. It has evolved over the years from a very simple and basic design to the complex and intricate models that are available today. A carburetor's functions can be easily analyzed and understood but at the same time it can be frustratingly difficult to troubleshoot problems associated with it. Many times a carburetor is looked at as the prime culprit or the main cause for a myriad of other engine-related difficulties that might exist. Therefore, it's best to check and verify the condition of the complete engine system before proceeding with any carburetor work.

There should be no vacuum leaks, the carburetor floats and the ignition timing should be properly set and the carburetor and engine should both be in sound mechanical condition. There's an old saying that "You can't beat a dead horse". Well, the same can be said about carburetors. Tuning

the carburetor won't cure bad valves, leaky head gaskets, worn piston rings or cracked and leaking vacuum lines and, no matter how much time and effort you devote toward it, the results will be the same.

Fuel Inlet System

The fuel inlet system consists of a fuel bowl, fuel inlet fitting, fuel inlet needle and seat, and a float assembly. A fuel inlet screen or filter is usually installed in the fuel inlet fitting. However, if there is no filter or screen in the fuel inlet fitting, an in-line filter must be installed to prevent dirt or other contaminants from entering the carburetor.

Holley performance carburetors are equipped with a fuel bowl that is designed either for a center pivot or a side pivot float. An externally adjustable needle and seat assembly is used so that the float level can be easily adjusted without the need to disassemble the carburetor.

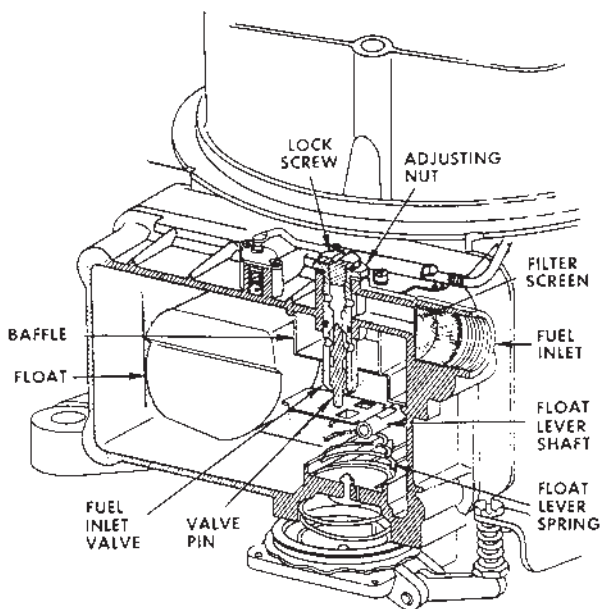

**Fuel Inlet System. Side Pivot/Hung Float.
Externally Adjustable Fuel Inlet Valve.**

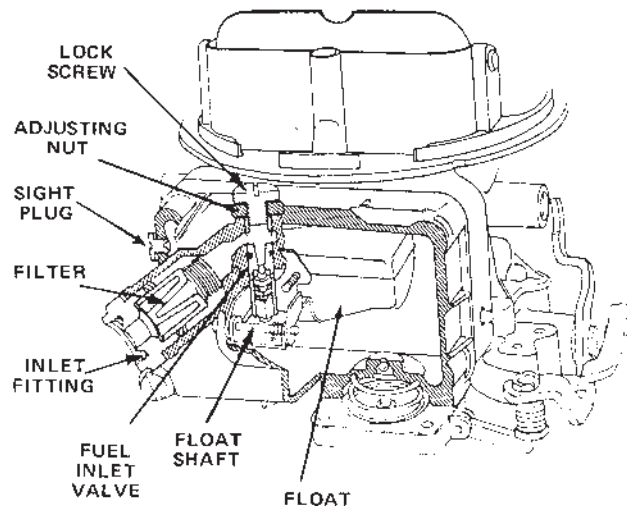

**Fuel Inlet System. Center Pivot/Hung Float.
Externally Adjustable Fuel Inlet Valve.**

Idle System

The idle system supplies the air/fuel mixture to operate the engine at idle and low speeds. Fuel enters the main well through the main metering jet that is screwed into the metering block. Some of this fuel is then bled off to an idle well where it is mixed with air from the idle air bleed hole. The idle well leads directly to the idle discharge port and the idle transfer system where this air/fuel mixture is discharged.

Most Holley Street Performance, O.E. Muscle Car, Competition and Pro-Series HP carburetors utilize idle mixture screws, located on the sides of the primary metering block. These control the volume of the pre-mixed air/fuel coming through the idle well. Turning the screws clockwise will "lean" the idle system. Conversely, turning the screws counterclockwise will "richen" the idle system.

The initial adjustment is made by turning the mixture screws in a clockwise direction until they lightly bottom. Back them both off 1-1/2 turns. Connect a vacuum gauge to a carburetor vacuum port that will have access to full manifold vacuum at idle. Start the engine and allow it to warm up. Once the engine has warmed up and the idle stabilized, the choke should be disengaged. Adjust the idle mixture screws to obtain the highest vacuum reading. Each screw should be turned an equal amount so that the system is balanced.

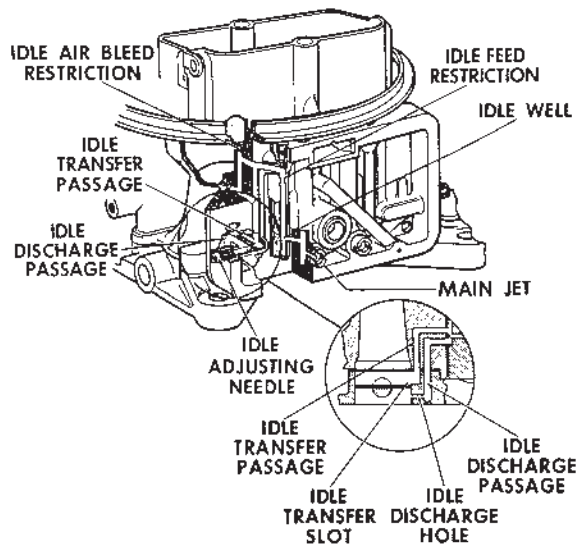
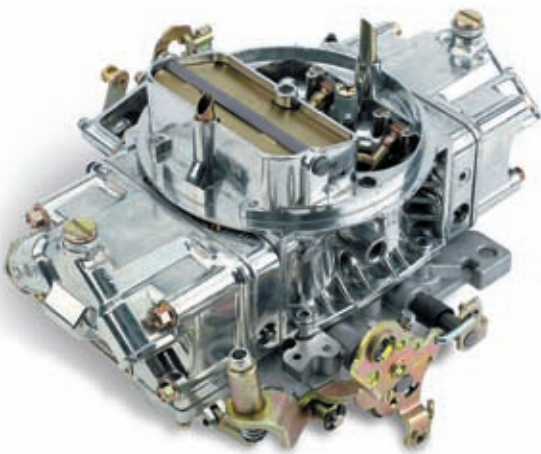

Idle System.
Model 2300 — Primary Side 4V.

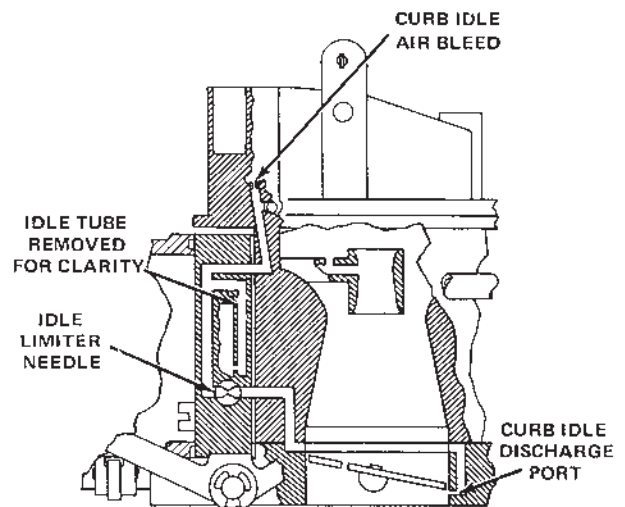

Curb Idle System.
Primary Idle Transfer System.

Main Metering System

The main metering system is designed to supply the leanest fuel mixture for cruising in the 35 MPH and over range. Operation is simple. Fuel from the main metering jet enters the main well and is mixed with air from the high speed air bleed. Engine vacuum pulls this air/fuel mixture and discharges it through the booster venturi and into the manifold through the throttle bores.

On a street vehicle optimum jetting can be determined by driving at various steady speeds and taking vacuum and spark plug readings. Manifold vacuum will increase the closer you get to ideal jetting; it will fall off once you get past this point. The ideal color for the spark plug porcelain is light brown or tan. A color lighter than this indicates that the carburetor is jetted lean; a darker color indicates that the carburetor is jetted rich.

Holley jets are number-stamped on their side for identification purposes. A higher relative number indicates a larger jet size. Changing to a larger or smaller jet will either richen or make leaner the carburetor's fuel curve from part throttle to full throttle, respectively.

NOTE: Jump two sizes when changing the carburetor jetting. There is approximately a 4-1/2% flow difference from one jet size to the next and one size won't make that much of a difference. If you must go up or down 8-10 jet sizes then you have a problem either with the fuel delivery system or the carburetor is wrong for the application.

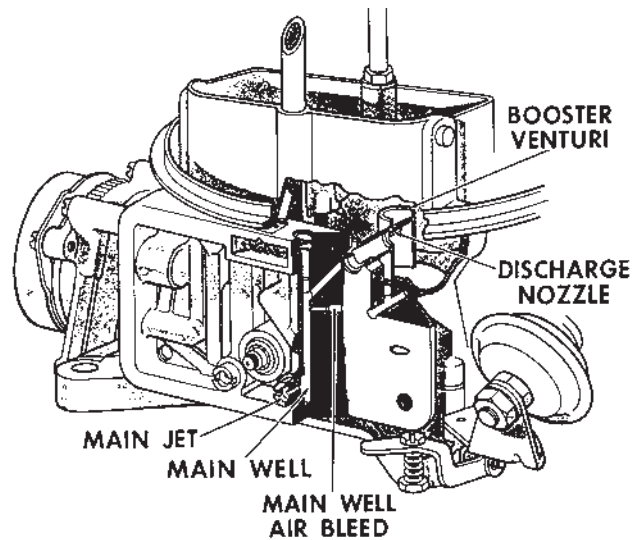

Main Metering System.

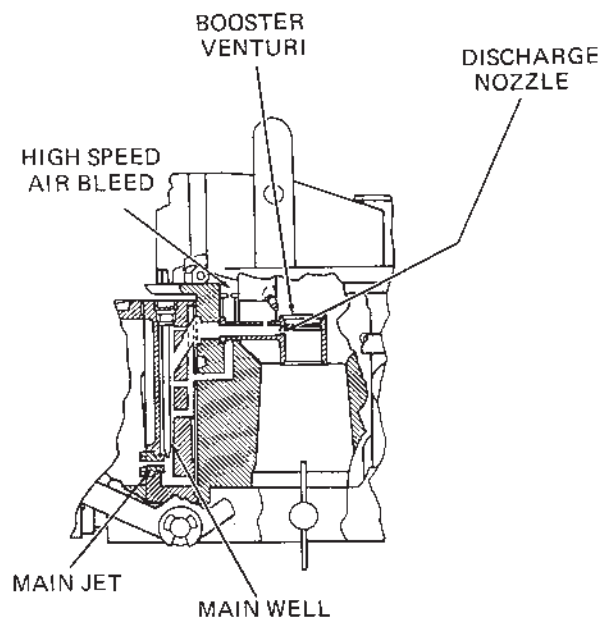

Side View Main Metering System.
Showing Idle Tube in Main Well.

Accelerator Pump System

The accelerator pump system consists of three main components: the pump diaphragm, the pump cam and the pump nozzle. This is the carburetor system that is most responsible for having good, crisp, off-idle throttle response. Its purpose is to inject a certain amount of fuel down the throttle bores when the throttle is opened. By accomplishing this purpose it acts to smooth the transition between the idle and main circuits so that no stumble, hesitation or sluggishness will be evident during this transition phase.

The first adjustment to check is the clearance between the pump operating lever and the pump diaphragm cover's arm, at wide open throttle. This clearance should be around .015". The purpose for this clearance is to assure that the pump diaphragm is never stretched to its maximum limit at wide open throttle. This will cause premature pump failure. Once this clearance has been set take a good look at the pump linkage and work the throttle. Make sure that the accelerator pump arm is being activated the moment that the throttle begins to move. This will assure that pump response will be instantaneous to the movement of the throttle. These adjustments can be made by turning the accelerator pump adjusting screw that is located on the accelerator pump arm together with the pump override spring and lock nut.

The amount of fuel that can be delivered by one accelerator pump stroke is determined by the pump's capacity and the profile of the pump cam. The period of time that it will take for this pre-determined amount of fuel to be delivered is affected by the pump nozzle size.

A larger pump nozzle will allow this fuel to be delivered much sooner than a smaller pump nozzle. If you need more pump shot sooner, then a larger pump nozzle size is required. During acceleration tests, if you notice that the car first hesitates and then picks up, it's a sure bet that the pump nozzle size should be increased. A backfire (lean condition) on acceleration also calls for a step up in pump nozzle size. Conversely, if off-idle acceleration does not feel crisp or clean, then the pump nozzle size may already be too large. In this case a smaller size is required.

Holley accelerator pump nozzles are stamped with a number which indicates the drilled pump hole size. For example, a pump nozzle stamped "35" is drilled .035". Pump nozzle sizes are available from .025" to .052". Please note that whenever a .040" or larger accelerator pump nozzle is installed the "hollow" pump nozzle screw should also be used. This screw will allow more fuel to flow to the pump nozzle, assuring that the pump nozzle itself will be the limiting restriction in the accelerator pump fuel supply system.

Accelerator Pump System.

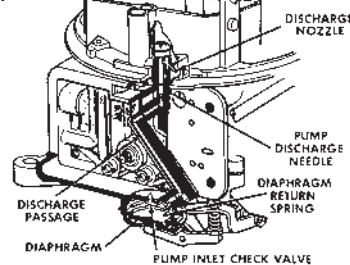

Figure 8—Accelerator Pump System with Plastic Inlet Check Valve.

NOTE: When changing the pump nozzle it's best to jump three sizes. For example if there's currently an off-line hesitation with #28 (.028") pump nozzle, try a #31 (.031") pump nozzle. If you must use a #37 (.037") or larger pump nozzle, then also use a 50cc pump.

The same applies to the accelerator pump cams. Once a pump nozzle size selection has been made the accelerator pump system can be further tailored with the pump cam. Holley offers an assortment of different pump cams, each with uniquely different lift and duration profiles, that are available under Holley P/N 20-12. Switching cams will directly affect the movement of the accelerator pump lever and, subsequently, the amount of fuel available at the pump nozzle. Lay out the pump cams side by side and note the profile differences. This little exercise may help to better explain the differences between the cams and their effect on pump action.

Installing a pump cam is straightforward. It's a simple matter of loosening one screw, placing the new pump cam next to the throttle lever and tightening it up. There are two and sometimes three holes in each pump cam, numbered 1, 2 and 3. Placing the screw in position #1 activates the accelerator pump a little early, allowing full use of the pump's capacity. Generally, vehicles which normally run at lower idle speeds (600 or 700 RPM) find this position more useful because they can have a good pump shot available coming right off this relatively low idle. Positions #2 and #3 delay the pump action, relatively speaking. These two cam positions are good for engines that idle around 1000 RPM and above. Repositioning the cam in this way makes allowance for the extra throttle rotation required to maintain the relatively higher idle setting. Pump arm adjustment and clearance should be checked and verified each and every time the pump cam and/or pump cam position is changed.

Lastly, a 50cc accelerator pump conversion kit is available under Holley P/N 20-11 when maximum pump capacity is desired.

Power Enrichment System

The power enrichment system supplies additional fuel to the main system during heavy load or full power situations. Holley carburetors utilize a vacuum operated power enrichment system and a selection of power valves is available to "time" this system's operation to your specific needs. Each Holley power valve is stamped with a number to indicate the vacuum opening point. For example, the number "65" indicates that the power valve will open when the engine vacuum drops to 6.5" or below. An accurate vacuum gauge, such as Holley P/N 26-501, should be used when determining the correct power valve to use. A competition or race engine which has a long duration high overlap camshaft will have low manifold vacuum at idle speeds. If the vehicle has a manual transmission, take the vacuum reading with the engine thoroughly warmed up and at idle. If the vehicle is equipped with an automatic transmission, take the vacuum reading with the engine thoroughly warmed up and idling in gear. In either case, the power valve selected should be 1/2 the intake manifold vacuum reading taken. EXAMPLE: 13" Hg vacuum reading divided by 2 = 6.5 power valve. If your reading divided by 2 lands on an even number you should select the next lowest power valve. EXAMPLE: 8" Hg vacuum reading divided by 2 = 4 power valve. Since there is no #4 power valve you should a 3.5.

Most of the popular Holley "Street Legal" and "Street Performance" carburetors incorporate a power valve blow-out protection system. A special check valve is located in the throttle body expressly for this purpose. This check valve is designed to be normally open but will quickly seat to close off the internal vacuum passage when a backfire occurs. Once closed, the check valve interrupts the pressure wave caused by the backfire, thus protecting the power valve.

If you have a carburetor older than 1992 (or you have experienced an extreme backfire) and expect a blown power valve, use this simple test. TEST: At idle turn your idle mixture screws (found on the side of the metering block) all the way in. If your engine dies the power valve is not blown.

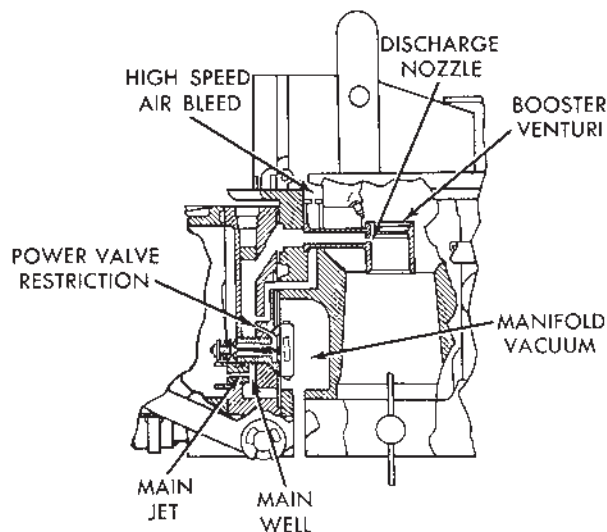

Power Enrichment System.

THE TRUTH ABOUT POWER VALVES USED WITH HOLLEY CARBURETORS

There still seems to be a lot of misconception about Holley carburetors blowing power valves. Nothing could be further from the truth. Holley performance carburetors built since 1992 have utilized a power valve check system that effectively eliminated this infrequent problem. Consisting of a spring, brass seat and check ball, the check ball system is 100% effective protecting the power valve diaphragm from damage due to engine backfire.

The power valve check ball is designed to be normally open but quickly seals to close off the internal vacuum passage when a backfire occurs. Once closed, the check valve interrupts the pressure wave generated by the backfire, thus protecting the power valve diaphragm. There is no way that the power valve's diaphragm can rupture due to an engine backfire!

Choke System

The choke system is designed to supply a rich fuel mixture to the engine for cold starts and cold drive-away conditions.

Holley carburetors with chokes will come equipped with either a manual, electric or hot air choke. All Holley square flange carburetors originally equipped with either a manual or hot air choke can be converted to automatic electric choke operation with the proper kit. Conversely, those equipped with either an electric or hot air choke can be converted to manual choke operation with the proper kit.

Secondary System

The secondary system of a Holley four barrel carburetor can be either vacuum or mechanically operated.

The opening rate of a mechanical secondary system is pre-determined by the linkage which is usually designed to allow the secondary throttle plates to begin opening once the primary throttle plates have rotated open about 40 degrees. Special Holley kits are also available which will allow the conversion to 1:1 linkage (primary and secondary throttle plates opening simultaneously) for special racing applications.

The opening rate of a vacuum secondary system is controlled by the diaphragm spring located in the vacuum secondary diaphragm housing. A "lighter" spring will allow the secondary throttle plates to open more quickly. A spring assortment kit, Holley P/N 20-13, is available to help you "tailor" the secondary opening rate to your application. A "quick change" kit, Holley P/N 20-59, is also available for fast and easy access to the spring. It consists of a two-piece secondary diaphragm housing cover which, after it's installed, can easily cut in half the time required to change the secondary spring.

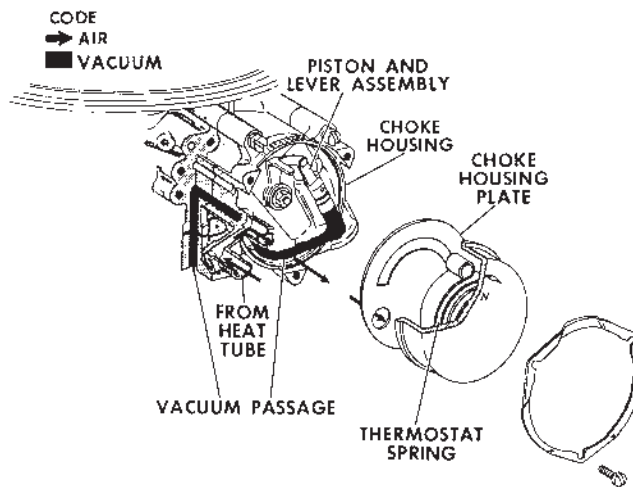

Integral Automatic Choke.

DO NOT put a screw in the linkage of a vacuum secondary carburetor to mechanically "force" open the secondary throttle plates. Normally there is an accelerator pump on the secondary side of a mechanical secondary carburetor. The purpose of the secondary pump is to inject additional fuel to "cover" the transition time up to the point when the secondary main system starts to flow. Without this secondary pump shot the engine will go to an instant lean condition. Therefore, forcing the secondaries to open prematurely will hinder performance and may cause an engine backfire. The screw could also create a bind and cause the throttle to stick open.

Vacuum Operated Secondary System.

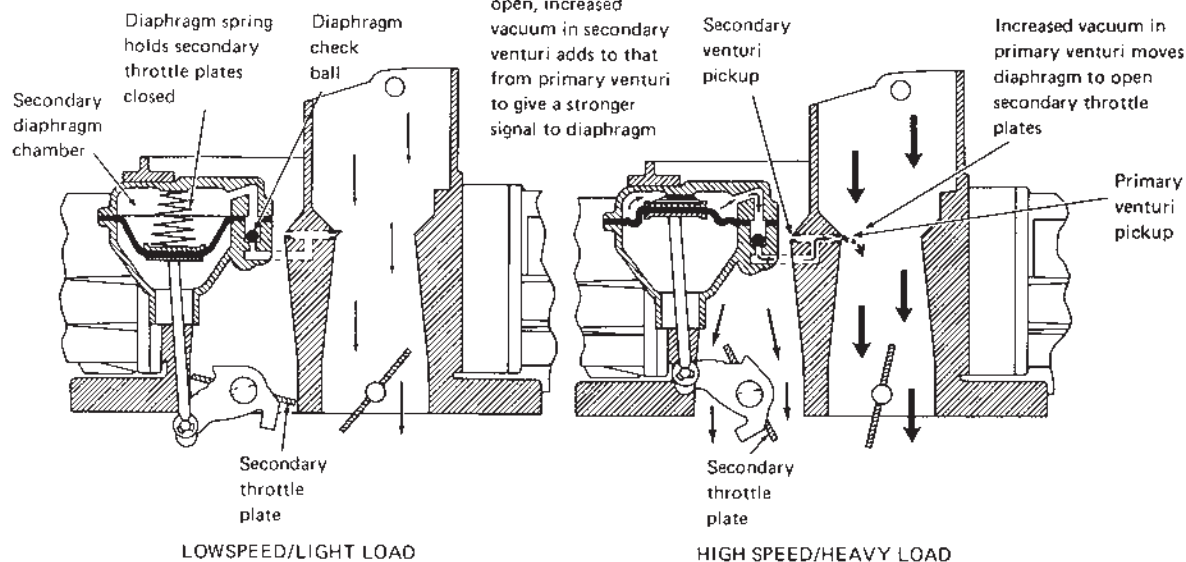

General Guidelines For Adjusting Brass And Nitrophenyl Floats

Two methods of float adjustment are provided for with Holley performance carburetors depending on the style of float bowl and needle and seat assembly employed. They are the internal (dry) setting and the external (wet) setting. The internal float adjustment is accomplished with the fuel bowl off the carburetor. With "internally adjustable" needle and seats, the fuel bowl is inverted and the float tang, or tab, is adjusted to the point where the float surface is parallel to the fuel bowl surface, just underneath. An initial dry setting can also be accomplished with "externally adjustable" needle and seats. To achieve this, invert the fuel bowl and turn the adjusting nut until the float surface lies parallel to the fuel bowl casting surface underneath.

Another, more accurate adjustment can be made with the side hung style float if measuring gauges, such as drill bits, are available. Here, with the fuel bowl inverted, the primary float can be adjusted to the point where there is a 7/64" gap between the "toe" of the float and the bottom of the fuel bowl surface underneath. The float "toe" is the part of the float furthest from where the arm is attached. The secondary float can be adjusted to the point where there is a 13/64" gap between the "heel" of the float and the bottom of the fuel bowl surface underneath. The float "heel" is the part of the float closest to the point where the arm is attached.

A "wet" level float adjustment can be performed on either the side or center hung floats, if the fuel bowls have provision for the externally adjustable needle and seats. This adjustment is made as follows. Start the vehicle up and move it out of the garage and into an open area where plenty of fresh ventilation is available. Allow the idle to stabilize. Turn the engine off and remove the sight plug from the primary fuel bowl to inspect the fuel level. If it's been determined that adjustment is required use a large screw driver to crack loose the lock screw. With a 5/8" open-end wrench turn the adjusting nut clockwise to lower the float level.

Conversely, turn the adjusting nut counter-clockwise to raise the float level. Tighten the lock screw. Restart the vehicle and let the engine idle stabilize. Shut the engine off. Remove the sight plug to reinspect the fuel level. The fuel level should stabilize at just below the level of the fuel bowl sight plug hole. This same adjustment procedure is performed on the secondary bowl.

NOTE: The float adjustment feature on Holley carburetors cannot cure a poor running engine, a bad ignition system, a clogged fuel filter, an improperly operating fuel pump or fuel pressure that is too high or low. This adjustment is provided solely to ensure that the fuel in the bowl can be adjusted to the correct level for the carburetor to perform its function. There is no need to "wrench" excessively on the adjustment nut. A quarter of a turn one way or the other should be enough to bring you into spec.

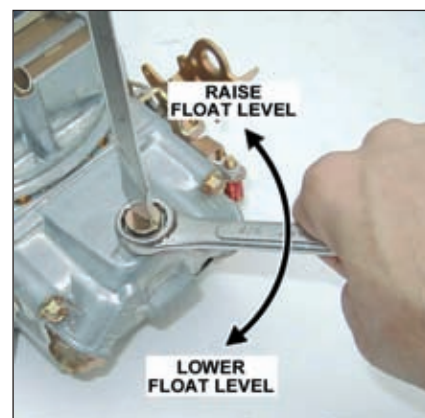

Terms and Definitions of Fuel Injection Management Systems

Throttle Body Assembly (TBA) — The throttle body assembly (also called air valve), controls the airflow to the engine through one, two or four butterfly valves and provides valve position feedback via the throttle position sensor. Rotating the throttle lever to open or close the passage into the intake manifold controls the airflow to the engine. The accelerator pedal controls the throttle lever position. Other functions of the throttle body are idle bypass air control via the idle air control valve, coolant heat for avoiding icing conditions, vacuum signals for the ancillaries and the sensors.

Fuel Injector — There are basically three approaches in delivering the fuel to the engine:

- Above the throttle plate as in throttle body injection
- In the intake port toward the intake valves as in multi-port injection or central multi-port injection.
- Directly into the combustion chamber as in gasoline direct injection systems (GDI).

The fuel injector is continuously supplied with pressurized fuel from the electric fuel pump. The pressure across the metering orifice of the injector is maintained constant by the fuel pressure regulator. The fuel injector is an electromagnetic valve that when driven by the ECU delivers a metered quantity of fuel into the intake manifold (or combustion chamber in the GDI system). The ECU controls the fuel flow by pulse width modulation. The time the injector is driven into an open condition is determined by the following sensor inputs:

- Engine RPM
- Throttle position (TPS)
- Manifold absolute pressure or mass air flow
- Engine coolant temperature
- Oxygen sensor feedback voltage
- Intake air charge temperature
- Battery voltage

Central Point Injection System (CPI) — Electronic fuel Injection system consisting on a single fuel injector mounted in the throttle body.

Digital Fuel Injection (DEFI or DFI) — Electronic fuel injection system controlled by digital microprocessors as opposed to earlier systems that were of analog design. The analog input signals to the microprocessor are converted from analog to digital before being processed.



THROTTLE BODY INJECTION (TBI) — In TBI systems the throttle body assembly has two major functions: regulate the airflow, and house the fuel injectors and the fuel pressure regulator. The choices of throttle bodies range from single barrel/single injector unit

generally sized for less than 150 HP to four barrel/four injector unit capable of supporting fuel and air flow for 600 HP. The injectors are located in an injector pod above the throttle valves. The quantity of fuel the injector spray into the intake manifold is continuously controlled by the ECU. Most of the TBI systems use bottom fed fuel injectors.

MULTI-POINT FUEL INJECTION (MPFI) — In the multi point fuel injection system an injector is located in the intake manifold passage. The fuel is supplied to the injectors via a fuel rail in the case of top fed fuel injectors and via a fuel galley in the intake manifold in the case of bottom fed fuel injectors. MPFI systems provide better performance and fuel economy as compared to TBI. Most of the MPFI systems use one injector per cylinder but in certain applications up to two injectors per cylinder are used to supply the required fuel for the engine.

CENTRAL MULTI-PORT FUEL INJECTION (CMFI) — This is a variation of MPFI system but in this case the injectors (usually one per cylinder) are located in a plastic molded pod and the fuel is distributed to the intake ports via a polymeric hose. To avoid fuel distribution variations a fuel pressure activated poppet valve is installed at the end of the hose. The injectors are activated via the ECU in a similar fashion as in the MPFI fuel systems.

TUNED PORT INJECTION (TPI) — A TPI is a fuel/air management system that has a tuned induction system to optimize airflow to each cylinder. This system was developed to obtain the broadest possible torque curve. A single throttle body and one injector per cylinder are used in this configuration. The intake manifold incorporates long runners whose length is tuned to the desired torque curve. For low and mid range torque longer runners are utilized in this application.

DIRECT FUEL INJECTION (DFI) — In a direct fuel injection system one injector is located in the cylinder head for each cylinder. The high-pressure fuel (single fluid) or low-pressure air/fuel mixture (dual fluid) is metered directly into the combustion chamber when the electromagnetic valve is activated by the ECU. This fuel injection system offers the latest in engine management systems and offers the best in engine performance, low exhaust emissions and fuel economy.

Electronic Control Unit (ECU) — The function of the ECU is to “tweak” or “fine tune” the engine operation to obtain the most complete and efficient combustion process. The ECU microprocessor receives input signals from various sensors from the engine and generates specific outputs to maintain optimum engine performance. The engine operating modes controlled by the ECU is the following:

- Cold and hot start
- Acceleration enrichment
- Battery voltage compensation
- Deceleration cut/off or enrichment
- Run mode (open loop or closed loop)



Manifold Absolute Pressure Sensor (MAP) — The MAP sensor is a three-wire sensor located on or attached to the intake manifold. The function of this sensor is to measure the changes in the intake manifold

air pressure and generates an electric signal that is proportional to the change of pressure. This signal is fed into the ECU and is used to:

- Adjust the fuel delivery
- Spark ignition calculations
- Barometric pressure readings upon starting the engine

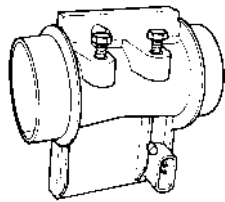

Mass Air Flow Sensor (MAF) —

The mass air flow sensor is positioned in the air intake duct or manifold and measures the mass of incoming air. From this acquired data the ECU calculates the required fuel for the specific air mass flow rate. The MAF works on the hot wire or hot film concept. The hot wire/film is maintained at a constant calibrated temperature. The

passing air cools down the hot wire/film and the added energy required to maintain the calibrated temperature is directly proportional to the mass of air passing by the hot wire. The MAF also compensates for humidity as humid air, denser or cooler, absorbs more heat from the sensor, requiring more current to maintain the calibration temperature.

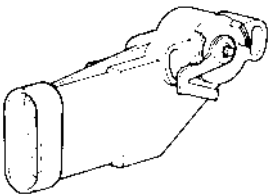

Throttle Position Sensor (TPS) — The TPS is a three-wire sensor that is mounted on the throttle body assembly and is actuated by the throttle shaft. The TPS is basically a variable resistor (potentiometer) that sends a voltage signal to the ECU that is proportional to the throttle shaft rotation. When the throttle shaft is open the sensor emits a high voltage signal and when the throttle shaft is closed it emits a low voltage signal. The voltage signal from the TPS changes between 0.45 V at idle to 4.5 to 5.0V at wide open throttle.

Open Loop — Open loop defines the engine operation where the fueling level is calculated by the ECU with only the input signals from the throttle position sensor (TPS), from the coolant and/or air charge temperature, and from the manifold absolute pressure (MAP) or the mass air flow sensor (MAF).

Closed Loop — Closed loop defines the engine operation where the fueling level is calculated and corrected by the ECU based on the voltage signal from the O₂ sensor. When the O₂ sensor emits a voltage signal above 0.45V due to a rich mixture in the exhaust manifold, the ECU reduces the fueling level by reducing the pulse width of the injector. The O₂ sensor voltage is the feedback that modifies the fuel control program that is based on other signals.

Idle Air Control Valve (IACV or IAC)

— The IAC is located in the throttle body of the TBI, MPFI and CMFI systems. The valve consists of a stepper motor that adjusts the position of its pintle to vary the bypass air during idle and off idle conditions. During the closed throttle condition (idle), the ECU constantly compares actual engine speed with the programmed desired engine speeds. Discrepancy between these two values result in activation of the stepper motor increasing or decreasing the bypass air around the throttle plate(s) until desired engine speed is achieved. The following input signals or conditions determine the position of the valve:

- Throttle position sensor
- Engine load (MAP/MAF, A/C compressor, power steering pressure switch, gear selection)
- Battery Voltage
- Engine coolant temperature

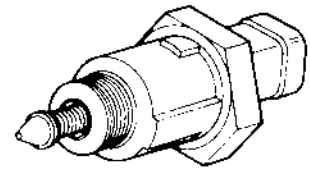

Throttle Air Bypass Valve — The throttle air bypass valve is located on the throttle body of engine fuel management systems. This solenoid valve allows additional bypass air when the engine is subjected to certain load conditions or cold starts.

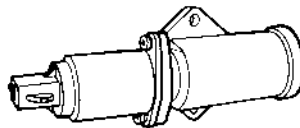

Air Charge Temperature Sensor — The air charge sensor is located in the engine air intake to sense the air induced into the engine manifold. The sensor consists of a thermistor, which generates a voltage signal, that is proportional to the air temperature. This voltage signal is used by the ECU to calculate the air density and using these results to adjust the fueling levels for a particular engine load. Other functions of the air temperature signal are:

- Adjust fueling during cold start
- Activation of the EGR valve
- Modify spark advance
- Regulate acceleration enrichment

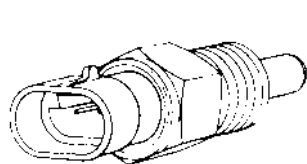

COOLANT TEMPERATURE SENSOR — The coolant temperature sensor is a two-wire sensor that is threaded into the engine block and is in direct contact with the coolant. The

function of this sensor is to generate a signal that the ECU uses to adjust the fueling levels required for the operation of the engine and operate ancillaries. The thermistor contained in the sensor generates an electric signal that is proportional to the coolant temperature. At low temperatures the resistance is high (3800 ohms) generating a 5-volt signal in the ECU. At normal engine operating temperatures the resistance of the sensor is low (180–200 ohms) which generates 1–2 volt signal in the ECU. Other functions of the coolant temperature signal are:

- Idle speed adjustment via the IAC
- Modify spark advance
- Electric cooling fan operation
- Activation of the EGR
- Torque converter clutch application

Oxygen Sensor — The oxygen sensor is located in the exhaust manifold and its function is to measure the oxygen content in the exhaust gases. The sensor is an electrochemical cell, which develops a voltage signal between its two electrodes that is proportional to the oxygen content in the exhaust gases. The oxygen sensor adjusts and maintains an optimum air fuel mixture to control the exhaust emission and the fuel economy. When the oxygen content in the exhaust is high due to a lean mixture the output voltage of the sensor is close to zero. If the fuel air mixture is on the rich side, the oxygen content in the exhaust is low and the output voltage of the sensor approaches 1.0 volts. There are three types of oxygen sensors:



- One wire O₂ sensor (not heated)
- Three wire O₂ sensor (heated)
- Four wire O₂ sensor (heated)

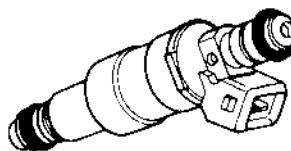
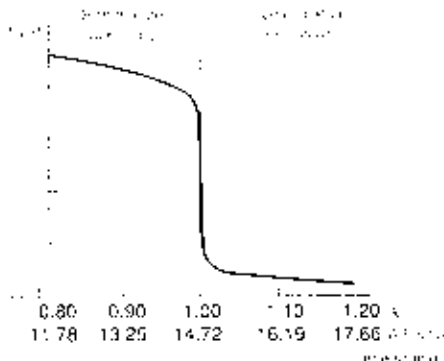

Top-Fed Fuel Injector — When the ECU activates this electromagnetic valve, the injector meters and atomizes fuel in front of the intake valve. The fuel enters the top and is discharged via the metering orifice at the bottom at high pressure. The spray geometry and cross sectional area is specific to the engine application. In general there are four major spray patterns:

- Pencil stream. Solid stream narrow angle spray.
- Split pencil stream. Two solid streams narrow angle sprays usually used in multi valve cylinder applications.
- Bend spray. Solid stream narrow angle spray being discharged in an angle with respect to the injector center axis. This application is used in engine applications where the injector package does not allow alignment of the injector axis with the spray target center axis.
- Oblong spray. This spray geometry consists of an elliptical or oblong cross-sectional area of the spray. This application is used in engine applications where the spray target requires a specific spray pattern.

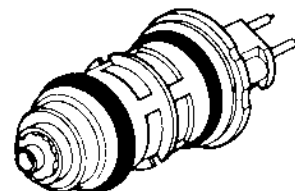

Bottom Fed Fuel Injector — This electromagnetic valve meters fuel into the intake manifold in proportion to the air flowing into the engine. When the valve is energized the electromagnetic force generated by the solenoid lifts the pintle/ball from the seat. Fuel under pressure is then injected into the throttle body bore or the intake port. The spray configuration is application dependent. For throttle body injection a hollow conical spray is required while for port injection a narrow pencil stream is preferred to avoid wall wetting.

High Impedance Injectors — Most injectors can be divided into two major categories: high impedance 12 to 16 Ohms and low impedance 1.2 to 4.0 Ohms. The high impedance injectors are used with ECUs that are designed with saturation drivers. The advantage of using saturation drivers is that the currents running through the ECU circuits and the injectors are relatively low thus generating less heat. The disadvantage of saturation drivers is that the driver has a slower response time, which could affect the full utilization of such a system at very high engine RPM.

Low Impedance Injectors — The low impedance injectors are designed to be run with an ECU that employs peak and hold drivers (also called current sensing or current limiting drivers). The current ratio (peak to hold) is generally 4:1 and the most common drivers available are 4 A peak/1 A hold or 2 A peak/ 0.5A hold. The peak current is generated to overcome the inertia of the closed valve and once the valve is open the driver cuts down to 1/4 of the peak current to hold the injector open until the end of the metering event. Low impedance injector designs are mostly used in high flow applications.

ELECTRIC IN-LINE FUEL PUMP — The function of the electric fuel pump is to deliver pressurized fuel to the fuel injection system. The ECU activates the fuel pump relay to operate the fuel pump when the ignition switch is in the On or start position. The pumps are designed to match certain flow and pressure specification for the engine application. In TBI applications the fuel pump must supply enough fuel flow for the engine WOT output at 15 to 20 psi. In multi-port applications the fuel pump must be able to supply enough fuel at full engine load to maintain at least 43.5 psi at the fuel rail. At idle the fuel pressure regulator must be able to return the excess fuel to the tank and maintain the required system pressure. Most of the cars prior to 1987 use an in-line external electric fuel pump.

ELECTRIC IN-TANK FUEL PUMP — Almost all car applications after 1987 designed their fuel pump assembly inside the fuel tank. The advantage of having the fuel pump in the fuel tank is mainly lower noise, lower potential leakage problems, less mounting sensitivity of the pump with respect to lift of fuel from the tank is minimized. The in-tank pump went through several designs evolving from a simple “pump on a stick” to a complex in-tank fuel sending modules. The new designs combine the high-pressure electric fuel pump, noise isolation and a fuel level sensor into one compact modular package. This new design also helps reducing hydrocarbon emissions. The hot gasoline returning from the fuel system is returned to the reservoir surrounding the fuel pump. By returning the hot fuel to the reservoir heating of the bulk fuel in the fuel tank is avoided, thus reducing the evaporation of the high volatile portions in the fuel. At present all fuel tank modules are designed and serviced as a complete unit. If the pump or fuel level sensor fails the entire unit will have to be changed.



FUEL PUMP INLET FILTER — The function of this filter is to eliminate any impurities that might harm the fuel pump. In the in-line fuel pump type this filter is external to the fuel tank and is in a replaceable cartridge filter. In the in-tank fuel pumps the fuel filter is in the form of a sock and is directly attached to the pump in the “pump on a stick” version and attached to the fuel pump module in the module version.

MAIN FUEL FILTER — The function of this filter is to eliminate any contaminants after the fuel pump. These are either small enough to pass through the fuel filter of the pump inlet or are generated by the pump inlet or are generated by the fuel pump. This fuel filter is also of the cartridge type but is designed to sustain much higher fuel pressures than the fuel pump inlet filter.

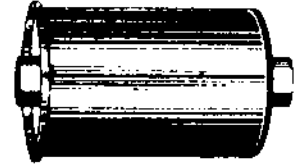

FUEL PRESSURE REGULATOR — Fuel system pressure is maintained by the regulator, while excess fuel is returned to the fuel tank. The regulator consists of two chambers separated by a diaphragm assembly. On the fuel side of the diaphragm a throttling valve is employed to expand or restrict fuel flow as the fuel pressure fluctuates. The other side contains a spring with an adjustment screw that is set at the factory for correct system pressure and flow. This chamber is connected to the intake manifold in MPFI systems to reference the vacuum in the manifold during engine operation. This pressure reference is required to maintain a constant differential pressure across the metering orifice of the fuel injector.

THE ENGINE APPLICATION AND THE SELECTION OF YOUR FUEL MANAGEMENT SYSTEM COMPONENTS.

Injector Fuel Flow

Engine output is in direct relation with fuel supplied to the engine, however installing injectors, which are too big, will not make more power. It is therefore very important to match the fuel injector flow characteristics to specific engine applications. Matching the fuel flow characteristics of fuel injectors is as important as matching the carburetor jets for a specific engine application. The fuel flow of the injectors and the carburetor has to be matched to the air flow requirements of the engine over a broad RPM operating range.

In the carburetor the operating range is usually divided into three sub-ranges: idle, mid-range and power. Three distinct fuel circuits supply the fuels for these three ranges. In MPFI systems one single injector has to cover all three ranges for individual cylinders from 500 RPM at idle to 8000 at WOT. The operating range in fuel injectors is normally referred to as the dynamic range of the injector. An injector with a wide dynamic range is capable not only to potentially cover several engine applications but also is a very sought after metering tool for high performance applications.

The dynamic range must encompass the minute quantities of fuel required at idle conditions and the large quantities of fuel required at maximum engine output. It must also cover the required fuel amounts during transient response. The dynamic range of the fuel injector is further stressed in turbo charged applications because of the additional fuel required due to the higher engine air mass flow rates generated by the turbocharger.

The following equation sizes fuel injectors for specific engine applications.

$$\text{Injector Static Flow Rate [lb/hr]} = (\text{Engine HP} * \text{BSFC}) / (\text{Number of injectors} * \text{DC of Inj.})$$

Engine HP = Realistic HP output estimate of the engine

BSFC = Brake Specific Fuel Consumption [lb/HP*hr].
Good approximation 0.50

Duty Cycle of Injector = Maximum opening time of injector/cycle time.

Maximum Duty Cycle= 0.90

Example:

Engine HP = 400HP

Number of Injectors = 8

$$\text{Injector Static Flow Rate [lb/hr]} = (400 * 0.50) / (8 * 0.90) = >27.78 \text{ b/hr}$$

Note: If the application requires a static flow rate that falls in between two available injectors always use the next injector with the higher flow rate.

For the example above if only 25 lb/hr and 30 lb/hr injectors are available, choose 30lb/hr injectors.

Fuel pressure

In certain occasions matching of the injectors' fuel flow for a specific engine application cannot be done due to injector availability or the fuel flow step between the available injectors is too large. Since the fuel injector is a pressure/time-metering device, increasing the fuel pressure can increase the fueling level. Increasing the fuel pressure is limited mainly to four factors: burst pressure of the components in the fuel system, increase of opening time of the injector, reduced life expectancy of the fuel system components and limitations of the fuel pump. Most injectors are limited to a burst pressure of 125 psi. Reducing the fuel pressure to match the required fuel flow can be done but lower fuel pressures affect the atomization efficiency of the fuel injector nozzle. To project potential fueling levels by changing the fuel pressure, the following equation can be used:

$$M1/M2 = \sqrt{P1} / \sqrt{P2}$$

M1 = rated mass flow rate of the injector at fuel pressure P1 in lb/hr

M2 = new mass flow rate of the injector at fuel pressure P2 in lb/hr

P1 = existing fuel pressure setting in psi

P2 = new fuel pressure setting in psi

Example:

Rated mass flow rate M1 = 30 lb/hr

Existing fuel pressure P1 = 43.5 psi

Required fuel mass flow rate M2 = 35 lb/hr

$$P2 = (M2/M1)^2 * P1$$

$$P2 = (35/30)^2 * 43.5$$

$$P2 = 59.21 \text{ psi} = >60 \text{ psi}$$

To obtain a fueling level of 35 lb/hr the system pressure has to be increased to 60 psi.

After increasing the fuel pressure to obtain certain engine output, idle, off-idle and light load condition will have to be re-tested. Increasing the fueling level at the upper end, requires the fuel injector to run at smaller pulse widths at idle conditions. When running at pulse widths smaller than 1.8 ms the injector might be running in the non-linear portion of its dynamic range. Such condition can lead to engine "hunting" during idle to hesitation during off-idle conditions.



HOW TO CHOOSE A CARB
STREET CARBURETORS
SUPERCHARGER CARBURETORS
RACE CARBURETORS
MARINE CARBURETORS
CARB SERVICE PARTS & ACCESSORIES
FUEL INJECTION
THROTTLE BODIES
FUEL PUMPS
INTAKE MANIFOLDS
CYLINDER HEADS
SYSTEMAX
ENGINE DRESS-UP
MERCHANDISING
TECHNICAL INFORMATION
INDEX

Proper Fuel Injector Selection Information

Choosing the proper fuel injector size is critical for the successful use of an electronic fuel injection system whether it be a TBI or Multi-port system. If an injector is too small, not enough fuel will be available when tuning an engine and damage can result. If an injector is selected that is much larger than is needed, the injector pulse width (time the injector is open) at idle may be too low and tuning problems at idle may occur.

Use the following information as a guide for selecting the correct injectors for an engine:

Formulas used to determine injector size:

$$\text{Injector Size} = \frac{(\text{Engine HP (Flywheel)}) \times (\text{BSFC})}{(\# \text{ of injectors}) \times (\text{Duty Cycle})}$$

Injector Size Flow rate in lbs/hr

Engine HP Maximum horsepower at the flywheel

BSFC Brake Specific Fuel Consumption (BSFC) is the lbs. of fuel an engine consumes per HP per hour. It is simply a measure of how efficiently an engine is at converting fuel to horsepower. It is very important to use a BSFC number that is close to your actual number. If it is not, the injector will be too small or larger than is necessary.

General guidelines when choosing a BSFC number:

- Low to medium performance street engines: 0.50-.55
- Performance engines with good cyl. heads: 0.45-.50
- Race engines with very efficient cyl. heads: 0.38 - 0.45
- Supercharged and Turbocharged engines: 0.55 - 0.65

Supercharged and Turbocharged engines run at richer air/fuel ratios that raise the BSFC number. They require larger injectors for the same horsepower as a naturally aspirated engine.

Add 0.05 for marine applications, as they need to run richer than a comparable automotive application due to continuous wide open throttle use.

Duty Cycle The duty cycle is the maximum amount of time you want the injectors to be open at a certain horsepower and injector size. Under most circumstances you don't want an injector to be open more than 90% of the time at the most. Marine applications shouldn't exceed 80%. Injectors are rated at 100% duty cycle (static flow).

Later on if you want to increase the the engine HP, take that into account when entering the HP number.

When calculating injector size, round up to the next nearest size needed. For example if you calculate 26 lb/hr and have a 24 lb/hr and a 30 lb/hr to choose from, select the 30 lb/hr injector.

Examples

400 HP street engine
Number of injectors = 8

$$\text{Injector size} = \frac{(400 \text{ HP}) \times (0.5 \text{ BSFC})}{(8 \text{ injectors}) \times (0.9)} = 27.7 \text{ lb/hr}$$

600 HP Supercharged engine
Number of injectors = 8

$$\text{Injector size} = \frac{(600 \text{ HP}) \times (0.57 \text{ BSFC})}{(8 \text{ injectors}) \times (0.9)} = 47.5 \text{ lb/hr}$$

The following chart provides maximum horsepower levels based on injector size and various BSFC values. Note that this is at 100% duty cycle and 43.5 psi; raising the fuel pressure will increase the maximum horsepower.

Inj. Size	Max. HP at given BSFC (100% duty cycle, 43.5 PSI)				
	0.4	0.45	0.5	0.55	.06
14	280	250	225	203	186
19	380	337	304	276	253
24	480	426	384	349	320
30	600	533	480	436	400
36	720	640	576	523	480
42	840	746	672	610	560
50	1000	888	800	727	666
55	1100	977	880	800	733
65	1300	1155	1040	945	866
75	1500	1333	1200	1090	1000
85	1700	1511	1360	1236	1133
95	1900	1688	1520	1381	1266

Fuel Pumps / Regulator Technical Information



Fuel line sizes



Holley offers a wide selection of both mechanical and electric fuel pumps for a variety of street performance and race applications. Selecting the proper fuel pump for your vehicle, however, begins with understanding your engine's fuel requirements.

Fuel Requirements

Typically, at wide open throttle, full power, an engine requires 0.5 lbs. of fuel per horsepower every hour. A gallon of gasoline weighs approximately 6 lbs. Therefore an engine rated at 350 horsepower will require about 175 pounds (29 gallons) of fuel every hour.

$$(350\text{HP} \times .5 \text{ lbs} = 175 \text{ lbs of fuel})$$

$$175 \text{ lbs}/6 \text{ lbs} = 29 \text{ gallons per hour}$$

Fuel Pressure and Volume

The relationship of pressure to volume is inversely proportional. That is, as pressure increases the volume will decrease, everything else being equal. A certain amount of fuel pressure is always required to maintain engine performance by assuring that fuel is available on demand. Also, other factors and conditions must be taken into account such as acceleration G-forces and friction within the fuel system itself. At the same time, however, an adequate fuel volume is needed to ensure that the proper amount of fuel can always flow to the engine, especially during peak demand situations. A basic understanding of this critical pressure/volume relationship is needed when designing the proper fuel supply system for your vehicle.

Fuel Line System

The fuel line system should be routed to avoid running near hot spots, such as various exhaust system components, and designed to promote maximum fuel flow. Most factory stock fuel systems utilize 5/16" fuel lines. This size works well on street applications with stock engines. When the horsepower requirements go up, however, the inadequacy of this line size soon becomes apparent. A #6 (3/8") line size is sufficient for all street performance applications and some racing applications. #8 (1/2") fuel lines are used on everything else, including alcohol applications. Avoid using rubber fuel lines, or use them sparingly, for two reasons. First, rubber is more resistant to the flow of fuel than any hard line. An actual pressure loss can be measured over distance. Second, for safety's sake, it's not a good idea to use rubber fuel line, especially when using a high pressure performance fuel pump.

Fuel Line Fittings

Like the fuel line, fuel line fittings are also a very important element in the total fuel line system and should not be overlooked. Obviously, the fittings should be the same size as the fuel line. Also, if at all possible, you want to minimize the use of 90° fittings. Avoid sharp turns or bends in the fuel line routing; these cause undue restrictions to the flow of fuel.



Mechanical Pumps

Various Holley mechanical fuel pumps are available. 110 GPH pumps are designed for street/strip applications where substantially higher than stock fuel delivery requirements are necessary. 3/8" inlet and outlet ports are utilized and, with fuel shut-off pressure in the area of 6-1/2 - 8 PSI, a regulator is not required. 130+ GPH pumps are available when maximum fuel delivery is desirable. 1/2" inlet and outlet ports are included and fuel shut-off pressure is between 7-1/2 - 9 PSI. A pressure regulator is definitely required. Both the 110 GPH and 130+ GPH pumps utilize a high capacity fuel valve design that will ensure an adequate fuel supply is always available.



Electric Pumps

Holley offers a complete line of electric in-tank and externally-mounted pumps.

Holley externally-mounted electric fuel pumps are also available in various flow ratings. The "red" pump, **P/N 12-801-1**, is rated at 97 GPH and it is designed to work with stock or mildly modified engines. Pressure is pre-set to 7 PSI and a regulator is not required. The "blue" pump, **P/N 12-802-1**, is rated at 110 GPH and it is designed for street/strip applications. Pressure is pre-set at 14 PSI and a regulator is included as part of the package. Neither pump is compatible with methanol or alcohol fuels nor should they be used with fuel injection systems. The "black" pump, **P/N 12-815-1**, is rated at 140 GPH and is designed to work with either gas or alcohol fuels. This one is similar to the "blue" pump but it kicks out more fuel. These pumps all feature a simple, yet rugged, rotor and vane design which has proved itself over the years.



Two powerful gerotor pumps are also available. Known as the HP Series, they are compatible with gas, alcohol or methanol. They are p/n 12-125, rated at 125 GPH, and p/n 12-150 which is rated at 150 GPH. These feature a gerotor pump design which pumps fuel effectively, yet quieter than a traditional vane style pump. Their base is made of hard anodized billet aluminum for long life and durability. Fuel pressure on the 125 is internally regulated to 7psi while the 150 is internally regulated to 15psi and comes with a 4-1/2 - 9psi regulator.



Our electric in-tank line offers coverage for the most popular Ford, Chrysler, GM and Import applications. Utilizing a proven gerotor design, these pumps are available in either a 190 or 255 liter per hour (lph) flow rate.

Flow Chart for Externally Mounted Electric Fuel Pumps

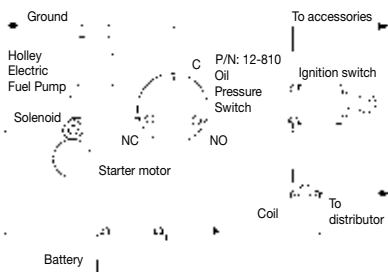
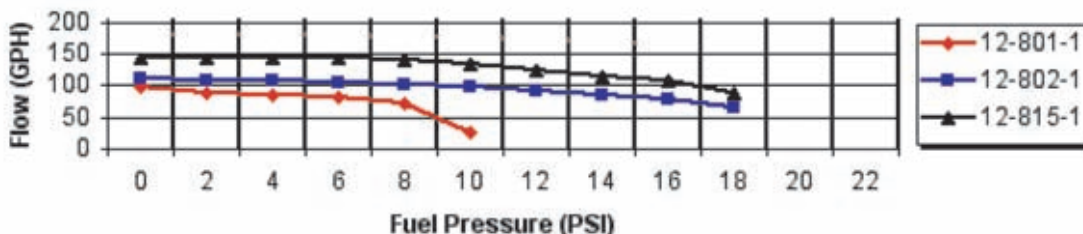

OIL PRESSURE SAFETY SWITCH

It's always a good idea to place a safety switch in the circuit when installing an electric fuel pump. Holley has one available under P/N 12-810. This switch will ensure that the electric pump will not work unless the engine has oil pressure. It will prevent the pump from running in a situation where the motor may stall with the ignition ON. Wiring the switch through the starter solenoid circuit energizes the pump on engine start-up. After the engine is running the switch continues to provide power to the pump as long as there is oil pressure to keep the switch turned on. (SEE ILLUSTRATION)

FUEL PRESSURE GAUGES

There are a number of places where mechanical fuel pressure gauges could be effectively mounted. One place is just before the carburetor. Holley chrome dual feed fuel lines (except model 4500 DOMINATOR) and fuel blocks all have a tapped 1/8 NPT provision for this purpose. Another would be at the outlet side of the pressure regulator. The Holley four-port Pro-Series VOLUMAX regulator incorporates two pressure gauge taps expressly for this purpose. The electric fuel pressure gauge can be mounted inside the vehicle so that fuel pressure can be monitored while driving. This is possible because, unlike the mechanical gauges, fuel does not flow up to the gauge itself. The Holley electric gauge, P/N 26-503, utilizes a remote sending unit which is the primary fuel pressure sensor.



Holley offers a variety of fuel pressure gauges, depending on use. For carbureted vehicles there are two (2) mechanical and one (1) electric gauge available in the 0-15 PSI range.

Vehicles equipped with low pressure (up to 30 PSI) fuel injection systems (like throttle body fuel injection systems) can choose from two mechanical pressure gauges in the 0-30 PSI range.



Fuel Filters

What's the use of designing and building a good fuel line system and then choke it down with a restrictive fuel filter? It just doesn't make sense. Therefore, the fuel filter is another important consideration when building and designing your fuel system. A filter that's too small for a particular system is a potential high restriction area that will hinder performance by not allowing the fuel pump to perform to its maximum. Holley offers standard in-line filters that can be used on the street. For the Pro-Series VOLUMAX fuel pumps, Holley recommends using either Holley P/N 162-514 or 162-515 VoluMAX filters.



Fuel Pressure Regulators

The needle and seat assemblies that are installed in Holley performance carburetors can satisfactorily control fuel pressure up to about 8 PSI. If the fuel pump is putting out more than 8 PSI, a regulator should be used to keep the fuel pressure within safe limits and avoid the possibility of flooding. Holley manufactures a number of regulators for most any need. A street regulator is available in either (P/N 12-804) or a chrome finish. A performance regulator is available in (p/n 12-803) a chrome finish. Both regulators feature a 3/8" NPT inlet port and two 3/8" NPT outlet ports with a .220" restriction (7/32"). The street version regulates pressure from 1 to 4 PSI while the performance version regulates pressure from 4-1/2 to 9 PSI. NOTE: These regulators are designed to work with a single carburetor installation. If two carburetors are used then two regulators will be required, one for each carburetor.



Holley also offers two VOLUMAX regulators. The first, P/N 12-704, is basically a larger version of the two previously mentioned regulators but with more flow capacity. This regulator features a single 1/2" NPT inlet port and two 1/2" outlet ports with a .437" restriction (7/16"). Fuel pressure is regulated from 4-1/2" to 9 PSI. The other regulator, P/N 12-707, is designed for dual carburetor installations. It features four " -6" AN (approximately 3/8") outlet ports and one " -8" AN (approximately 1/2") inlet port with a .437" (7/16") restriction. Three 1/8" NPT fuel pressure gauge ports are also included. Without a doubt these two Pro-Series regulators are the least restrictive, highest flowing, production regulators currently available.



INSTALLATION TIP - for vehicles without fuel return line to the tank: Install the regulator close to the carburetor. Fuel lines from the regulator to the carburetor should be #6 (3/8").

Following are various fuel system schematics for street and race applications. Although intended only as a guide, these designs have been successfully used in many performance applications.

Figure 1 – One (1) #12-802-1, 12-150 or 12-815-1 “blue” pump feeding single carburetor, without fuel return line.

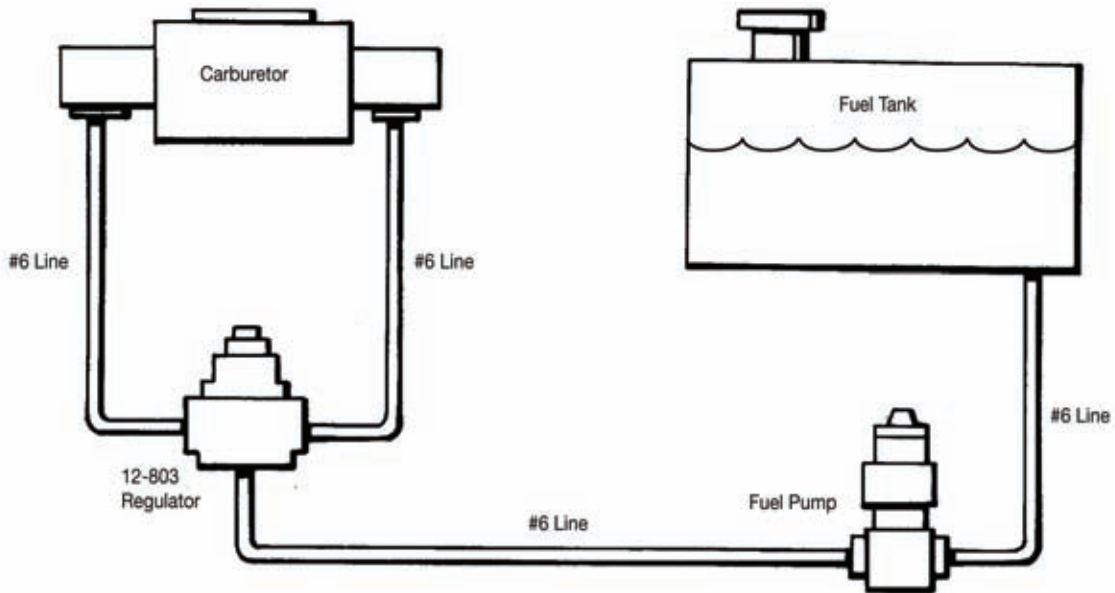
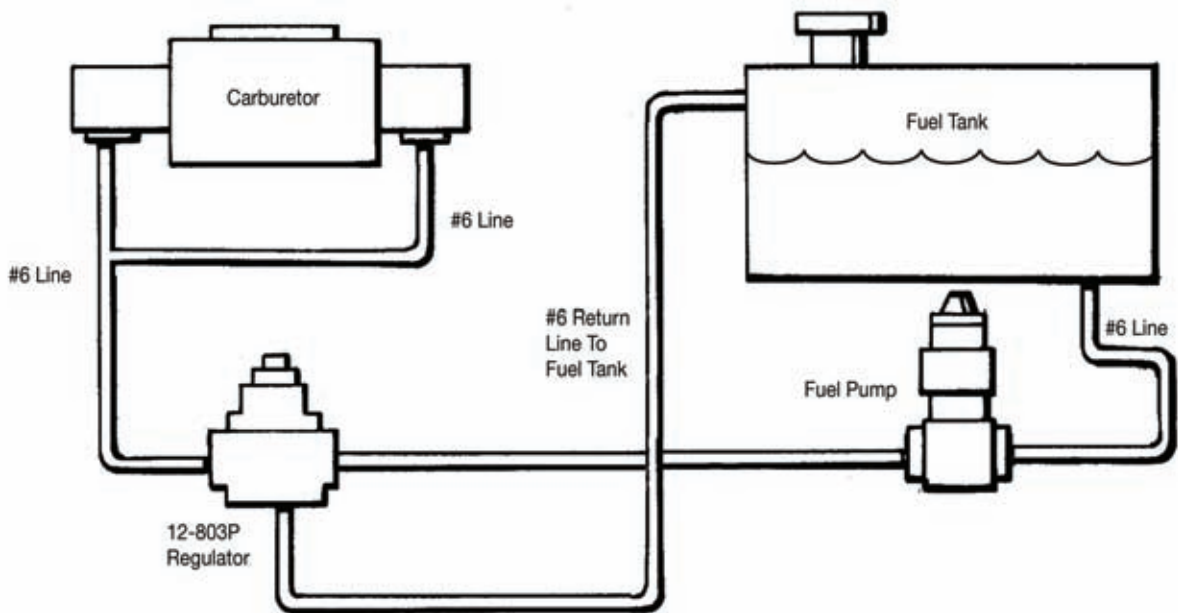

Figure 2 – One (1) #12-150, 12-802-1 or 12-815-1 pump feeding single carburetor.



HOW TO CHOOSE A CARB
STREET CARBURETORS
SUPERCHARGER CARBURETORS
RACE CARBURETORS
MARINE CARBURETORS
CARB SERVICE PARTS & ACCESSORIES
FUEL INJECTION
THROTTLE BODIES
FUEL PUMPS
INTAKE MANIFOLDS
CYLINDER HEADS
SYSTEMAX
ENGINE DRESS-UP
MERCHANDISING
TECHNICAL INFORMATION
INDEX

Figure 3 – Two (2) #12-802-1, 12-815-1 or 12-150 “blue” pumps feeding single carburetor.

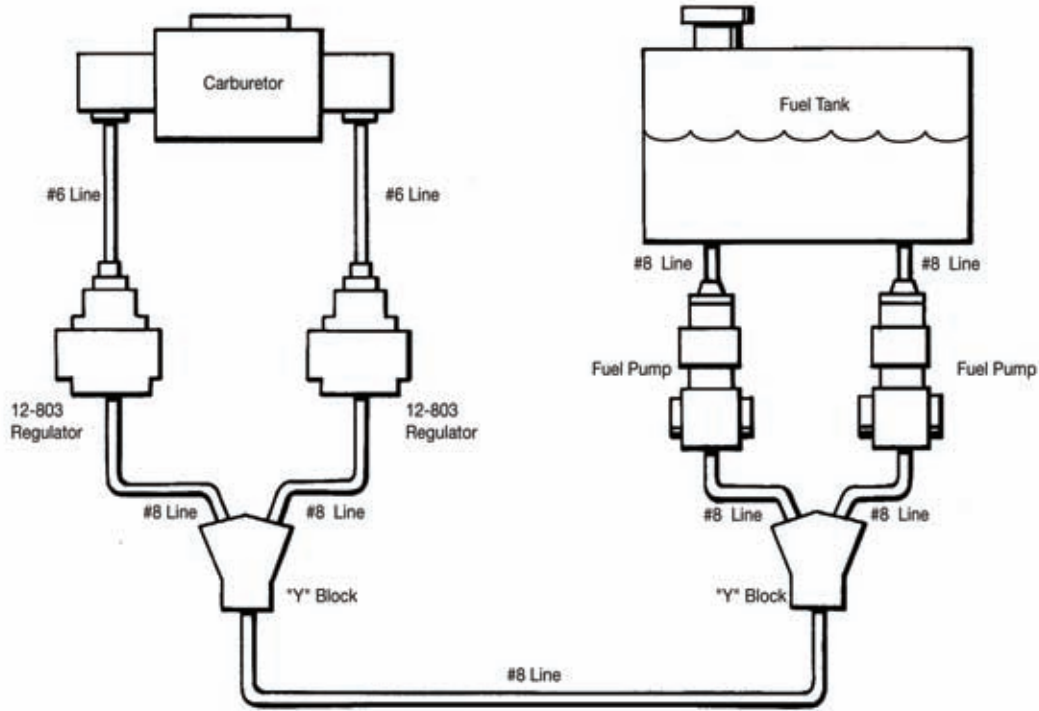
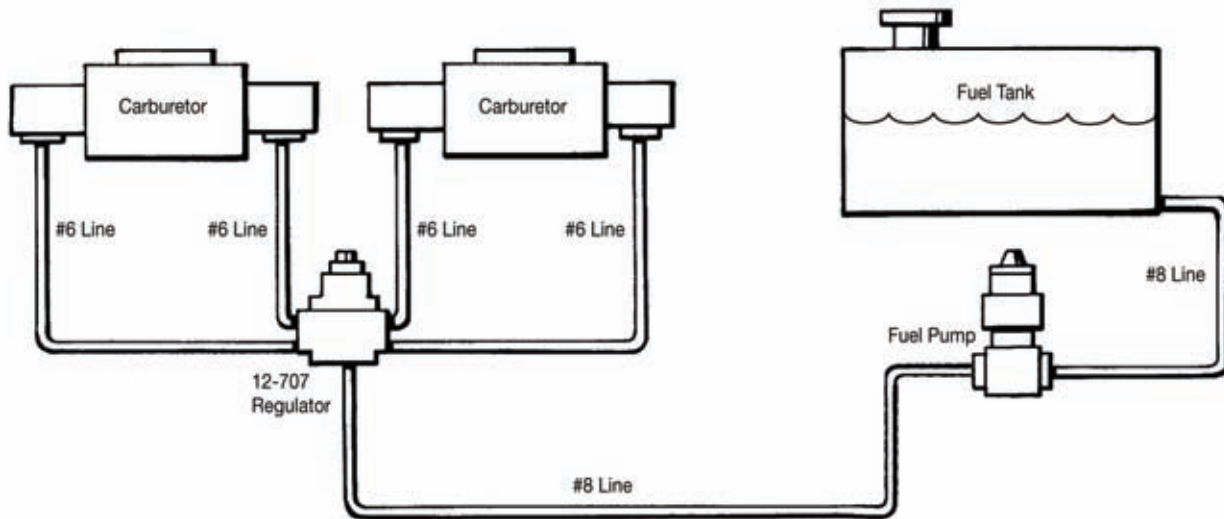

Figure 4 – One (1) #12-150, 12-802-1 or 12-815-1 pump feeding dual carburetors.



PART #	PAGE	PART #	PAGE	PART #	PAGE	PART #	PAGE
0-1848-1	12,22	0-80529-1	40,51	3-888	84	10-12028SV	138
0-18500	12,24	0-80531	12,30	3-1184	84	10-12060DANV	138
0-1850S	12,24	0-80532-1	44,58	3-1445	84	10-12060SANV	138
0-3310C	12,28	0-80535-1	40,52	3-1447	84	10-12060SV	138
0-3310S	12,28	0-80537	59,62	6-500-2	91	11-4	70
0-4144-1	31	0-80540-1	40,49	6-501-2	91	12-125	128
0-4224	38,50	0-80541-1	40	6-502-2	91	12-150	128
0-4235	31	0-80551	59,61	6-504	91	12-289-11	126
0-4236	31	0-80552	59,62	6-506	91	12-289-13	126
0-4365-1	31	0-80555C	12,25	6-508	91	12-289-20	126
0-4412C	10,23,36	0-80556-1	44,58	6-510	91	12-289-25	126
0-4412S	10,23,36	0-80559	59,61	6-511	91	12-289-30	126
0-4609-1	38,51	0-80570	14,23	6-513	91	12-289-35	126
0-4776C	18,25	0-80572S	34	6-515-2	91	12-327-11	126
0-4776S	18,25	0-80573S	35	6-518-2	91	12-327-13	126
0-4777C	18,26	0-80575S	34	6-519-2	91	12-327-20	126
0-4777S	18,26	0-80576S	35	10-4000	138	12-327-25	126
0-4778C	18,27	0-80577S	35	10-4000V	138	12-327-30	126
0-4778S	18,27	0-80583-1	36,48	10-4001	138	12-327-35	126
0-4779C	18,28	0-80586	57	10-4001V	138	12-360-11	126
0-4779S	18,28	0-80586-1	44	10-4002	138	12-389-11	126
0-4780C	18,30	0-80592S	34	10-4002V	138	12-390-11	126
0-4780S	18,30	0-80670	14,26	10-4010	138	12-440-11	126
0-4781C	18,30	0-80672	45,57	10-4010V	138	12-454-11	126
0-4781S	18,30	0-80673	45,58	10-4020	138	12-454-13	126
0-4790	31	0-80674	42,50	10-4020V	138	12-454-20	126
0-4792	31	0-80675	42,52	10-4028	138	12-454-25	126
0-6210	25	0-80676	42,55	10-4028V	138	12-454-30	126
0-7320-1	44,57	0-80681	27	10-4999	138	12-454-35	126
0-7448	10,22,36	0-80770	14,29	10-6000	138	12-454-40	126
0-8007	12,22	0-80783	25	10-6000V	138	12-454-40	133
0-8082-1	44,56	0-80783C	12	10-6001D	138	12-460-11	126
0-8896-1	44,56	0-80787-1	36,48	10-6001DV	138	12-460-13	126
0-9015-1	59,62	0-80870	14,31	10-6001S	138	12-704	135
0-9022	59,63	0-81570	14,23	10-6001SV	138	12-707	135
0-9375-1	44,57	0-81670	14,26	10-6001WS	138	12-751	140
0-9377-1	44,58	0-81770	14,29	10-6002D	138	12-752	140
0-9379	38,51	0-81870	31	10-6002DV	138	12-753	137
0-9380	38,54	0-82651	20,26,50	10-6002S	138	12-801-1	128
0-9381	38,54	0-82750	20,28,53	10-6002SV	138	12-802-1	128
0-80186-1	44,52	0-82751	20,29,53	10-6010	138	12-803	135
0-80318-1	59,61	0-83670	14,26	10-6010V	138	12-803BP	135
0-80319-1	59,60	0-83770	14,29	10-6020	138	12-804	135
0-80320-1	59,60	0-85670	14,26	10-6020V	138	12-805	139
0-80340-1	59,63	0-85770	14,29	10-6028D	138	12-806	139
0-80364	59,60	0-90470	16,22	10-6028DV	138	12-807	139
0-80402-1	59,60	0-90670	16,27	10-6028S	138	12-810	139
0-80443	59,63	0-90770	16,29	10-6028SV	138	12-811	139
0-80450	23	0-93670	27	10-6030S	138	12-812-1	128
0-80451-1	49	0-95670	16	10-6999D	138	12-813	116
0-80451	23	0-95770	16,30	10-6999S	138	12-813	140
0-80452	24	3-352	84	10-9000V	138	12-814	109
0-80453	24	3-358	84	10-9010V	138	12-814	116
0-80457S	12,24	3-396	84	10-9028DANPV	138	12-814	140
0-80492	59,61	3-466	84	10-9028DANV	138	12-815-1	128
0-80496-1	40,55	3-474	84	10-9028SANV	138	12-816	139
0-80498-1	40,55	3-485	84	10-9028SV	138	12-819	139
0-80507-1	40,48	3-539	84	10-9060DANPV	138	12-820	139
0-80508S	12,28	3-555	84	10-9060DANV	138	12-821	139
0-80509-1	40,54	3-588	84	10-9060SANV	138	12-832	126
0-80511-1	40,54	3-592	84	10-9060SV	138	12-833	126
0-80513-1	40,56	3-606	84	10-12000V	138	12-834	126
0-80514-1	40,56	3-670	84	10-12010V	138	12-835	126
0-80528-1	40,52	3-720	84	10-12028SANV	138	12-836	126

HOW TO CHOOSE A CARB CARBURETORS SUPERCHARGER CARBURETORS RACE CARBURETORS MARINE CARBURETORS CARB SERVICE PARTS & ACCESSORIES FUEL INJECTION THROTTLE BODIES FUEL PUMPS INTAKE MANIFOLDS CYLINDER HEADS SYSTEMAX ENGINE DRESS-UP MERCHANDISING TECHNICAL INFORMATION

INDEX

PART #	PAGE	PART #	PAGE	PART #	PAGE	PART #	PAGE
12-837	126	20-40	68	26-43	72	34-10	86
12-838	126	20-41	69	26-44	72	34-13	90
12-854	126	20-44	69	26-57	70	34-13S	90
12-860	126	20-45	69	26-59	68	34-16	77
12-900	131	20-47	69	26-68	75	34-24	75
12-901	131	20-48-1	68	26-68	93	34-25	75
12-902	131	20-49-1	68	26-69	72	34-26	75
12-904	131	20-53	68	26-69	85	34-27	75
12-905	131	20-54	68	26-70	72	34-32	95
12-906	131	20-55	68	26-71	72	34-34	95
12-907	131	20-58	69	26-73	72	34-36	95
12-909	131	20-59	95	26-74	72	34-37	75
12-910	131	20-60	69	26-75	72	34-38	75
12-911	131	20-64	68	26-76	72	34-39	77
12-912	131	20-65	68	26-77	72	34-150	77
12-913	131	20-67	68	26-85	75	34-160	77
12-914	131	20-72	69	26-86	72	34-500	75
12-915	131	20-73	95	26-88	140	34-501	75
12-916	131	20-77	95	26-89	75	34-502	75
12-917	131	20-78	65	26-90	140	34-503	95
12-918	131	20-80	65	26-93	68	34-504	65
12-919	131	20-81	65	26-94	68	34-505	65
12-920	108	20-85S	95	26-95	68	34-506	71
12-920	116	20-88	69	26-96	68	34-508	75
12-920	132	20-89	69	26-97	68	34-509	75
12-921	131	20-91	69	26-98	68	34-510	75
12-927	116	20-95	69	26-99	68	34-511	75
12-927	132	20-96	114	26-100	68	34-550	77
17-6	67	20-97	114	26-101	90	36-33	167
17-6	114	20-99	95	26-102	72	36-51-7	170
17-9	67	20-100	69	26-103	68	36-73	170
17-13	159	20-104	68	26-104-10	68	36-75	167
17-14	114	20-105	73	26-105	86	36-75	168
17-14	159	20-108-10	65	26-110-10	90	36-117	86
17-27	67	20-109-10	65	26-111-10	90	36-118	86
17-34	67	20-110-10	95	26-112	75	36-133	170
17-41	114	20-111	89	26-113	75	36-136	170
17-43	67	20-112	70	26-114	75	36-168	170
17-45	114	20-113	109	26-115	75	36-176	166
17-47	114	20-114	65	26-116	75	36-181	89
17-57	67	20-119	70	26-123	80	36-182	86
17-59	67	20-120	135	26-124	80	36-184	66
17-62	67	20-121	69	26-125	80	36-184	86
17-70	67	20-122	68	26-126	80	36-192	162
17-72	67	20-124	67	26-131	123	36-194	167
20-2	68	20-124	86	26-132	123	36-201	89
20-3	68	26-1	93	26-134	123	36-240	88
20-5	68	26-2	93	26-137	68	36-269	166
20-6	68	26-3	93	26-139	65	36-270	169
20-7	69	26-13	75	26-139P	65	36-277	167
20-7	116	26-18-2	72	26-140	65	36-322	89
20-9	69	26-23	65	26-140P	65	36-325	166
20-11	65	26-24	72	26-500	85	36-335	162
20-12	65	26-25	72	26-501	85	36-337	162
20-14	69	26-26	72	26-502	85	36-351	168
20-17	69	26-27	72	26-503	85	36-363	168
20-20	68	26-28	72	26-504	85	36-373	169
20-28	95	26-29	72	26-505	85	36-381	170
20-32	69	26-36	93	34-1	77	37-119	81
20-35	69	26-37	75	34-2	74	37-119	83
20-36	68	26-37	79	34-6	90	37-474	83
20-37	68	26-38	65	34-6S	90	37-485	83
20-38	68	26-39	75	34-7	91	37-605	83
20-39	68	26-41	66	34-9	95	37-720	83

PART #	PAGE	PART #	PAGE	PART #	PAGE	PART #	PAGE
37-754	83	108-28-2	79	112-508	122	121-125	66
37-933	81	108-34-2	79	112-508	123	121-131	66
37-933	82	108-35-2	79	112-509	122	121-132	66
37-934	83	108-37	67	112-509	123	121-135	66
37-935	83	108-37	78	112-510	123	121-137	66
37-936	83	108-40	79	112-511	123	121-140	66
37-1536	83	108-51	78	112-512	122	121-142	66
37-1537	83	108-52	78	112-512	123	121-145	66
37-1539	83	108-55-2	80	112-513	122	121-147	66
37-1539	84	108-56-2	80	112-513	123	121-150	66
37-1540	83	108-57	79	112-532	122	121-225	66
37-1541	83	108-58	78	112-535	122	121-228	66
37-1542	81	108-61	79	112-535	123	121-231	66
37-1542	82	108-62	78	112-538	109	121-237	66
37-1543	82	108-62	159	112-538	121	121-240	66
37-1544	82	108-67-20	79	112-540	123	121-325	66
37-1546	82	108-67-20	95	112-546	123	122-40	87
37-1547	82	108-70	79	112-547	123	122-41	87
43-106	108	108-71	78	112-548	122	122-42	87
43-106	116	108-71	159	112-549	122	122-43	87
45-223	70	108-73	78	112-550	123	122-44	87
45-223S	70	108-73	159	112-554	122	122-45	87
45-224	70	108-74	79	112-555	122	122-46	87
45-224S	70	108-76	78	112-555	123	122-47	87
45-225	71	108-77	75	112-556	122	122-48	87
45-225S	71	108-77	78	112-557	122	122-49	87
45-226	70	108-78	146	112-560	109	122-50	87
45-228	70	108-79	146	112-560	123	122-51	87
45-229	70	108-80	146	112-573	123	122-52	87
45-230	71	108-80	156	112-574	122	122-53	87
45-258	71	108-83-2	79	112-574	123	122-54	87
45-267	71	108-84-2	78	112-575	123	122-55	87
45-376	71	108-89-2	80	112-576	122	122-56	87
45-377	71	108-90-2	80	112-576	123	122-57	87
45-456	70	108-91-2	80	116-1	73	122-58	87
45-456	95	108-92-2	79	116-2	73	122-59	87
45-457	71	108-97	75	116-3	73	122-60	87
45-458	71	108-97	79	116-4	73	122-61	87
45-465	70	108-98-10	75	116-6	73	122-62	87
45-520	71	108-99	78	116-10	73	122-63	87
46-74	69	108-100	79	116-11	73	122-64	87
46-74	70	108-115	78	116-13	73	122-65	87
46-74	117	108-116	123	120-120	158	122-66	87
108-1	72	108-118	78	120-139	159	122-67	87
108-2-20	75	108-121	79	120-140	121	122-68	87
108-2-20	79	108-121	80	120-141	158	122-69	87
108-3	79	108-200	80	120-144	158	122-70	87
108-4	78	108-201	80	120-145	158	122-71	87
108-4	108	108-202	80	120-146	158	122-72	87
108-4	114	108-203	80	120-147	158	122-73	87
108-4	159	112-500	123	120-148	158	122-74	87
108-5	79	112-501	123	120-149	158	122-75	87
108-7	79	112-502	122	121-6	66	122-76	87
108-8	72	112-502	123	121-7	66	122-77	87
108-9	78	112-503	122	121-25	66	122-78	87
108-10	78	112-503	123	121-28	66	122-79	87
108-10	115	112-504	122	121-31	66	122-80	87
108-12	78	112-504	123	121-35	66	122-81	87
108-12	115	112-505	122	121-37	66	122-82	87
108-13-2	80	112-505	123	121-40	66	122-83	87
108-18	78	112-506	122	121-42	66	122-85	87
108-20	78	112-506	123	121-45	66	122-86	87
108-25	78	112-507	122	121-118	66	122-87	87
108-27-2	80	112-507	123	121-121	66	122-88	87

HOW TO CHOOSE A CARB STREET CARBURETORS SUPERCHARGER CARBURETORS RACE CARBURETORS MARINE CARBURETORS CARB SERVICE PARTS & ACCESSORIES FUEL INJECTION THROTTLE BODIES FUEL PUMPS INTAKE MANIFOLDS CYLINDER HEADS SYSTEMAX ENGINE DRESS-UP MERCHANDISING TECHNICAL INFORMATION

PART #	PAGE	PART #	PAGE	PART #	PAGE	PART #	PAGE
122-89	87	125-207	93	134-103S	74	162-517	139
122-90	87	125-208	93	134-104	74	162-518	71
122-91	87	125-209	93	134-104C	74	162-518	139
122-92	87	125-210	93	134-104S	74	162-523	71
122-93	87	125-211	93	134-105	74	162-524	71
122-94	87	125-212	93	134-105S	74	216-43	73
122-95	87	125-213	93	134-108	74	220-5	158
122-96	87	125-215	93	134-110	74	220-5	159
122-97	87	125-216	93	134-112	74	220-7	159
122-98	87	125-500	93	134-281	74	221-2	159
122-99	87	125-1005	93	134-281S	74	221-4	159
122-100	87	126-23-10	88	134-282	74	221-5	159
122-101	87	126-24-10	88	134-282S	74	241-80	160
122-102	87	126-25-10	88	135-1	65	241-81	160
122-103	87	126-26-10	88	135-2	94	241-201	160
122-104	87	126-27-10	88	135-3	94	241-209	160
122-105	87	126-28-10	88	135-4	94	241-213	160
122-106	87	126-29-10	88	135-5	66	241-215	160
122-107	87	126-30-10	88	135-6	94	241-218	160
122-108	87	126-31-10	88	135-7	66	300-14	145
122-109	87	126-32-10	88	135-9	66	300-25	142
122-110	87	126-33-10	88	135-10	66	300-72S	145
122-132	87	126-34-10	88	135-12	66	300-74S	145
122-136	87	126-35-10	88	135-14	66	300-75S	145
122-138	87	126-36-10	88	135-15	66	300-110	142
122-140	87	126-37-10	88	142-00	87	300-501-1	155
122-142	87	126-38-10	88	142-20	87	300-502	153
122-144	87	126-39-10	88	142-21	87	300-503-1	154
122-146	87	126-40-10	88	142-22	87	300-552-1	148
122-148	87	126-41-10	88	142-24	87	300-556	149
122-150	87	126-43-10	88	142-25	87	300-575	150
122-152	87	126-45-10	88	142-26	87	301-20	146
122-154	87	126-47-10	88	142-28	87	301-31	156
122-156	87	126-49-10	88	142-29	87	301-32	156
122-158	87	126-51-10	88	142-31	87	301-33	156
122-160	87	126-53-10	88	142-32	87	301-35	156
122-164	87	126-55-10	88	142-33	87	301-36	156
122-168	87	126-57-10	88	142-35	87	301-37	156
122-172	87	126-59-10	88	142-36	87	301-44	146
122-176	87	126-61-10	88	142-37	87	301-44	156
122-180	87	126-63-10	88	142-38	87	412-67	87
122-184	87	126-65-10	88	142-39	87	500-6S	117
122-188	87	126-67-10	88	142-40	87	500-13	117
122-192	87	126-69-10	88	142-41	87	500-16S	117
122-200	87	126-70-10	88	142-42	87	500-17S	117
122-5000	90	126-71-10	88	142-43	87	500-18S	117
125-10	93	126-72-10	88	142-46	87	500-19	117
125-25	93	126-73-10	88	142-52	87	500-20	117
125-35	93	126-74-10	88	142-55	87	502-3	120
125-45	93	126-75-10	88	142-59	87	502-4	120
125-50	93	126-76-10	88	142-62	87	502-5	120
125-55	93	126-77-10	88	142-64	87	502-6	120
125-65	93	126-78-10	88	142-70	87	502-7	120
125-75	93	134-8	90	142-73	87	502-9	120
125-85	93	134-9	90	142-76	87	502-20S	113
125-95	93	134-21	90	142-78	87	503-1	116
125-105	93	134-37	90	162-500	71	503-2	116
125-125	93	134-39	90	162-514	71	503-3	116
125-135	93	134-101	74	162-514	139	503-5	116
125-145	93	134-101S	74	162-515	71	503-6	116
125-155	93	134-102	74	162-515	139	508-1	114
125-165	93	134-102S	74	162-516	71	508-2	114
125-185	93	134-103	74	162-516	139	508-3	114
125-206	93	134-103C	74	162-517	71	508-5	115

PART #	PAGE	PART #	PAGE	PART #	PAGE	PART #	PAGE
508-6	115	534-43	117	534-153	100	703-51	84
508-7	115	534-44-1	117	534-156	100	703-53	84
508-8	115	534-45	117	534-157	100	703-55	84
508-9	115	534-46	116	534-158	100	703-58	84
508-10	114	534-47	117	534-160	116	703-59	84
508-11	115	534-48	117	534-161	116	703-60	84
508-12	114	534-49	108	534-162	115	703-66	84
508-14	115	534-50	93	534-163	115	712-327-11	133
508-15	115	534-50	116	534-165	115	712-454-11	133
508-16	115	534-51	93	534-166	115	712-454-13	133
508-17	109	534-51	116	534-167	115	712-801-1	134
508-18	109	534-54	114	534-168	115	712-802-1	134
508-19	114	534-55	114	534-169	116	712-815-1	134
508-19	115	534-56	117	534-170	116	890-160	108
512-1	114	534-72	114	534-171	117	950-19S	112
512-500-1	137	534-74	108	534-172	117	950-20S	112
512-500	137	534-77	108	534-173	117	950-21S	111
512-501	137	534-78	108	534-177	100	950-22S	111
512-502-1	137	534-78	118	534-181	108	950-23S	111
512-502	137	534-79	108	534-182	100	950-24S	111
512-503-5	137	534-79	118	534-183	104	950-51	112
512-504-5	136	534-80	108	534-184	104	950-52	112
512-505	136	534-80	118	534-185	108	950-53	112
512-506-1	137	534-82	108	534-186	108	950-100	100
512-506-2	137	534-83	108	534-187	117	950-101	100
512-507	137	534-84	108	534-188	104	950-103	100
512-509	137	534-85	108	534-190	108	950-104	100
522-40	115	534-100	116	534-191	100	950-105	100
522-43	115	534-102	108	534-195	100	950-106	100
522-54	115	534-103	108	534-196	100	950-109	100
522-80	115	534-104	108	534-197	105	950-110	100
522-81	115	534-112	108	534-200	105	950-113	100
522-1904	118	534-117	108	538-13	116	950-115	100
522-1906	118	534-120	100	538-13	116	1006	158
522-1908	118	534-120	108	538-23	108	1007WIN	158
522-2401	118	534-128	100	538-24	108	1008-844	66
522-2408	118	534-129	100	538-24	116	1009WIN	158
522-3001	118	534-129	109	543-1	116	1010WIN	158
522-3008	118	534-130	100	543-2	115	3009	158
522-3601	118	534-130	109	543-3	117	3010	159
522-3608	118	534-131	100	543-29	117	4000	68
522-4201	118	534-134	100	543-105	115	4000	146
522-4208	118	534-134	109	562-1	109	4021	68
522-5001	118	534-135	100	562-1	114	4021	146
522-5008	118	534-135	109	562-1	115	4022	68
522-6501	118	534-136	100	562-3	109	4022	146
522-6508	118	534-136	109	562-3	114	4023	146
522-7501	118	534-138	100	700-21	113	4025	68
522-7508	118	534-138	109	703-1	84	4025	146
522-9501	118	534-139	100	703-28	84	4027	68
522-9508	118	534-139	109	703-29	84	4027	146
534-2	116	534-140	100	703-30	84	4032	68
534-4	117	534-140	108	703-32	84	4032	146
534-10	108	534-142	100	703-33	84	7220	159
534-10	116	534-142	109	703-34	84	7221	159
534-23	117	534-143	100	703-35	84	7223	159
534-25-1	117	534-144	100	703-36	84	7460	67
534-26	108	534-144	108	703-39	84	7465	67
534-26	116	534-146	100	703-40	84	7466	67
534-27	114	534-147	100	703-41	84	7539	67
534-33	114	534-148	100	703-45	84	7540	109
534-37	114	534-149	100	703-47	84	7540	143
534-38	114	534-151	100	703-48	84	7540P	109
		534-152	100	703-50	84	7540P	143

HOW TO CHOOSE A CARB STREET CARBURETORS SUPERCHARGER CARBURETORS RACE CARBURETORS MARINE CARBURETORS CARB SERVICE PARTS & ACCESSORIES FUEL INJECTION THROTTLE BODIES FUEL PUMPS INTAKE MANIFOLDS CYLINDER HEADS SYSTEMAX ENGINE DRESS-UP MERCHANDISING TECHNICAL INFORMATION

INDEX

PART #	PAGE	PART #	PAGE	PART #	PAGE	PART #	PAGE
7542	143	101186ERL	77	82412001	106	92104101	103
7542P	143	101275ERL	77	91002101	103	92104111	103
8204	146	101276ERL	77	91003101	103	92105201	103
8206	146	101285ERL	77	91003111	103	92105211	103
9003	146	101286ERL	77	91004101	103	92106011	104
9006	67	102185ERL	77	91004111	103	92106201	103
9007	146	102186ERL	77	91005201	103	92106211	103
9008	146	102285ERL	77	91005211	103	92107011	104
9900-144	108	102286ERL	77	91006201	103	92107201	103
9900-145	108	103175ERL	77	91006211	103	92107211	103
9900-147	108	103176ERL	77	91007201	103	92204101	103
9900-149	108	105175ERL	77	91007211	103	92204111	103
9900-163	109	81002001	105	91102101	103	92205201	103
9900-171	109	81003001	105	91103101	103	92205211	103
9900-171	121	81004001	105	91103111	103	92206201	103
9900-172	108	81005001	105	91104101	103	92206211	103
9900-173	108	81006001	105	91104111	103	92207011	104
9901-101-1	109	81007001	105	91105201	103	92207201	103
9901-101-1	142	81009001	105	91105211	103	92207211	103
9901-107	109	81102001	106	91106201	103	92306011	104
9901-107	142	81103001	106	91106211	103	92306201	103
9901-201	109	81104001	106	91107201	103	92306211	103
9901-201	144	81105001	106	91107211	103	92307011	104
9901-202	109	81106001	106	91403201	101	92307201	103
9901-202	144	81107001	106	91403211	101	92307211	103
9901-203	109	81109001	106	91404201	101	92406201	103
9901-203	144	81403001	107	91404211	101	92406211	103
9901-204	109	81404001	107	91405201	101	92407011	104
9901-204	145	81405001	107	91405211	101	92407201	103
9901-205	109	81406001	107	91406201	101	92407211	103
9901-209	109	81503001	107	91406211	101	8R1899	80
9901-209	144	81504001	107	91500011	101	8R1906-1	79
9902-104	109	81505001	107	91503201	101	8R1907-1	80
9902-108	109	81506001	107	91503211	101	8R1909-1	80
9906-118	109	82004001	106	91504201	101	8R1910-1	79
9906-126	109	82005001	106	91504211	101	8R1911-1	79
9906-127	109	82006001	106	91505201	101	8R1912	79
9906-143	109	82007001	106	91505211	101	8R1915	80
9910-101	109	82009001	106	91506201	101	8R1916	80
9910-102	109	82010001	106	91506211	101	8R1919	79
9920-107	108	82104001	106	91603201	101	8R2224-1	79
9920-110	108	82105001	106	91603211	101	34R5113-3	90
9925-103	123	82106001	106	91604201	101	34R5972AQ	74
10000ERL	165	82107001	106	91604211	101	34R7800-3AMQ	74
10000FLT	165	82108001	106	91605201	101	34R9716-3	90
10001WND	165	82109001	106	91605211	101	34R9716-6	90
10003HOL	165	82110001	106	91606201	101	34R9716-12	90
10004HOL	166	82204001	106	91606211	101	34R9716-22	90
10005WND	166	82205001	106	91703201	101	34R9716-27	90
10145HKR	165	82206001	106	91703211	101	34R9716-32	90
10150HKR	166	82207001	106	91704201	101	34R9716-34	90
11000ERL	166	82209001	106	91704211	101	34R9716-54	90
19306	168	82210001	106	91705201	101	34R10918AQ	74
19326NOS	165	82306001	106	91705211	101	34R10935AQ	74
19327NOS	165	82307001	106	91706201	101		
19352NOS	166	82308001	106	91706211	101		
64280	158	82309001	106	92004101	103		
90520	85	82310001	106	92004111	103		
90633	158	82311001	106	92005201	103		
90633	159	82312001	106	92005211	103		
93156	159	82406001	106	92006201	103		
101175ERL	77	82407001	106	92006211	103		
101176ERL	77	82409001	106	92007201	103		
101185ERL	77	82410001	106	92007211	103		

#s

#1 in Fuel Systems banner 167

110 GPH Blue electric fuel pump 129

110 GPH Electric fuel pump 129

110 GPH Fuel pump 126,133

120 GPH Electric fuel pump 134

125 GPH Billet electric fuel pump 130

130 GPH Fuel pump 126,133

140 GPH Black electric fuel pump 129

140 GPH Electric fuel pump 129

150 GPH Billet electric fuel pump 130

170 GPH Fuel pump 126,127

170 GPH HP series 3 valve fuel pump 126,127

170 GPH HP series fuel pump 126,127

1-bbl TBI flange gasket 114

1-bbl TBI Renew kit 116

2 Barrel carburetors 10,11,22,
23,36,37,
48,49

200 GPH Ultra HP series 5 valve fuel pump 126,127,133

200 GPH Ultra HP series fuel pump 126,127,133

2-bbl TBI flange gasket 115

2-bbl TBI Renew kit 116

2-bbl TBI systems 112

2-bbl TBI systems 113

2x4 Carburetor linkage kit 146

2x4 Linkage kit 146

2x4 Tunnel ram carburetor linkage kit 146

2x4 Tunnel ram linkage kit 146

3 Valve fuel pump 126,127

30 Amp fuel pump relay kit 137

40 Amp relay 108

40 Amp relay 116

4-bbl TBI flange gasket 115

4-bbl TBI Renew kit 116

4-bbl TBI systems 110,111

4-bbl Throttle body linkage kit 116

5 Valve fuel pump 126,127

67 GPH Electric fuel pump 134

70 GPH Electric fuel pump 134

700R-4 Kickdown Throttle Arm 69

75th Anniversary Deuce T-shirt 164

80 GPH Fuel pump 126

97 GPH Electric fuel pump 128

97 GPH Red electric fuel pump 128

A

Accelerator pump arm 65

Accelerator pump assortment kit 65

Accelerator pump cams 65

Accelerator pump components 65,66

Accelerator pump cover 65

Accelerator pump diaphragms 65

Accelerator pump discharge nozzles 66

Accelerator pump tuning kit 66

Accelerator pump tuning kit 86

Adapter fitting 72

Adapters 67

Adjustable fuel pressure regulator 136

Adjustable needle & seat 91

Adjustable needle & seat hardware kit 91

Air bleed assortment kit 88

Air bleeds 88

Air charge sensor 116

Air cleaners 158

Air cleaner adapter 114

Air cleaner filter elements 159

Air cleaner gasket 78,108

Air cleaner spacers 159

Air foil kit 121

Air horn gasket 114,159

Air scoop filter elements 159

Air scoops 159

Air temperature sensor 108

Alcohol jets 87

Alcohol jet kit 89

American Icon T-shirt 164

Anniversary Deuce T-shirt 164

Auxiliary injector driver kit 100

B

Banners 167,168,169

Base gasket 78

Base gasket & studs 78

Base insulator 78

Base plate & gasket sealing kit 109

Base throttle body gasket 109

Belly Tanker Retro T-shirt 164

Billet electric fuel pump 130

Billet regulator bracket 135

Billet throttle bodies 121

Black electric fuel pump 129

Block-off plate 109

HOW TO CHOOSE A CARB
STREET CARBURETORS
SUPERCHARGER CARBURETORS
RACE CARBURETORS
MARINE CARBURETORS
CARB SERVICE PARTS & ACCESSORIES
FUEL INJECTION
THROTTLE BODIES
FUEL PUMPS
INTAKE MANIFOLDS
CYLINDER HEADS
SYSTEMAX
ENGINE DRESS-UP
MERCHANDISING
TECHNICAL INFORMATION
INDEX

Blower carburetors	34,35
Blue electric fuel pump	129
Blue non-stick fuel bowl gasket	79,80
Books & manuals	170
Boosters	95
Bottle Rocket T-shirt	164
Bowls	74
Bowl vents	75
Brackets & linkages	68,69,70
Brand decal sheet	166
Brand metal signs	165
Bypass style fuel pressure regulator	135

C

Calibration kit	86
Carb store	166
Carbureted electric fuel pumps	128
Carburetor adapters	67
Carburetor air scoops	159
Carburetor banner	167
Carburetor bypass fuel pressure regulator	135
Carburetor bypass style fuel pressure regulator	135
Carburetor fuel inlet brass filter	71
Carburetor fuel lines	76,77
Carburetor fuel pressure regulators	135
Carburetor hardware parts kit	86
Carburetor installation & tuning DVD	170
Carburetor numerical listing	170
Carburetor selection	6,7,8,9
Carburetor small gasket & plug kit	86
Carburetor small parts kit	86
Carburetors install kit	67
Center hung float	73
Choke control cable	70
Choke control cable	95
Choke control cable mounting hardware	70
Choke thermostat cap retainer kits	71
Choosing a carburetor	6,7,8,9
Chrome fuel bowl kit	75
Chrome round air cleaner	158
Circle track floats	73
Closed loop kit	114
Commander 950 2-bbl TBI systems	112
Commander 950 4-bbl TBI systems	110,111
Commander 950 cable	108
Commander 950 ECU	100,108
Commander 950 ECU injector wiring harness	109
Commander 950 engine kits	100

Commander 950 primary wiring harness	109
Commander 950 Pro software	98,99
Commander 950 software	100
Commander service parts	100
Competition carburetors	38,39,50, 51,54
Coolant temperature sensor	108,116
Cooling relay kit	100
Core Holley header card	162
Custom oval air cleaner	158
Custom valve cover	160
Cylinder head installation kit	156
Cylinder heads	148,149,150

D

Dashpot/Solenoid bracket	69
Decal sheet	166
Dentent cable bracket	70
Determining manifold height	146
Deuce T-shirt	164
Diaphragm housing cover	95
Direct replacement performance TBI	120
Discharge nozzles	66
Distributor	108
Distributor ring	114
Distributor wiring harness adapter	100
Dominator carburetors	44,45,52, 56,57,58
Double Pumper carburetors	18,19,25, 26,27,28,30
Dual feed fuel lines	76,77
Dual tank fuel pump kit	114

E

Earl's banner	168
Earl's retro T-shirt	163
ECU	114
EFI fuel pressure regulators	137
EFI fuel rails	118
EFI Intake manifold	142,144,145
EFI throttle bodies	122
EGR spacers	123
Electric choke conversion kits	70
Electric Fuel pressure gauge	85
Electric fuel pump	108,116,128
Electric fuel pump accessories	137
Electric fuel pump service kits	139,140

Electric in-line fuel pump 132
 Electric in-tank fuel pump 131
 Electro-Dyn heat sensor 71
 Electronic control unit 114
 Emulsion bleed kit 89
 Emulsion jets 87
 Exploded view of 4160 carburetor 64

F

Fast idle cam 71
 Fast idle cam plate 71
 Fast idle solenoid 117
 Fast Kit 81,82
 Fitting gaskets 72
 Fittings 109
 Flange gasket 115
 Float bowls 74
 Float hanger hardware kit 73
 Floats 73
 Flowtech exhaust banner 169
 Fre Flo air cleaner 158
 Fuel bowl conversion kit 74
 Fuel bowl screw gasket 79
 Fuel bowl screw gasket kit 75
 Fuel bowl service parts 75
 Fuel bowl sight plug & gasket kit 75
 Fuel bowl sight plug window kit 75
 Fuel bowl vent baffle/whistle 75
 Fuel bowl vent screen 75
 Fuel bowl vent tubes 75
 Fuel bowls 74
 Fuel filters 115
 Fuel filter element 109
 Fuel gauge pressure Fitting 72
 Fuel injector kits 118
 Fuel injection System 101
 Fuel injector bungs 108
 Fuel injector connector & terminals 108
 Fuel injector O-ring & retainers 108
 Fuel inlet fitting 72
 Fuel inlet plug 72
 Fuel line fitting 72
 Fuel lines 76,77
 Fuel lines & rails 108
 Fuel log 76,77
 Fuel management controller 136
 Fuel pressure regulators 135,136,137
 Fuel pressure regulator diaphragm 114

Fuel pump 126,127
 Fuel pump block off plate 116
 Fuel pump filter 114
 Fuel pumps banner 167
 Fuel rails 108
 Fuel transfer tube seals 75
 Fuel transfer tubes 75

H

Hall effect sensor wiring harness 100
 Head bolt sets 156
 Heat shield 79
 Heli-coil Inserts 93
 High-flow EFI throttle bodies 122
 History 2,3
 Hi-Tek air cleaner 158
 Holley Rebirth of an American Icon T-shirt 164
 Holley #1 in Fuel Systems banner 167
 Holley brand decal sheet 166
 Holley brand metal signs 165
 Holley brand neon wall clocks 166
 Holley carb store 166
 Holley carburetor banner 167
 Holley carburetor installation & tuning DVD 170
 Holley carburetor manual 170
 Holley carburetor numerical listing 170
 "Holley carburetors, manifolds & fuel injection manual" 170
 Holley family banner 167
 Holley fuel pumps banner 167
 Holley header card 162
 Holley model 4150 & 4160 carburetor handbook 170
 Holley retro T-shirt 163
 Holley Since 1903 hooded sweatshirt 165
 Holley Since 1903 T-shirt 165
 Holley Street Avenger header card 162
 Hood scoop plug 159
 Hooker Authorized Speed Shop banner 168
 Hooker retro T-shirt 163
 Hot Air choke conversion kits 70
 HP 2 barrel carburetors 36,37,48
 HP 4150 4 barrel carburetors 40,41,48,49,
 51,52,54,
 55,56
 HP 4500 4 barrel carburetors 44,45,52,56,
 57,58

HOW TO CHOOSE A CARB
 STREET CARBURETORS
 SUPERCHARGER CARBURETORS
 RACE CARBURETORS
 MARINE CARBURETORS
 CARB SERVICE PARTS & ACCESSORIES
 FUEL INJECTION
 THROTTLE BODIES
 FUEL PUMPS
 INTAKE MANIFOLDS
 CYLINDER HEADS
 SYSTEMS
 ENGINE DRESS-UP
 MERCHANDISING
 TECHNICAL INFORMATION
 INDEX

I	
IAC block-off plate	123
IAC	115
Idle air control motor	115
Idle air control motor gasket	115
Idle mixture screws	90
Idle mixture screw gasket	90
Illustrated parts & specs manual	170
Injection pod upgrade kit	116
Injectors	115
Injector O-ring kit	114
Injector O-ring kit	115
Injector pod	115
Injector retaining plate	115
Injector wiring harness	100
In-Line filters	71
In-line fuel pump	132
Installation & tuning DVD	170
Installation tool kit	93
Intake manifold installation kit	156
Intake manifold banner	169
Intake manifold choke kits	146
Intake manifold gaskets	146
Intake manifold installation kit	146
Intake manifold spacer kits	146
Intake manifolds	109,142
In-tank fuel pump	131
Interactive mapping software	117
Inverted flare fitting	72
J	
Jet assortment kit	89
Jet extensions	90
Jet holder kit	89
Jets	87
K	
Keith Dorton carburetors	36,37,48
Keith Dorton intake manifold	142
Knock sensor wiring kit	100
L	
Laptop computer cable	100
Lowrider carburetor	27
LS2 throttle bodies	123
M	
Magnetic pick-up wiring harness	100
Mainbody (for HP mainbody kit)	71
Main jet extensions	90
Main jet removal tool	93
Main jet tap	93
Main wiring harness	100
Manifolds	109,142
Manifold height	146
Manual choke conversion kits	71
Map sensor	108
MAP sensor	116
Map sensor bracket	109
Mapping software	117
Marine carb renew kit	84
Marine carburetors	59,60,61, 62,63
Marine Commander 950 4-bbl TBI systems	112
Marine fuel bowls	74
Marine mechanical fuel pump	133
Marine Pro Jection 2-bbl TBI systems	113
Marine TBI assemblies	117
Mechanical fuel pressure gauge	85
Mechanical fuel pump	126
Metal signs	165
Metering block gasket	79,80
Metering block plugs	90
Metering block service parts	90
Metering jets	87
Metering plate screws & gasket	80
Metering plate screws & gasket kits	80
Model 2300	10,11,22,23, 36,37,48,49
Model 4500 carburetors	44,45,52, 56,57,58
Morse throttle cable bracket	109
Multi point fuel injection	101,102, 103,104
Multi-point Fuel Injection Power pack kit	105,106
N	
NASCAR	4
Needle & seat assemblies	91
Neon wall clocks	166
New style O-ring transfer tube	79
NOS Bottle Rocket T-shirt	164
NOS Energy drink banner	168
NOS nitrous banner	168
Notched float hardware kit	73

O

OE muscle car carburetors 31
 OE replacement carburetors 32,33
 Off-Road carburetors 16,17,22,
 27,29,30
 Old style O-ring transfer tube 79
 O-ring transfer tube 79
 Oval air cleaner 158
 Oxygen sensor 108
 Oxygen sensor 116

P

Performance parts center plan-o-gram 162
 Phenolic spacers 67
 Power pack kit 105,106,107
 Power valve check ball kit 93
 Power valve plug & gasket 93
 Power valves 93
 Powershot filters 159
 Pro Jection 2-bbl TBI systems 113
 Pro Jection software 108
 Pump arm 65
 Pump cams 65
 Pump cover 65
 Punish the Pavement banner 169
 Pushrod set 156

Q

Quick change diaphragm housing cover 95
 Quick change fuel bowl plug gasket 78
 Quick change jet kit 75

R

Race 2 barrel carburetors 36,37,48
 Race MPFI system 104
 Rebirth of an American Icon T-shirt 164
 Red electric fuel pump 128
 Regulators 135,136,137
 Renew Kit 81,83
 Replacement carburetors 32,33
 Replacement electric choke caps 71
 Replacement fuel Bowl kits 74
 Replacement injector caps 116
 Retro T-shirts 163,164
 Rich/lean indicator 116
 Rich/lean indicator 93

Rich/lean indicator w/ oxygen sensor 93
 Round air cleaner 158

S

Secondary adjusting lever 68
 Secondary connecting rods 68
 Secondary metering plate gasket 80
 Selecting a carburetor 6,7,8,9
 Side hung float 73
 Sight plug window kit 75
 Since 1903 hooded sweatshirt 165
 Since 1903 T-shirt 165
 Single-stage power valves 93
 Spacers 67
 Spark fitting 68
 Spread flange to square bore adapters 67
 Square flange to spread bore adapters 67
 Squirters 66
 Standard fitting 72
 Standard main jets 87
 Stealth Ram 101
 Stealth Ram intake manifold 143
 Stealth Ram multi point fuel injection 101
 Stealth Ram multi point power pack kits 107
 Steel inlet needles 91
 Street Avenger carburetors 14,15,23,26,
 29,30,31
 Street Avenger header card 162
 Street Dominator intake manifolds 145
 Street HP carburetors 20,21,26,
 28,29
 Strip Dominator intake manifolds 142
 Supercharger carburetors 34,35
 Sure Flo II air cleaner 158
 SysteMAX engine kits 152,153,1
 54,155

T

T-shirts 163,164,165
 TBI adapter 114
 TBI assembly 117
 TBI fuel filter 109
 TBI wiring harness 100
 TH-350 transmission kickdown cable manifold bracket 69
 TH-700R4 transmission bracket 109
 TH-700R4 transmission kickdown cable carb bracket 69
 Throttle solenoid 69
 Throttle bodies 120

HOW TO CHOOSE A CARB
 STREET CARBURETORS
 SUPERCHARGER CARBURETORS
 RACE CARBURETORS
 MARINE CARBURETORS
 CARB SERVICE PARTS & ACCESSORIES
 FUEL INJECTION
 THROTTLE BODIES
 FUEL PUMPS
 INTAKE MANIFOLDS
 CYLINDER HEADS
 SYSTEMAX
 ENGINE DRESS-UP
 MERCHANDISING
 TECHNICAL INFORMATION
 INDEX

HOW TO CHOOSE A CARB	Throttle body assemblies	109
STREET CARBURETORS	Throttle body gasket	79
SUPERCARGER CARBURETORS	Throttle boy service parts	123
RACE CARBURETORS	Throttle cable bracket	69,70
MARINE CARBURETORS	Throttle cable clip	68
CARB SERVICE PARTS & ACCESSORIES	Throttle lever extension	69,116
FUEL INJECTION	Throttle lever stud bushing	68
THROTTLE BODIES	Throttle plate kits	68
FUEL PUMPS	Throttle plate service kits	123
INTAKE MANIFOLDS	Throttle position sensor	108,116,117
CYLINDER HEADS	Throttle return springs	69
SYSTEMAX	Throttle shaft conversion kits	68
ENGINE DRESS-UP	Throttle shaft service kits	68
MERCHANDISING	Throttle solenoid bracket	69
TECHNICAL INFORMATION	Throttle studs	68
INDEX	Titanium inlet needles	91
	Traditional carburetors	12
	Transfer tubes	75
	Transmission cable bracket	114
	Transmission kickdown Lever Extensions	69
	Transmission kickdown spring & bracket	69
	Transmission kickdown throttle linkage	69
	Trick Kit	81,82
	Truck Avenger carburetors	16,17,22, 27,29,30
	Tuning kit	86
	Tuning/calibration kit	86
	Two barrel carburetors	10,11,22,23, 36,37,48,49
	Two-stage power valves	93
	U	
	Ultra HP 4150 carburetors	42,43,50, 52,55
	Ultra HP 4500 carburetors	46,47,57,58
	Umbrella check valve	66
	Universal 4-bbl billet throttle bodies	121
	Universal carb install kit	67,86
	Universal dashpot	70
	Universal solenoid solenoid & dashpot bracket locknut	70
	Universal throttle solenoid	70

V

V-bowls	74,75
Vacuum boost gauge	85
Vacuum cap assortment	86
Vacuum gauge	85
Vacuum passage gasket	79
Vacuum secondary diaphragm spring kit	95
Vacuum secondary diaphragms	94
Valve cover accessories	160
Valve cover service parts	160
Valve covers	160
Vent baffle	75
Vent screen	75
vent tubes	75
Venturii booster kits	95
Viton inlet needles	91
VoluMAX filters & components	138
VoluMax fuel Filters	71,139
VoluMAX regulator service parts	140

W

Wall clocks	166
Weiand Belly Tanker Retro T-shirt	164
Weiand Intake Manifold banner	169
Weiand retro T-shirt	163
Wide Band O2	104,105
Wide Band O2 upgrade hardware	104
Wiring harness	117
Wiring harness adapter	117
Wiring harness closed loop	117
Wiring terminals package	117

Holley and other manufacturers have developed a program whereby all emission-sensitive products can be identified by placing color-coded labels on product packaging and listing corresponding numeric codes next to each part number. The color codes and explanations are as follows:



The product accompanying this document has been granted a California Air Resources Board (CARB) exemption, an "OE" number, or is a direct or consolidated replacement part. It is 50-state legal, per the manufacturer's application guide.



The manufacturer of the product accompanying this document represents that it has not been found, nor is believed to be, unlawful for use under provisions of the Clean Air Act, per the manufacturer's application guide. This product is not legal for sale or use in the State of California (or in states which have adopted California emission standards) except on pre-emission-controlled motor vehicles/motor vehicle engines (pre-1966 model year).



The product accompanying this document is legal only for off-highway use (except in California or states that have adopted California emission standards), racing use or for use on pre-emission-controlled motor vehicles/motor vehicle engines (pre-1966 domestic vehicles certified to California standards, pre-1968 domestic vehicles certified to federal standards and all pre-1968 foreign vehicles), per the manufacturer's application guide.



HOLLEY STREET AVENGER™, TRUCK AVENGER™ & LOW-RIDER AVENGER™ LIMITED LIFETIME WARRANTY

Holley Performance Products warrants its Holley Street Avenger™/ Truck Avenger™ Carburetor to be free from defects in material and workmanship for the life of the product on parts and one year on repair labor. After a period of one year, Holley will charge standard rates for repair labor. For any Holley Street Avenger™ Carburetor used in any type racing or off-road use will only be covered by a one (1) year limited warranty on parts and labor. For any Holley Truck Avenger™ Carburetor used in any type of racing will only be covered by a one (1) year warranty on parts and labor. Warranty performance will be initiated by returning the defective product to HOLLEY PERFORMANCE PRODUCTS with the original, dated purchase receipt. Purchaser is to call toll free the Holley Factory Service number at 1-866-GOHOLLEY to receive details and shipping instructions.

Holley Performance Products does not warrant products which have been (a) modified or altered outside factory specifications, (b) subjected to conditions such as abuse, misuse, neglect, accident, improper installation or adjustment, contaminants, water or corrosion, gum or varnish, use of improper or poor quality fuel or fuel additives, fire from a backfire, and faulty repair or (c) in other than those automotive applications recommended in a current Holley catalog. Holley shall not be responsible for (a) actual or alleged installation or removal labor, inbound shipment costs or other incidental charges or (b) actual or alleged incidental or consequential damages incurred by the use of a Holley Street Avenger Carburetor. Further, there are no warranties, which extend beyond those stated here.

This warranty is extended to the original consumer purchaser and has as duration the lifetime from date of original purchase by such consumer. THIS WARRANTY IS EXPRESSLY IN LIEU OF ALL OTHER WARRANTIES EXPRESS OR IMPLIED INCLUDING, BUT NOT LIMITED TO, THE WARRANTIES OF MERCHANTABILITY AND FITNESS FOR A PARTICULAR PURPOSE AND ALL OTHER OBLIGATIONS OR LIABILITIES ON OUR PART. WE NEITHER ASSUME, NOR AUTHORIZE ANY OTHER PERSON TO ASSUME FOR US, ANY OTHER LIABILITY IN CONNECTION WITH THE SALE OF THIS STREET AVENGER™/ TRUCK AVENGER™ CARBURETOR. WE MAKE NO WARRANTY WHATSOEVER IN RESPECT TO ACCESSORIES OR PARTS NOT SUPPLIED BY US. AS USED IN THIS WARRANTY, "PURCHASER" SHALL BE DEEMED TO MEAN ONLY THAT PERSON FOR WHOM THE STREET AVENGER™/ TRUCK AVENGER™ CARBURETOR WAS ORIGINALLY PURCHASED.

Final warranty determination will be the decision of Holley Performance Products.

Some states do not allow the exclusion or limitation of incidental or consequential damages, or limitations on how long an implied warranty lasts, so the above limitations or exclusions may not apply to you.

This warranty gives you specific legal rights, and you may also have other rights that vary from state to state. This warranty shall apply only within the boundaries of the continental United States.

W A R R A N T Y



HOLLEY PERFORMANCE PRODUCTS LIMITED WARRANTY NO OTHER WARRANTIES APPLY

Holley® Performance Products warrants its new performance products to be free from defects in material and workmanship for a period of 90 days from date of purchase.

Holley® Performance Products Limited Warranty specifically does not apply to products which have been (a) modified or altered in any way; (b) subjected to adverse conditions such as misuse, neglect, accident, improper installation or adjustment, dirt or other contaminants, water, corrosion or faulty repair; or (c) used in other than those applications recommended by Holley® Performance Products. Holley® Performance Products also does not warrant, and disclaims all liability for products used in racing activities and/or applications other than those specifically recommended in the current Holley® catalog.

This Limited Warranty is extended to the original consumer only. This Limited Warranty is not assignable or otherwise transferable. There are no warranties which extend beyond those stated herein. Holley® Performance Products offers no other warranties, express or implied beyond this Limited Warranty.

In the event of an alleged defect in material or workmanship, Holley® Performance Products' responsibility is strictly limited to repair or replace the defective product. Holley® has no other obligation express or implied. Final warranty determination will be in the sole discretion of Holley® Performance Products. Holley® shall not be responsible for: (a) actual or alleged labor, transportation or other incidental charges; or (b) actual or alleged consequential or other damages incurred by use of any product of Holley® Performance Products.

To initiate the warranty process:

Return the alleged defective product to the original place of purchase with dated purchase receipt and completed applicable warranty claim tag. Warranty claims will be rejected if the consumer cannot establish date of purchase. Unless the product was purchased directly from Holley® Performance Products, do not send directly to Holley® Performance Products. Holley® Performance Products assumes no responsibility for unauthorized products sent directly to Holley® Performance Products.

This Limited Warranty sets forth specific legal rights. The consumer may have other rights as a result of variations in state laws or provincial laws. This Limited Warranty supersedes all prior warranty statements.

Avenger™ series carburetor warranty is outlined on page 224

HOLLEY

Performance Catalog

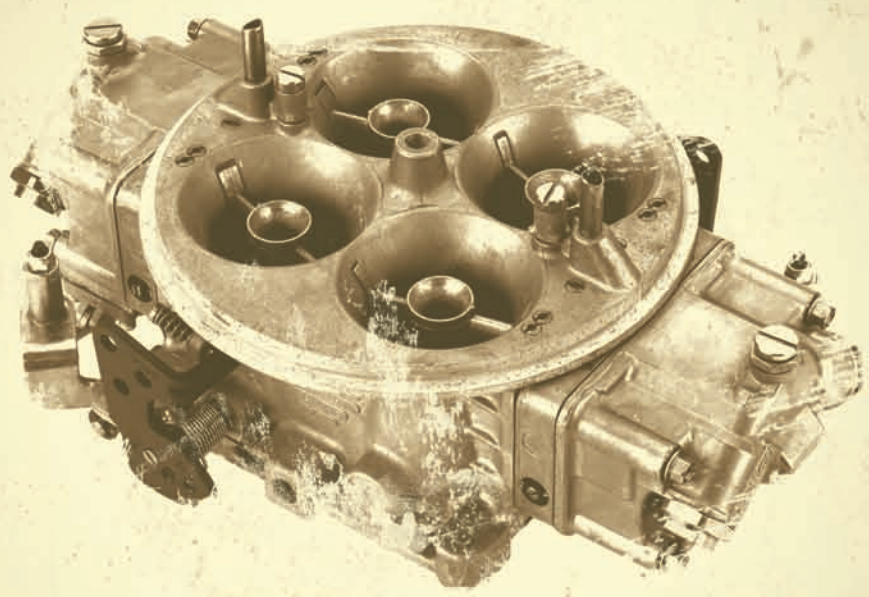

**Holley Carbs Power Every
NASCAR® SPRINT® Cup Series Team!**

NASCAR® and NASCAR Performance® are registered trademarks of the National Association of Stock Car Auto Racing, Inc.



DEALER LINE: 1-800-HOLLEY • TECH LINE: 270-781-9741 • WEBSITE: WWW.HOLLEY.COM
1801 RUSSELLVILLE ROAD, P.O. BOX 10360 • BOWLING GREEN, KY 42102-7360

P/N L30924 • © HOLLEY PERFORMANCE PRODUCTS INC 2008 • PRINTED IN USA